

MODEL NUMBER DAD05079

Analog Detector

FEATURES

- 20-2000 MHz
- 25 dB Dynamic Range
- Low Output Resistance
- Low DC Power Consumption
- Pin for Pin Replacement to HP/Avantek PPD-2001 with Improved Performance

TD

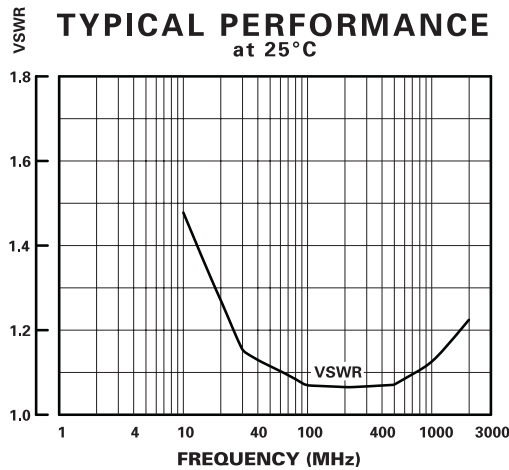
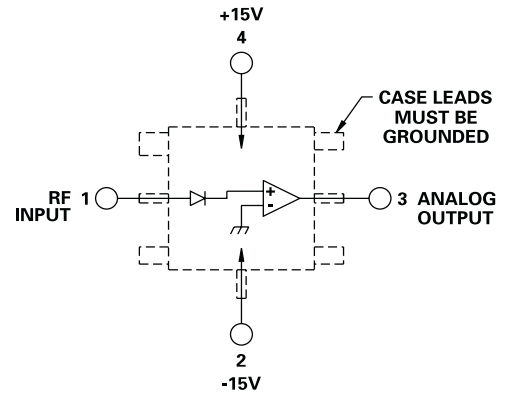
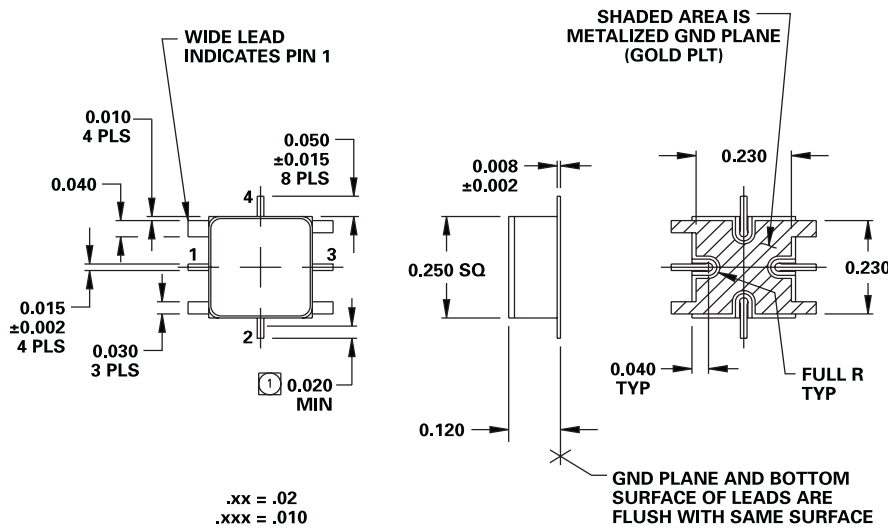

GUARANTEED PERFORMANCE

Parameter	Min	Typ	Max	Units	Conditions
Operating Frequency	20		2000	MHz	
Dynamic Range	-10		+10	dBm	
Input VSWR		1.3/1	1.8/1		
Analog Output	0.8	0.9		V	P = 0 dBm
		0.19		V	P = -10 dBm
Input Flatness		±0.3	±1.0	dB	0 to -10 dBm
Temperature Stability		±0.4	±1.0	dB	0 to -10 dBm
Tangential Sensitivity		-38		dBm	
Output Resistance		1		OHMS	
Output Offset	-5	0	+5	mV	No Input Power
Output Offset Drift		±5		mV	Over Temperature
RF to Video Isolation		50		dB	
Rise Time		2		µSec	
DC Current		1.4	2	mA	+15V
		1.5	2	mA	-15V
Input Power			+20	dBm	No Damage
Operating Temperature	-55	+25	+125	°C	TA