

T-41-41

P SERIES

PLASTIC ENCAPSULATED PHOTOCELLS

- Resistance Tolerance @ 2 ft-c
± 33-1/3%
- 5 Photoconductive Materials
- Temperature Range: - 25° C to
+ 75° C
- Maximum Power:
5P — 250mw, 7P — 125mw,
9P — 50mw

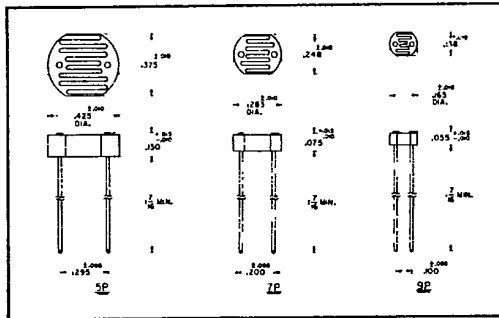

TYPE	Sensitive Material	Peak Spectral Response (Angstroms)	Resistance @ 2ft-c (Ohms)	Min. Dark Resistance 5 sec. After 2 ft-c	Maximum Voltage Rating (Peak A.C.)	Measurement Voltage
CL5P4L	Type 4 CdSe	6900	.45K	120K	170V	1.35V
CL7P4L			1.0K	268K	170V	4.0V
CL9P4L			2.0K	520K	100V	8.0V
CL5P5	Type 5 CdS	5500	9.0K	450K	250V	12V
CL5P5M			6.0K	400K	250V	10V
CL9P5			166K	11 Meg	250V	35V
CL5P5L			1.5K	75K	170V	10V
CL7P5L			3.3K	165K	170V	10V
CL9P5L			10K	670K	100V	10V
CL7P5HL	Type 5H CdS	5500	28K	14 Meg	170V	10V
CL7P7HL	Type 7H CdS	6200	10K	6.7 Meg	170V	8.0V
CL9P7HL			24K	16 Meg	100V	16V
CL9P7HLL			4.5K	3.0 Meg	70V	4.0V
CL7P9L			28K	18.7 Meg	170V	10V
CL9P9L	Type 9 CdS	5500	100K	67 Meg	100V	10V
CL9P9LL			15K	10 Meg	70V	10V

MEASUREMENT DATA • All measurements at 2854°K • Cells light adapted 16 hrs. at 30 ft-c prior to test
• Measurement voltage is D.C. applied voltage for measuring resistance • All readings made at 25°C ambient.