

BLF052SYC-6V-P SUPER BRIGHT YELLOW

Features

- BUILT-IN CURRENT LIMITING RESISTOR FOR DIRECT APPLICATION OF DIFFERENT ACROSS CURRENT.
- LONG LIFE.
- LOW CURRENT, POWER SAVINGS.
- LOW MAINTENANCE.
- DIFFERENT COLOR AVAILABLE.
- SOLID STATE, HIGH VIBRATION RESISTANT.
- 6V INTERNAL RESISTOR.

Description

The Super Bright Yellow source color devices are made with DH InGaAlP on GaAs substrate Light Emitting Diode.

Package Dimensions

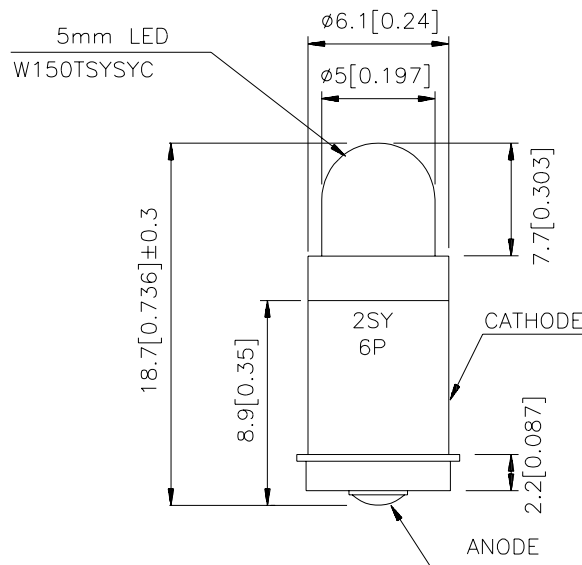

Notes:

1. All dimensions are in millimeters (inches).
2. Tolerance is $\pm 0.25 (0.01")$ unless otherwise noted.
3. Specifications are subject to change without notice.

Selection Guide

Part No.	Dice	Lens Type	Iv (mcd) V=6V		Viewing Angle
			Min.	Typ.	2θ1/2
BLF052SYC-6V-P	SUPER BRIGHT YELLOW(InGaAlP)	WATER CLEAR	280	400	45°

Note:

1. θ1/2 is the angle from optical centerline where the luminous intensity is 1/2 the optical centerline value.

Electrical / Optical Characteristics at T_A=25°C

Symbol	Parameter	Device	Typ.	Max.	Units	Test Conditions
λ _{peak}	Peak Wavelength	Super Bright Yellow	590		nm	V _F =6V
λ _D	Dominate Wavelength	Super Bright Yellow	588		nm	V _F =6V
Δλ _{1/2}	Spectral Line Half-width	Super Bright Yellow	28		nm	V _F =6V
I _F	Forward Current	Super Bright Yellow	25		mA	V _F =6V
I _R	Reverse Current	Super Bright Yellow		10	uA	V _R =5V

Absolute Maximum Ratings at T_A=25°C

Parameter	Super Bright Yellow	Units
Power dissipation	180	mW
Forward Voltage	7	V
Reverse Voltage	5	V
Operating Temperature	-40 °C To + 70 °C	
Storage Temperature	-40 °C To + 85 °C	

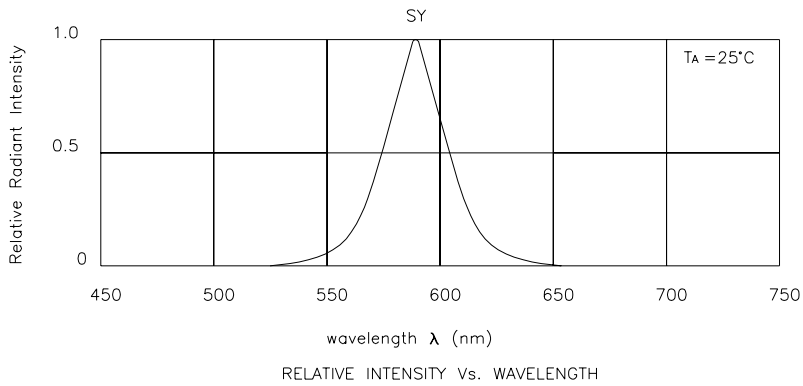

Super Bright Yellow **BLF052SYC-6V-P**

