

Low voltage transmission circuits with dialer interface
1. GENERAL DESCRIPTION

The BL1062A1 is integrated circuits that perform all speech and line interface functions required in fully electronic telephone sets. It performs electronic switching between dialling and speech. The ICs operate at line voltage down to 1.6 V DC (with reduced performance) to facilitate the use of more telephone sets connected in parallel. BL1062A1 improves the EMC performance in-circuit that can enhance the telephone sets' EMC.

2. FEATURES

- Low DC line voltage; operates down to 1.6 V (excluding polarity guard)
- Voltage regulator with adjustable static resistance
- Provides a supply for external circuits
- Symmetrical high-impedance inputs ($64\text{ K}\Omega$) for dynamic, magnetic or piezoelectric microphones
- Asymmetrical high-impedance input ($32\text{ K}\Omega$) for electret microphones
- DTMF signal input with confidence tone
- Mute input for pulse or DTMF dialling, active LOW (MUTE)
- Receiving amplifier for dynamic, magnetic or piezoelectric earpieces
- Large gain setting ranges on microphone and earpiece amplifiers
- Line loss compensation (line current dependent) for microphone and earpiece amplifiers
- Gain control curve adaptable to exchange supply
- DC line voltage adjustment facility
- Enhanced EMC performance

3. BLOCK DIAGRAM

Fig. 1 Block Diagram

4. Pin Configurations, Definitions

SYMBOL	PIN	DESCRIPTION
LN	1	positive line terminal
GAS1	2	gain adjustment; transmitting amplifier
GAS2	3	gain adjustment; transmitting amplifier
QR	4	non-inverting output; receiving amplifier
GAR	5	gain adjustment; receiving amplifier
MIX-	6	Inverting microphone input
MIC+	7	non-inverting microphone input
NC	8	NC
VEE	9	Negative line terminal
IR	10	Receiving amplifier input
DTMF	11	dual-tone multi-frequency input
MUTE	12	mute input (see note 1)
Vcc	13	positive supply decoupling
REG	14	voltage regulator decoupling
AGC	15	automatic gain control input
SLPE	16	slope (DC resistance) adjustment

5. Function Description
Supplies VCC , LN, SLPE, REG

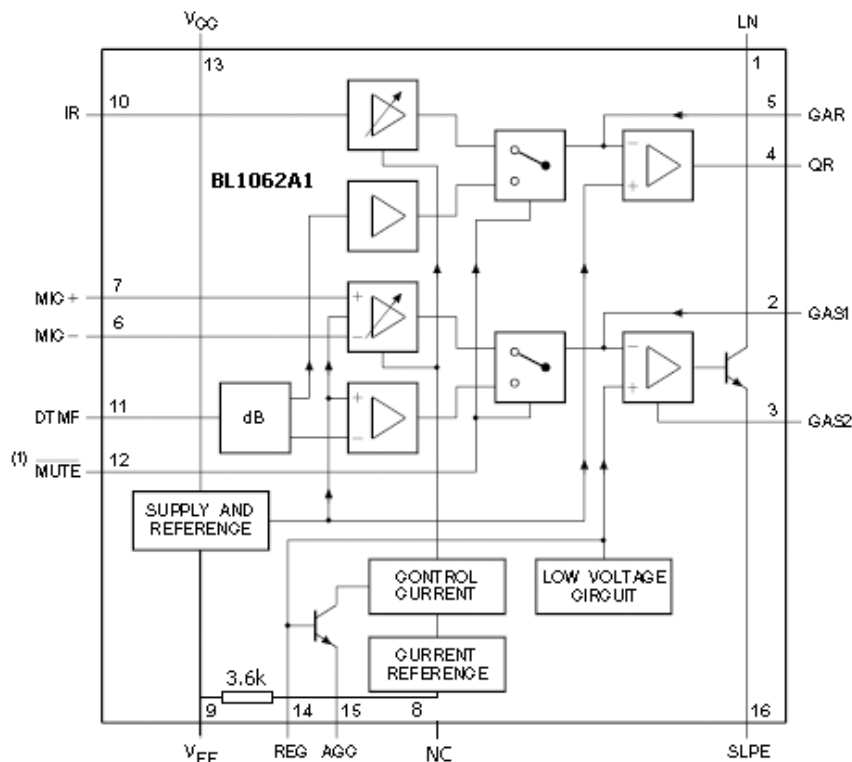
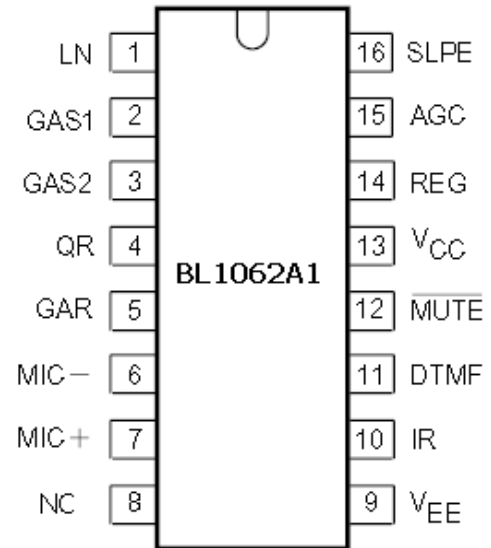
Power for the IC and its peripheral circuits is usually obtained from the telephone line. The supply voltage is derived from the line via a dropping resistor and regulated by the IC. The supply voltage vcc may also be used to supply external circuits e.g. dialling and control circuits. Decoupling of the supply voltage is performed by a capacitor between Vcc and VEE . The internal voltage regulator is decoupled by a capacitor between REG and VEE . The DC current flowing into the set is determined by the exchange supply voltage V_{exch} , the feeding bridge resistance R_{exch} and the DC resistance of the telephone line R_{line} .

At line currents below 9 mA the internal reference voltage is automatically adjusted to a lower value (typically 1.6 V at 1 mA). This means that more sets can be operated in parallel with DC line voltages (excluding the polarity guard) down to an absolute minimum voltage of 1.6 V. At line currents below 9 mA the circuit has limited sending and receiving levels. The internal reference voltage can be adjusted by means of an external resistor (R_{VA}). This resistor when connected between LN and REG will decrease the internal reference voltage and when connected between REG and SLPE will increase the internal reference voltage.

Microphone inputs MIC+ and MIC- and gain pins GAS1 and GAS2

The circuit has symmetrical microphone inputs. Its input impedance is 64 k Ω (2 x 32 k Ω) and its voltage gain is typically 52 dB (when $R_7 = 68$ k Ω , see Figures 2 and 3). Dynamic, magnetic, piezoelectric or electret (with built-in FET source followers) can be used. The gain of the microphone amplifier can be adjusted between 44 dB and 52 dB to suit the sensitivity of the transducer in use. The gain is proportional to the value of R_7 , which is connected between GAS1 and GAS2.

Input MUTE

When MUTE is LOW or open-circuit, the DTMF input is enabled and the microphone and receiving amplifier inputs are inhibited. The reverse is true when MUTE is HIGH. MUTE switching causes only negligible clicking on the line and earpiece output. If the number of parallel sets in use causes a drop in line current to below 6 mA the DTMF amplifier becomes active independent to the DC level applied to the MUTE input.

Dual-tone multi-frequency input DTMF

When the DTMF input is enabled dialling tones may be sent on to the line. The voltage gain from DTMF to LN is typically 25.5 dB (when R7 = 68 k Ω) and varies with R7 in the same way as the microphone gain. The signalling tones can be heard in the earpiece at a low level (confidence tone).

Receiving amplifier IR, QR and GAR

The receiving amplifier has one input (IR) and a non-inverting output (QR). The IR to QR gain is typically 31 dB (when R4 = 100 k Ω). It can be adjusted between 20 and 31 dB to match the sensitivity of the transducer in use. The gain is set with the value of R4, which is connected between GAR and QR. The overall receive gain, between LN and QR, is calculated by subtracting the anti-sidetone network attenuation (32 dB) from the amplifier gain. The output voltage of the receiving amplifier is specified for continuous-wave drive. The maximum output voltage will be higher under speech conditions where the peak to RMS ratio is higher.

Automatic Gain Control input AGC

Automatic line loss compensation is achieved by connecting a resistor (R6) between AGC and VEE. The automatic gain control varies the gain of the microphone amplifier and the receiving amplifier in accordance with the DC line current. The control range is 5.8 dB which corresponds to a line length of 5 km for a 0.5 mm diameter twisted-pair copper cable with a DC resistance of 176 Ω /km and average attenuation of 1.2 dB/km). Resistor R6 should be chosen in accordance with the exchange supply voltage and its feeding bridge resistance. The ratio of start and stop currents of the AGC curve is independent of the value of R6. If no automatic line-loss compensation is required the AGC pin may be left open-circuit. The amplifiers, in this condition, will give their maximum specified gain.

Enhanced EMC performance

The input pins BL1062A1 is added RC filters to improve the EMC performance, so the telephone sets which used BL1062A1 are easily to handle the EMC design.

LIMITING VALUES

SYMBOL	PARAMETER	CONDITIONS	MIN.	MAX.	UNIT
V _{LN}	positive continuous line voltage		–	12	V
V _{LN(R)}	repetitive line voltage during switch-on or line interruption		–	13.2	V
V _{LN(RM)}	repetitive peak line voltage for a 1 ms pulse per 5 s	R9 = 20 Ω ; R10 = 13 Ω ; see Fig.6	–	28	V
I _{line}	line current	R9 = 20 Ω	–	140	mA
P _{tot}	total power dissipation	R9 = 20 Ω	–	600	mW
T _{amb}	operating ambient temperature		–25	+75	°C
T _{stg}	storage temperature		–40	+125	°C

6. CHARACTERISTICS
 $I_{line} = 11$ to 140 mA; $V_{EE} = 0$ V; $f = 800$ Hz; $T_{amb} = 25$ °C; unless otherwise specified.

SYMBOL	PARAMETER	CONDITIONS	MIN.	TYP.	MAX.	UNIT
V _{LN}	voltage drop over circuit between LN and VEE	MIC inputs open-circuit $I_{line} = 1$ mA $I_{line} = 4$ mA $I_{line} = 15$ mA $I_{line} = 100$ mA		1.6 1.9 4.0 5.7	4.25 6.5	V V
V _{LN}	Voltage drop over circuit between LN and VEE	$I_{line} = 15$ mA; $R_{VA}(LN \text{ to } REG) = 68K\Omega$ $R_{VA}(LN \text{ to } SLPE) = 39K\Omega$		3.5 4.5		
I _{CC}	supply current	$V_{CC} = 2.8$ V	–	0.9	1.35	mA
V _{CC}	supply voltage available for peripheral circuitry	$I_{line} = 15$ mA; MUTE = LOW $I_p = 1.2$ mA MUTE = LOW $I_p = 0$ mA	2.2 2.5	2.7 3.4	4.5 3.8	V V V V
Z _i	Input impedance between MIC- and MIC+	Between MIC- and MIC+		64		K Ω
CMRR	Common mode rejection ratio			82		dB
G _v MIC	voltage gain MIC+ or MIC- to LN	$I_{line} = 15$ mA; $R_7 = 68$ k Ω $I_{line} = 100$ mA; $R_7 = 68$ k Ω	50.5 44.0	52.0 45.5	54.5 47.0	dB dB
Δ G _v f	Gain variation with frequency reference to 800Hz	F=300 and 3400 Hz		± 0.2		dB
Δ G _v T	Gain variation with temperature reference to 25°C	Without R ₆ ; $I_{line} = 50$ mA; $T_{amb} = -25$ and $+75$ °C		± 0.2		dB
Z _i	Input impedance of DTMT			20.7		K Ω
G _v DTMF	voltage gain from DTMF to LN	$I_{line} = 15$ mA; $R_7 = 68$ k Ω	24.0	25.5	27.0	dB
Δ G _v f	Gain variation with frequency reference to 800Hz	F=300 and 3400 Hz		± 0.2		dB
Δ G _v T	Gain variation with temperature reference to 25°C	Without R ₆ ; $I_{line} = 50$ mA; $T_{amb} = -25$ and $+75$ °C		± 0.2		dB
V _{LN(rms)}	output voltage (RMS value)	THD = 10% $I_{line} = 15$ mA	1.7	2.3	–	V
Z _i	Input impedance of receiving amplifier			21		K Ω
G _v	voltage gain from IR to QR	$I_{line} = 15$ mA; $R_L = 300$ Ω $I_{line} = 100$ mA; $R_L = 300$ Ω	29.5 24.5	31 26	32.5 27.5	dB dB
Δ G _v f	Gain variation with frequency reference to 800Hz	F=300 and 3400 Hz		± 0.2		dB
Δ G _v T	Gain variation with temperature reference to 25°C	Without R ₆ ; $I_{line} = 50$ mA; $T_{amb} = -25$ and $+75$ °C		± 0.2		dB
V _{o(rms)}	output voltage (RMS value)	THD = 2%; sine wave drive; $R_4 = 100$ k Ω ; $I_{line} = 15$ mA; $I_p = 0$ mA $R_L = 150$ Ω $R_L = 450$ Ω	0.22 0.3	0.33 0.48	– –	V V

$V_{o(rms)}$	output voltage (RMS value)	THD = 10%; $R_4 = 100\text{ k}\Omega$; $I_{line} = 15\text{ mA}$; $R_L = 150\ \Omega$		15		V
ΔG_V	MIC- or MIC+ to LN	MUTE=Low		70		dB
ΔG_V	Voltage gain from DTMT to QR	$R_4=100\text{k}\Omega$; $R_L=300\Omega$ MUTE=Low		-17		dB
ΔG_V	Controlling the gain from IR to QR and the gain from MIC+,MIC- to LN gain control range	$R_6=110\text{k}\Omega$ (between AGC and VEE) $I_{line}=70\text{mA}$		-5.8		dB
I_{lineH}	Highest line current for maximum gain			23		mA
I_{lineL}	Lowest line current for maximum gain			61		mA

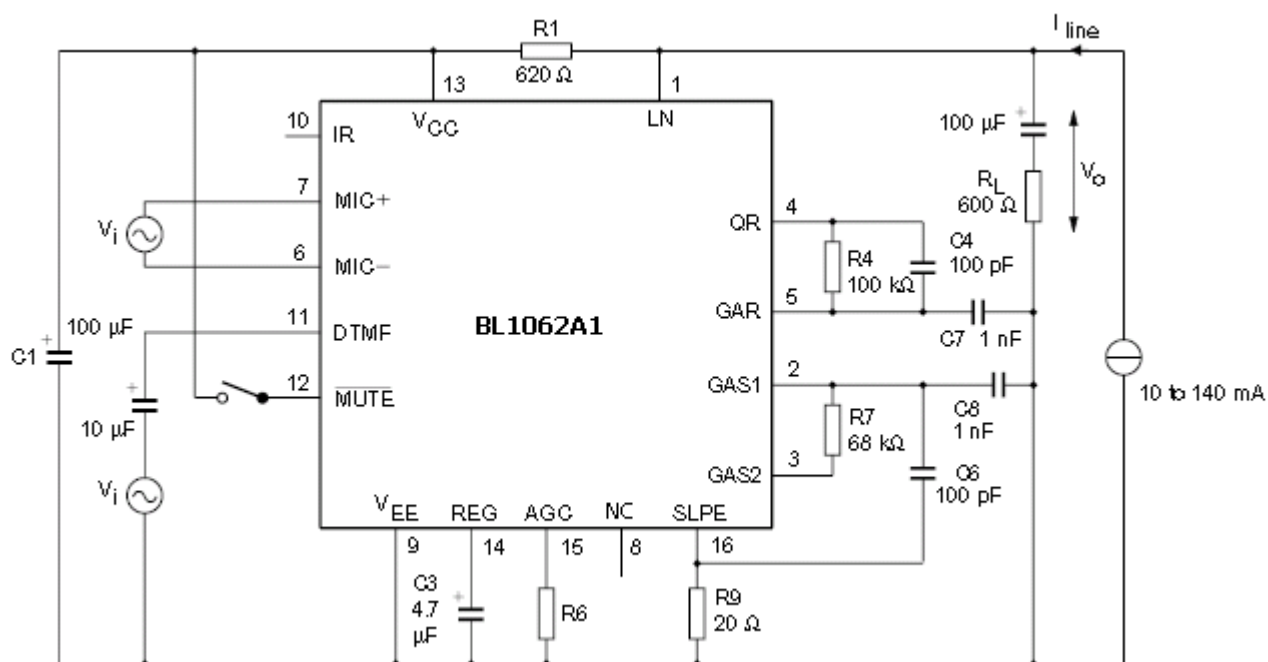

Fig2 Test circuit for defining BL1062A1 voltage gain of MIC+, MIC- and DTMF inputs

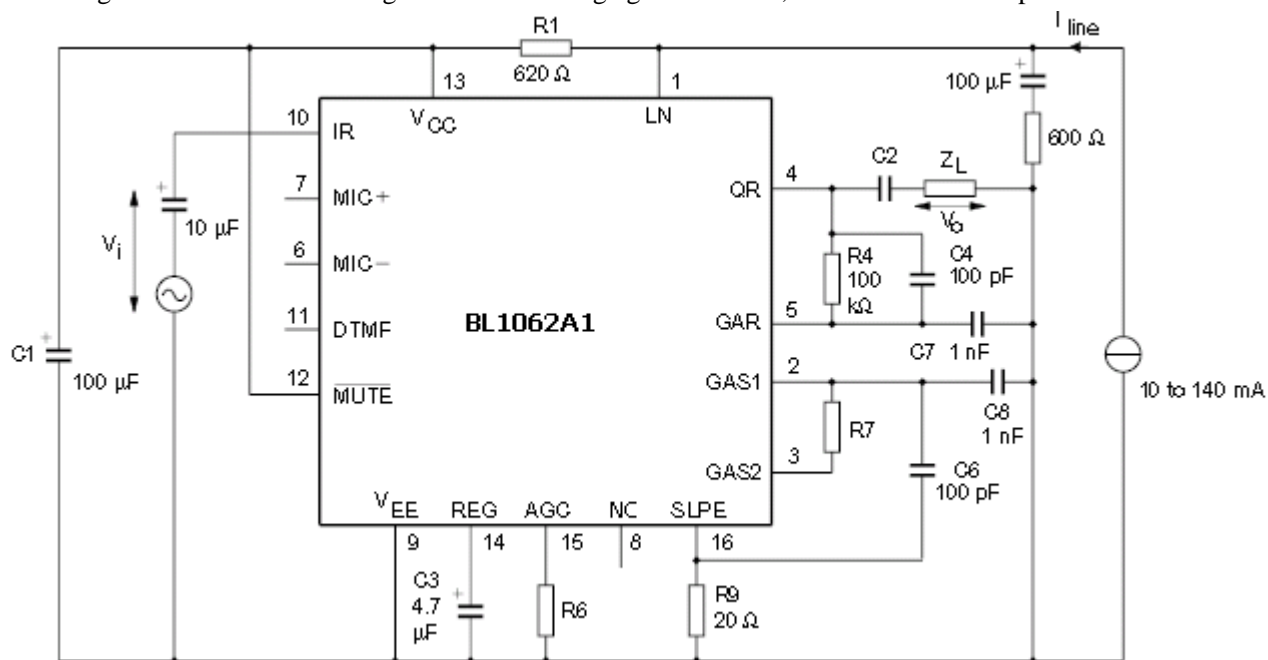

Fig3 Test circuit for defining BL1062A1 voltage gain of receiving amplifier

7. APPLICATION CIRCUITS

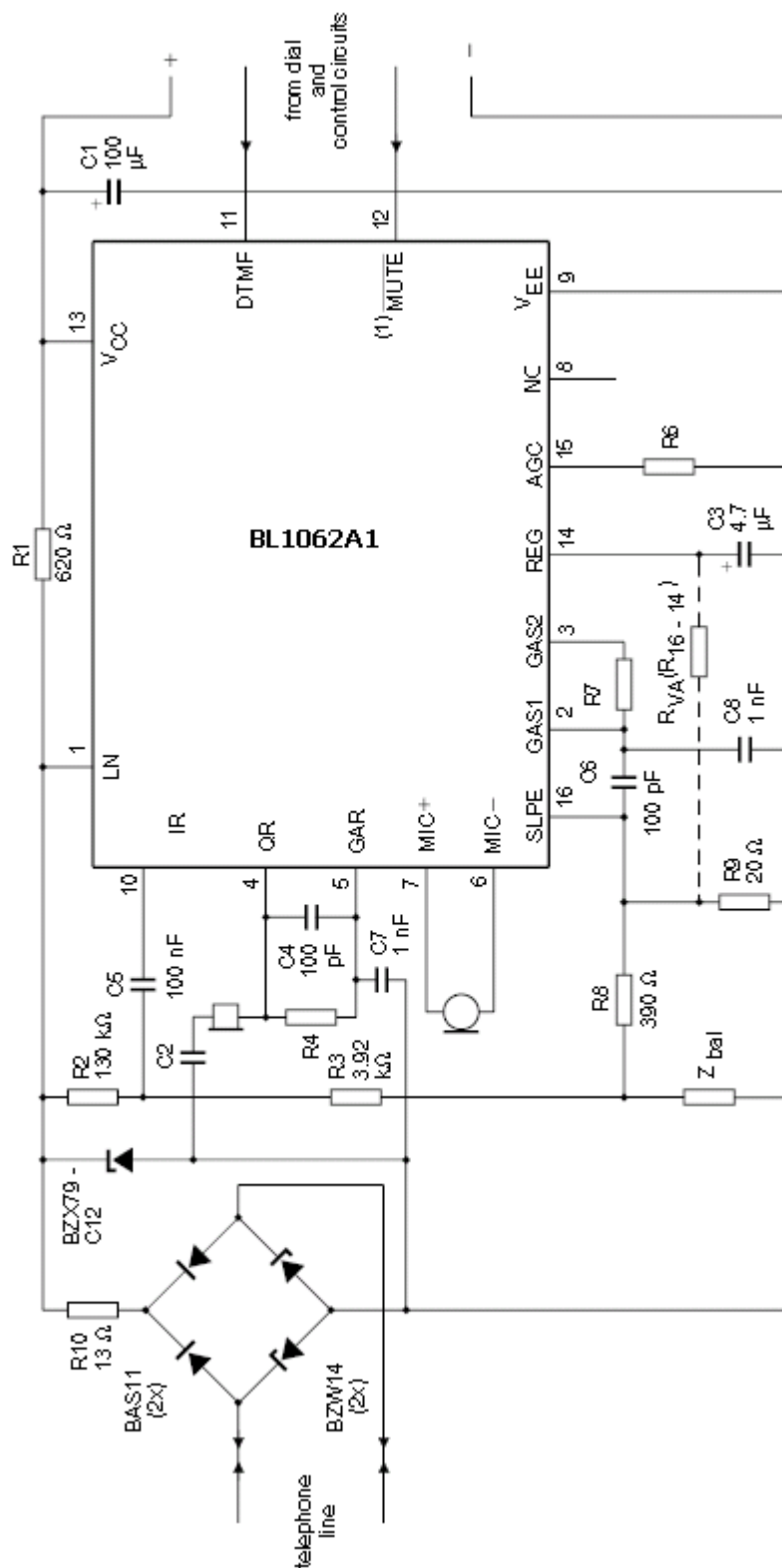

Fig4 Typical application of BL1062A1