

1.0 General Description

The AMIS-710404-A8 (PI404MC-A8) is a contact image sensor (CIS) module. It is a long contact image chip, which uses MOS image sensor technology for high-speed performance and high sensitivity. The AMIS-710404-A8 is suitable for scanning A8 size (57mm) documents with 15.7 dots per millimeter (dpm) resolution. Applications include document scanning, mark readers, gaming and office automation equipment.

2.0 Key Features

- Light source, lens and sensor are integrated into a single module
- 15.7dpm resolution, 57mm scanning length
- 1.8msec/line scanning speed @ 500kHz clock rate
- Wide dynamic range
- Analog output
- Yellow-Green light source 570nm
- Compact size \cong 13mm x 19mm x 70mm
- Low power
- Light weight

3.0 Functional Description

The AMIS-710404-A8 imaging array consists of 7 sensors, which are cascaded to provide 896 photo-detectors with their associated multiplex switches and a digital shift register, which controls its sequential readout. Mounted in the module is a one-to-one graded indexed micro lens array, which focuses the scanned documents to image onto its sensing plane. The on-board amplifier processes the video signal to produce a sequential stream of video at the video output pin of the AMIS-710404-A8 module.

Illumination is accomplished by means of an integrated LED light source. All components are housed in a small plastic housing which has a cover glass, which acts as the focal point for the object being scanned and protects the imaging array, micro lens assembly and LED light source from dust. I/O to the module is the 10-pin connector located on one end of the module (see Figure 4). The cross section of the AMIS-710404-A8 is shown in Figure 1 and the block diagram in Figure 2.

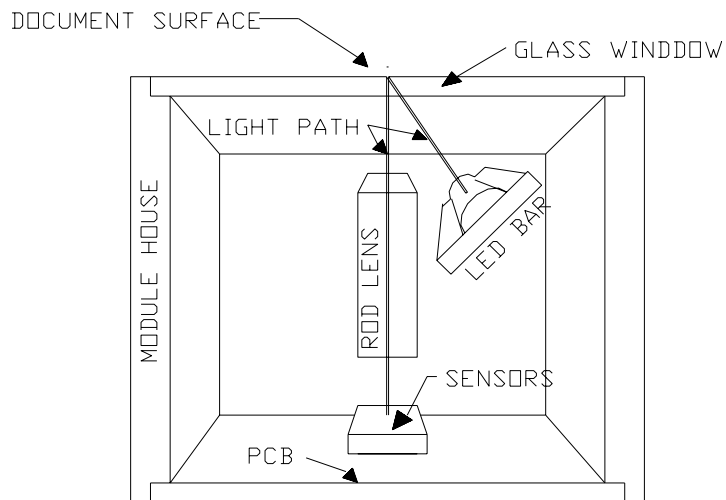

INSIDE PICTORIAL OF THE MODULE

Figure 1: AMIS-710404-A8 Cross Section

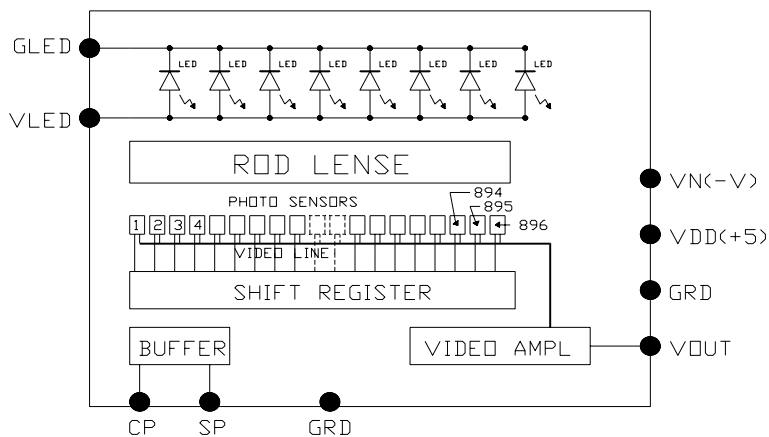

Figure 2: AMIS-710404-A8 Module Block Diagram (See Table 1)

Table 1: Pin Configuration

Pin Number	Symbol	Names and Functions
1	Vout	Analog video output
2	Gnd	Ground; 0V
3	Vdd (+5V)	Positive power supply
4	Vn (-5V to -12V)	Negative power supply
5	Gnd	Ground; 0V
6	SP	Shift register start pulse
7	Gnd	Ground; 0V
8	CP	Sampling clock pulse
9	GLED	Ground for the light source; 0V
10	VLED	Supply for the light source

4.0 Absolute Maximum Rating

Table 2: Absolute Maximum Rating

Parameter	Symbols	Maximum Rating	Units
Power supply voltage	Vdd	6	V
	Idd	40	ma
	Vn	-15	V
	In	10	ma
	VLED	5.5V	V
	ILED	300	ma
Input clock pulse (high level)	Vih	Vdd - 0.5V	V
Input clock pulse (low level)	Vil	-0.5	V

5.0 Environmental Specifications

Table 3: Operating and Storage Environment

Parameter	Symbols	Maximum Rating	Units
Operating temperature ⁽¹⁾	Top	0 to 50	°C
Operating humidity ⁽¹⁾	Hop	10 to 90	%
Storage temperature ⁽¹⁾	Tstg	-20 to +75	°C
Storage humidity ⁽¹⁾	Hstg	10 to 90	%

Note:

- (1) These are standard specifications for the CIS modules.

6.0 Electro-Optical Characteristics at 25°C

Table 4: Electro-Optical Characteristics at 25°C

Parameter	Symbol	Parameter	Units	Note
Number of photo detectors		896	Elements	
Pixel-to-pixel spacing		63.5	µm	
Line scanning rate	Tint ⁽¹⁾	2.92	msec	@ 307kHz clock frequency
Clock frequency ⁽²⁾	f	307	kHz	
Bright output voltage ⁽³⁾	Video output	2.0+/- 0.2	Volt	
Bright output non-uniformity ⁽⁴⁾	Up	+/-30	%	
Dark non-uniformity ⁽⁵⁾	Ud	<200	mV	
Dark output voltage ⁽⁶⁾	Dark level (DL)	-200<DL<200	mV	
Modulation transfer function ⁽⁷⁾	MTF	>45	%	

- Notes:**
- (1) Tint: line scanning rate or integration time. Tint is determined by the interval between two start pulses (SP).
 - (2) f: main clock frequency also equals the video sampling frequency.
 - (3) Video output level is controlled with an adjustment as well as integration time.
 - (4) $U_p = \{[V_p(\max) - V_p(\min)] / V_p(\max)\} \times 100\%$
Where VP(max) = maximum peak pixel and VP(min) = minimum pixel.
 - (5) $U_d = V_{d\max} - V_{d\min}$
Vdmin is the minimum output voltage with LED off.
Vdmax is maximum output voltage with LED off.
 - (6) This level is measured from the reset level, which is located between the pixels, during the pixel reset duration. The reset level is at ground, 0V. It can be adjusted with the offset potentiometer located on the module.
 - (7) $MTF = [(V_p(n) - V_p(n+1)) / (V_p(n) + V_p(n+1))] \times 100 [\%]$
Vp(n): nth maximum output pixel from a 4.0 lp/mm target.
Vp(n+1): (n+1)th minimum output pixel from a 4.0 lp/mm target.
 - (8) lp / mm: line pair per mm

7.0 Recommended Operating Conditions at 25°C

Table 5: Recommended Operating Conditions (25°C)

Item	Symbol	Min.	Typ.	Max.	Units
Power supply	Vdd	4.5	5.0	5.5	V
	Vn.	-12	-5	-4.0	V
	Idd		30		ma
	In		8		ma
	ILED		250	300	ma
	VLED		+5		V
Input voltage at digital high	Vih	Vdd -1.0	Vdd -.5	Vdd	V
Input voltage at digital low	Vil	0		0.6	V
Clock frequency	f	0.	0.30	1.0	MHz
Clock pulse high duty cycle			25		%
Clock pulse high duration			0.8		us
Integration time	Tint		3.0		ms
Operating temperature ⁽¹⁾	Top		25	50	°C

- Note:**
- (1) See the note under Table 3.

8.0 Switching Characteristics (25°C)

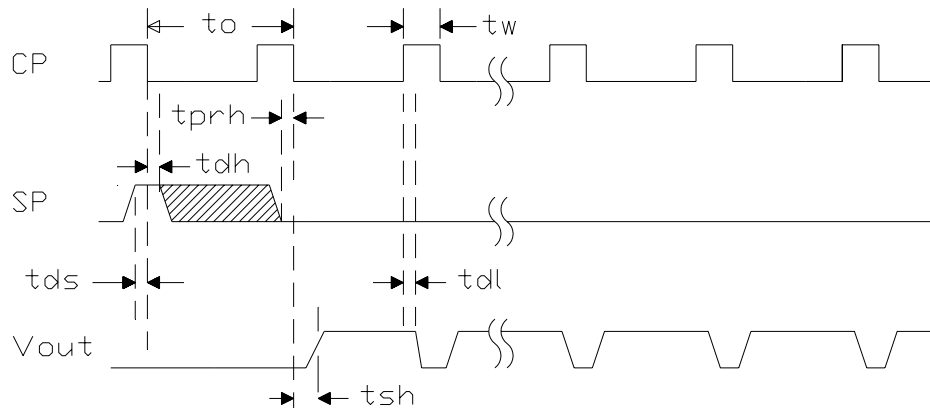

MODULE TIMING DIAGRAM

Figure 3: Module Timing Diagram

The switching characteristics (25°C) for the I/O clocks are shown in Figure 3. For the timing symbol definitions see Table 6.

Table 6: Timing Symbol's Definition and Timing Values

Item	Symbol	Min.	Typ.	Max.	Units
Clock cycle time	t_o	1.0		4.0	μ s
Clock pulse width	t_w	250			ns
Clock duty cycle		25		75	%
Prohibit crossing time of SP ⁽¹⁾	t_{prh}	0			ns
Data setup time	t_{ds}	20			ns
Data hold time	t_{dh}	0			ns
Signal delay time	t_{dl}	20			ns
Signal settling time	t_{sh}	100			ns

Note:

(1) "Prohibit crossing of start pulse" is to indicate that the start pulse should not be active high between any two consecutive high going clock pulses or two consecutive low going clock pulses (see Figure 3). Only one high going clock under the active high start pulse initiates the internal shift register, and it must not be active over two high going clocks. All low going clock pulses will not initiate the shift register but to ensure that the start pulse will not be actively high during two consecutive high going clocks, the circuit should be designed to keep the start pulse active only for one low going clock cycle.

9.0 Mechanical Structure of the Module

An isometric overview drawing of the AMIS-710404-A8 module's housing is shown in Figure 4. These modules are supplied with plastic end caps. However, for a more compact installation the end caps can be removed, provided that the modules are kept in the dark with no external light leakage allowed inside the housing.

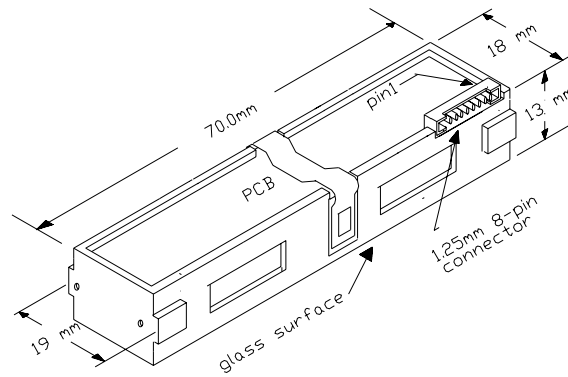

Figure 4: AMIS-710404-A8 Module Housing

Although the standard module comes with connector pins extruding to the sides as shown, a straight pinned socket can be installed into the PCB with its pins extruding directly up from its mount PCB. However, this must be requested upon ordering of the modules, otherwise the standard configuration will be shipped.

For module design-in, a detailed drawing is available upon request.

10.0 Company or Product Inquiries

For more information about AMI Semiconductor, our technology and our product, visit our Web site at: <http://www.amis.com>

North America

Tel: +1.208.233.4690
Fax: +1.208.234.6795

Europe

Tel: +32 (0) 55.33.22.11
Fax: +32 (0) 55.31.81.12

Production Technical Data - The information contained in this document applies to a product in production. AMI Semiconductor and its subsidiaries ("AMIS") have made every effort to ensure that the information is accurate and reliable. However, the characteristics and specifications of the product are subject to change without notice and the information is provided "AS IS" without warranty of any kind (express or implied). Customers are advised to obtain the latest version of relevant information to verify that data being relied on is the most current and complete. AMIS reserves the right to discontinue production and change specifications and prices at any time and without notice. Products sold by AMIS are covered by the warranty and patent indemnification provisions appearing in its Terms of Sale only. AMIS makes no other warranty, express or implied, and disclaims the warranties of noninfringement, merchantability, or fitness for a particular purpose. AMI Semiconductor's products are intended for use in ordinary commercial applications. These products are not designed, authorized, or warranted to be suitable for use in life-support systems or other critical applications where malfunction may cause personal injury. Inclusion of AMIS products in such applications is understood to be fully at the customer's risk. Applications requiring extended temperature range, operation in unusual environmental conditions, or high reliability, such as military or medical life-support, are specifically not recommended without additional processing by AMIS for such applications. Copyright © 2006 AMI Semiconductor, Inc.