

REVISIONS				
ECO	REV	DESCRIPTION	DATE	APPROVED
687	A	CHANGED MATERIAL	7-25-97	RBD
730	B	CHG: NOTE 2.1 , WAS: L = 88 UH.	12-18-97	RBD
1023	C	CHG: NOTES 2.1, & 3.3 PER ECO	05-15-00	RBD
---	C1	ADD PERMACORE 87-9040-26	11/10/00	RBD

PROPRIETARY DATA:
 This document and information contained
 may not be reproduced, used or disclosed
 without prior written permission of WESTCOR
 a division of VICOR Corporation.

NOTES:UNLESS OTHERWISE SPECIFIED

1. MATERIALS: UL RECOGNIZED 94V-2
 FLAMMABILITY RATING CLASS B (130°C)
 REQUIRED.

1.1 CORE: TOROID, $\mu = 5000$

MAGNETICS: ZJ-43806-TC OR
 PERMACOR: 87-9040-26

1.2 WIRE: U.L. RECOGNIZED 130°C RATING
 MAGNEI

1.3 OUTER WRAP: 3M #11 OR #69
 OR PERMASIL #213 OR 286

2. SPECIFICATIONS:

- 2.1 L = 82.5 μ H MIN/COIL (1 KHZ, <1Vrms)
- 2.2 DCR = 0.6 mOHMS MAX/COIL
- 2.3 POWER LOSS = 4.3 W MAX @ 60A/COIL
- 2.4 HI-POT TEST COIL TO COIL, 250VDC
 TO INSURE INTEGRITY OF WINDING
 INSULATION COVERING HAS NOT BEEN
 BREACHED.

3. CONSTRUCTION:

3.1 WIND COILS EVENLY SPACED (NOTE
 POLARITY)

3.2 REMOVE INSULATION AND TIN LEADS APPROX
 FLUSH WITH THE COIL, AS SHOWN (I.E. COIL
 MUST REST FLAT ON PCB). LEADS MUST BE
 TANGENT TO THE CORE.

3.3 WRAP INDUCTOR WITH TAPE, (PER NOTE 1.3).
 MARK PART NUMBER AND REVISION IN (BLACK) APPROX.
 WHERE SHOWN, USING A PERMANENT MARKING METHOD.

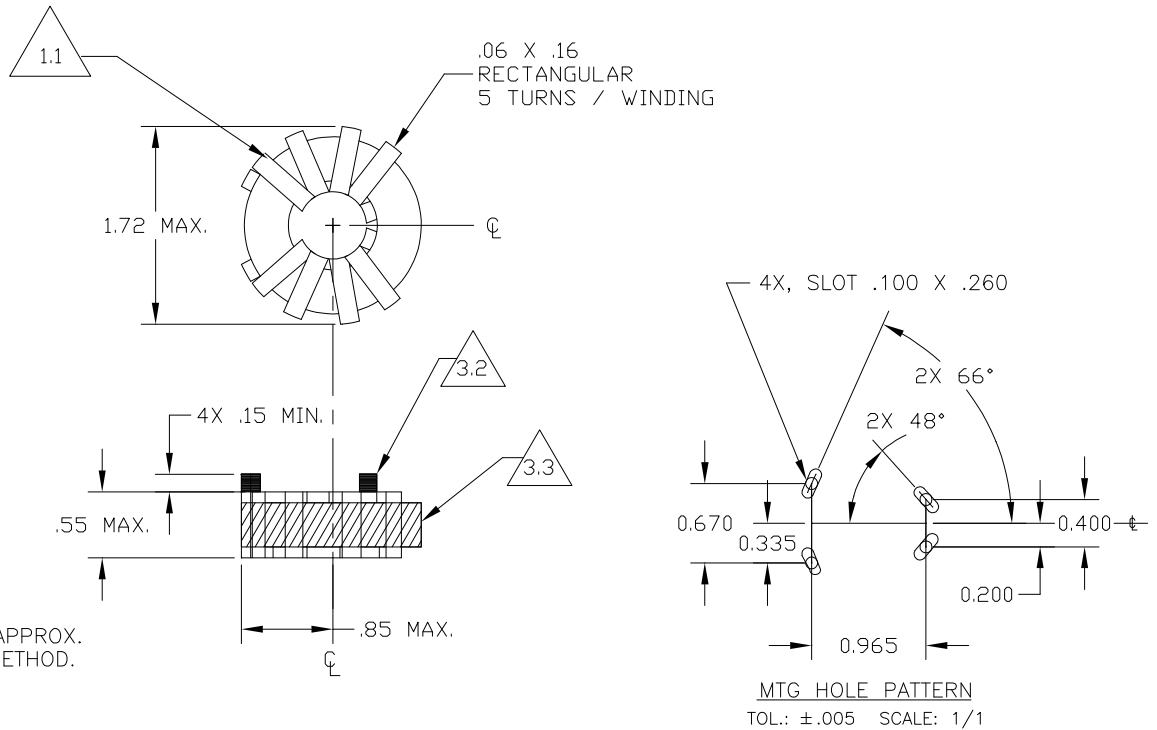

		UNLESS OTHERWISE SPECIFIED DIMENSIONS ARE IN INCHES TOLERANCES ARE: FRACTIONS DECIMALS ANGLES ± --- .XX ± .05 ± 3'	CONTRACT NO. ---		WESTCOR a division of VICOR Corp.
		MATERIAL SEE NOTES	APPROVALS	DATE	
---	SEE MIS	FINISH ---	DRAWN M.E. ITURRALDE	12/3/96	IND COMMON MODE 110 μ H 60A
NEXT ASSY	USED ON		CHECKED L.KING	7/25/97	
APPLICATION		DO NOT SCALE DRAWING	APPROVED R.B.DRABING	7/25/97	SIZE B
			DESIGNED R.CABALLERO	12/03/96	CAGE CODE ---
					DWG NO. 36-00029-07
					REV C1
					SCALE NTS
					FILENAME36-00029-07.DWG
					SHEET 1 OF 1