

DATE : 2005. 01. 17.

SPECIFICATION

PRODUCT : REMOCON MODULE

MODEL : 346HF12A

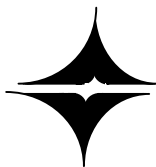

OPTO ELECTRONICS CO., LTD.

1066-12 YOUNJANG-RI, JINAN-UP, JINAN-GUN

JEON-BUK, KOREA.

TEL : (063) 433-4566~8

FAX : (063) 433-4569

E mail : poweroec@kornet.net

A P P R O V A L S H E E T

2005. 01. 17.

T I T L E	REMOCON - MODULE	PARTS NAME	346HF12A
		CODE NO.	
Application	UL, CSA, JMI, VDE, BSI, SEMKO, DEMKO, ()		

1. Application

This approval sheet applies to the review and approval for the remocon module 346HF12A of color TV, etc...

2. General Description

2-1. The supplier who wants to change the components, structure, material, location, and process needs to be reapproved.

2-2. Quality guarantee is depended on Component Quality Guarantee Contract.

3. Dimension and Expression

3-1. Dimension and expression

Refer to the drawing.

3-2. Expression (MARKING SPEC')

Refer to the drawing.

4. Material list

NO.	Parts Name	Specification	Quantity	Source	Vendor	Remark
1	I . C	T2526N338	1	ATMEL	MYUNG SUNG	
2	PHOTO DIODE	SD-202	1	AUK		
3	LEAD FRAME	LF-3A	1	HYUNDAI G.G		
4	MOLD CUP	RM-H1		DONG SUNG		
5	CASTING RESIN	DC-5280		DAEJOO F.C		
6	CASTING RESIN	DH-5280		DAEJOO F.C		

A P P R O V A L S H E E T

2005. 01. 17.

T I T L E	REMOCON - MODULE	PARTS NAME	346HF12A
		CODE NO.	
Application	UL, CSA, JMI, VDE, BSI, SEMKO, DEMKO, ()		

NO.	Parts Name	Specification	Quantity	Source	Vendor	Remark
7	CASE	RC-H5(P)	1	KEO SUNG		

* Enter the name of the second manufacture corporation, do not enter the name of the first manufacture corporation when there is no another corporation.

5. Absolute Maximum Ratings

Characteristics	Value	Remarks
Supply Voltage	6.0 VRMS	
Supply Current	- mARMS	
Operating Temperature	-20℃ ~ +70℃	
Storage Temperature	-40℃ ~ +85℃	

6. Electro-Optical Characteristics

(It is tested on condition at 25℃±2℃, humid 60~70%.)

Characteristics	Symbol	Specification			Unit	Condition
		MIN	TYP	MAX		
Supply Voltage	Vcc	2.7		5.5	Vrms	
Consumption current	Icc		1.2	2.0	mArms	No input signal

A P P R O V A L S H E E T

2005. 01. 17.

T I T L E	REMOCON - MODULE	PARTS NAME	346HF12A
		CODE NO.	
Application	UL, CSA, JMI, VDE, BSI, SEMKO, DEMKO, ()		

Characteristics	SYMBOL	Specification				CONDITION	
		MIN	TYPE	MAX			
High Level Output Voltage	VH	Vcc-0.2	Vcc	-	Vo-P	* 1	
Low Level Output Voltage	VL	-	0.2	0.4	Vo-P	* 1	
High Level Pulse Width	TWH	400	-	800	μ s	* 2	
Low Level Pulse Width	TWL	400	-	800	μ s	* 2	
BPF Center Frequency	Fo	-	38	-	kHz		
Peak Wave Length	P	-	940	-	nm		
Arrival Distance	L	2.7V	-	15	-	m	* 3
		3.0V	-	20	-	m	
		4.0V	-	25	-	m	
		5.0V	-	25	-	m	
		5.5V	-	25	-	m	
Operation Angle	2 m	85	-	-	°	* 4	
	5 m	75	-	-	°		

* 1 : Depart 30cm from a receiving lense.

* 2 : The standard transmitter shall be specified of the burst wave form in the FIG 1 adjusted to Vout 50mVp-p upon Po measuring circuit FIG 2.

FIG 1) Output Waveform

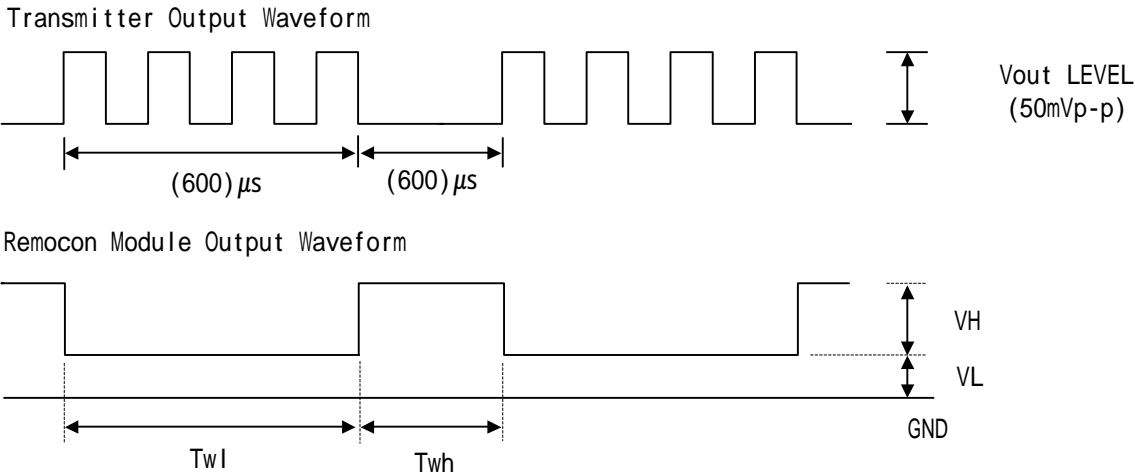

2005. 01. 17.

T I T L E	REMOCON - MODULE	PARTS NAME	346HF12A
		CODE NO.	
Application	UL, CSA, JMI, VDE, BSI, SEMKO, DEMKO, ()		

FIG 2) standard transmitter and measuring method

- The standard transmitter which applies a IR-LED CL-1L5R is TM32.
 ...(Projection of IR-LED is - 0.1 ~ + 0.2mm)
- The standard transmitter supplies to the DC 3V not battery but power supply.

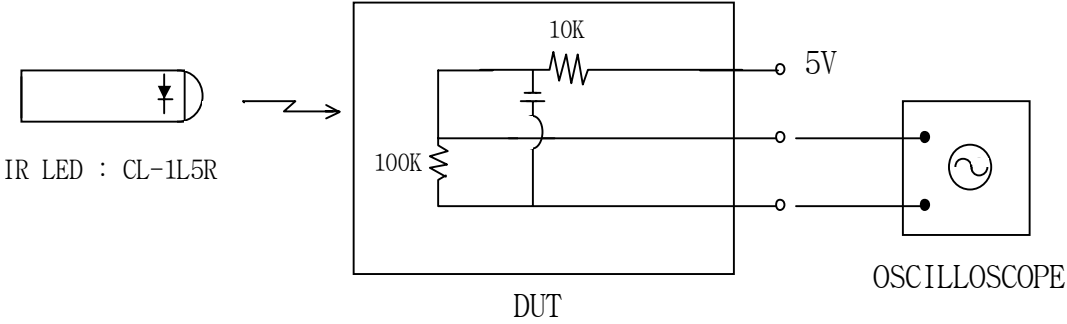

*3
*4

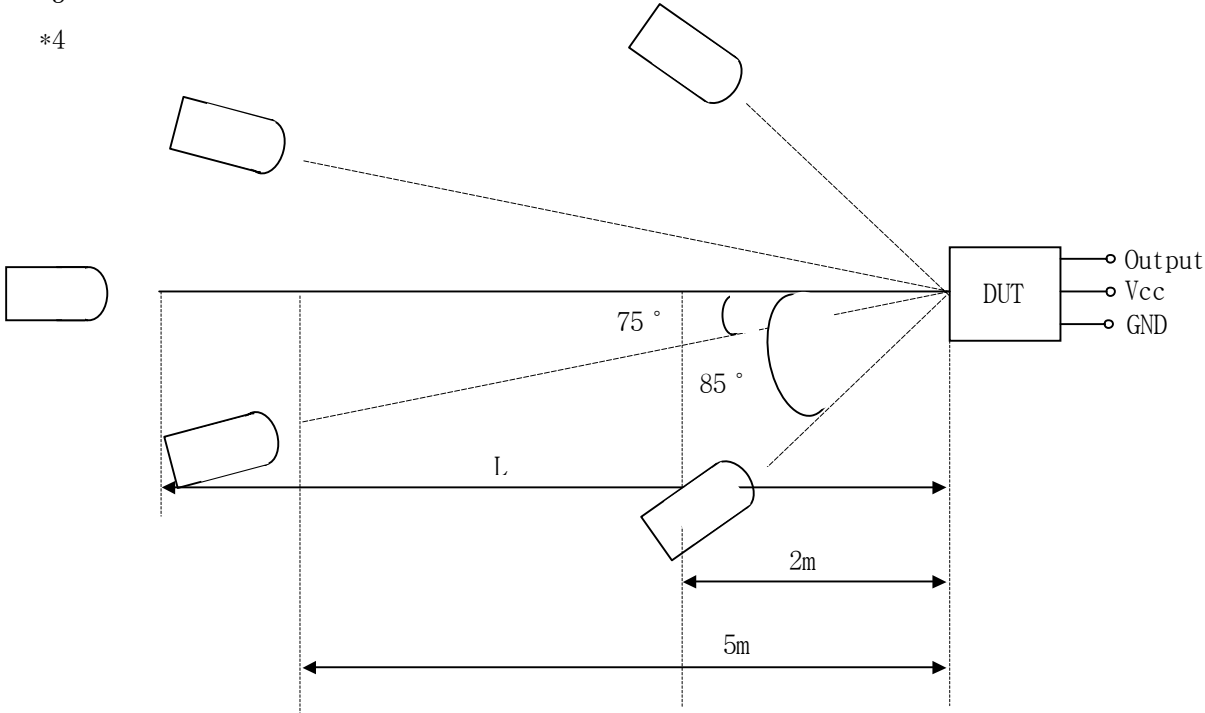

- Vcc supplies to the set power
- DUT : Device Under Test
 (70cm height from ground)

2005. 01. 17.

T I T L E	REMOCON - MODULE	PARTS NAME	346HF12A
		CODE NO.	
Application	UL, CSA, JMI, VDE, BSI, SEMKO, DEMKO, ()		

7. SCHEMATIC DIAGRAM AND PATTERN DRAWING

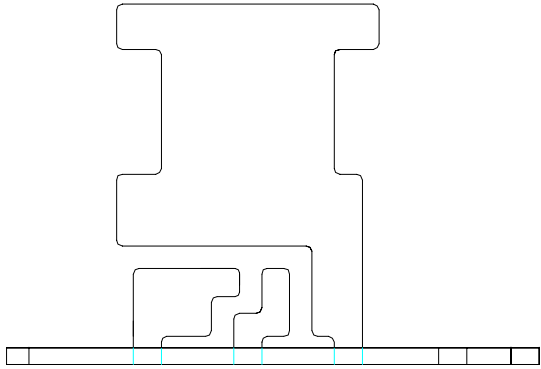
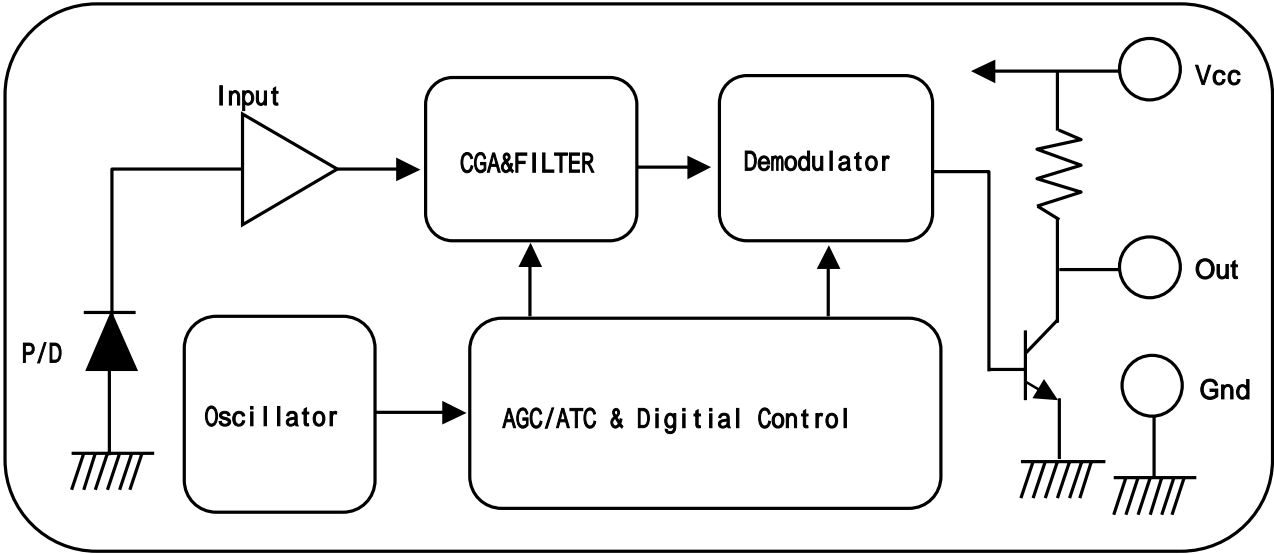

8. The Others

In case of noisy power supply, please serially insert about 47ohm resistance and about 47uF Electrolytic capacitance in Vcc line as follows.

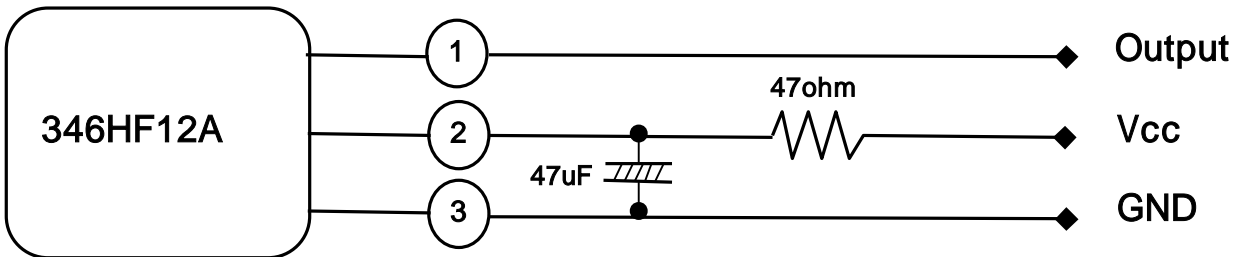

A P P R O V A L S H E E T

2005. 01. 17.

T I T L E	REMOCON - MODULE	PARTS NAME	346HF12A
		CODE NO.	
Application	UL, CSA, JMI, VDE, BSI, SEMKO, DEMKO, ()		

9. Mechanical Characteristic

Measured on usual condition and it means room temperature 25 ±2 and humidity 60~70%.

Items	Test Condition	Jugement									
Terminal Intensity	Keep the weight 500g for 30 second	No destruction									
Terminal Bend Intensity	Bend 90 with wight 250 two times each terminals	- Not depart the kapa plate. - Not cut the lead									
Drop Test	Test piece is dropped three times from the height 1m on floor.	No effect on siface structure and electric features (except the lead bent)									
Vibration Test	<table border="1" style="width: 100%; border-collapse: collapse; margin: 5px;"> <tr> <th style="width: 33%;">Frequency</th> <th style="width: 33%;">Amplitude</th> <th style="width: 33%;">Direction</th> </tr> <tr> <td style="text-align: center;">10-55-10Hz</td> <td style="text-align: center;">1.5mm</td> <td style="text-align: center;">x, y, t</td> </tr> <tr> <td colspan="3" style="text-align: center;">During 6 hours each x, y, z directions</td> </tr> </table>	Frequency	Amplitude	Direction	10-55-10Hz	1.5mm	x, y, t	During 6 hours each x, y, z directions			No destruction
Frequency	Amplitude	Direction									
10-55-10Hz	1.5mm	x, y, t									
During 6 hours each x, y, z directions											
Soldering Heat Test	Put the lead into the lead over 4 ±1mm for 3 ±0.5 second	Content the electric feature on usual condition for 1hour									
Soldering Ability Test	Put the lead into the lead pot 4 ±1mm for 3 ±0.5 second	The new lead should attach over 95%									

A P P R O V A L S H E E T

2005. 01. 17.

T I T L E	REMOCON - MODULE	PARTS NAME	346HF12A
		CODE NO.	
Application	UL, CSA, JMI, VDE, BSI, SEMKO, DEMKO, ()		

10. Reliability test

Items	Test Condition	Judgement
High humid test	Leave it on condition 40 , humid 90~95% RH, 96 HR ± 4 HR	Operating distance and angle should be satisfied
High temperature test	Leave it on condition 85 , 96 HR ± 12 HR	
Low temperature test	Leave it on condition -30 500 HR ± 12 HR	
Heat shock test	Test 20 cycle as 1 cycle that leave it on condition -20 and +70 for 2hours	
load life test	Satisfing Vcc=5V, leave it on 70 high temp. for 240 hours	
PCT test	Leave it on condition 123 , 95% RH, 1atm for 96 hours	

- Judge the result after reliability test and let alone during 1 hours.

11. Transient Change

It should keep the origin appearance and soldering conditions
after 6months on condition packing in space.

A P P R O V A L S H E E T

PAGE

8/8

2005. 01. 17.

T I T L E	REMOCON - MODULE	PARTS NAME	346HF12A
		CODE NO.	
Application	UL, CSA, JMI, VDE, BSI, SEMKO, DEMKO, ()		

12. Packing

It is should be packed against from shock and damage under delivery and storage and marked the minimal items at suitable space.

- 1) Parts Name
 - 2) CODE No.
 - 3) Specification
 - 4) Quantity
 - 5) Manufacturing Date
 - 6) The Term of Storage
 - 7) The Name of Corporation
- * Attach the packing drawing and material list

13. Manufaturing Process Flow Chart

14. Others

- MARKING SPEC'
- Product Outline Drawing
- Measuring DATA
- Reliability DATA

A P P R O V A L S H E E T

PAGE

2005. 01. 17.

T I T L E	REMOCON - MODULE	PARTS NAME	346HF12A
		CODE NO.	
Application	UL, CSA, JMI, VDE, BSI, SEMKO, DEMKO, ()		

PACKING SPECIFICATIONS

[IN BOX]

QUANTITY(pcs)	WEIGHT(g)	BOX NAME	LOADING UNIT	COMPRESSIBILITY(kg)
775	0.75	IB-100	5	1

BOX SIZE

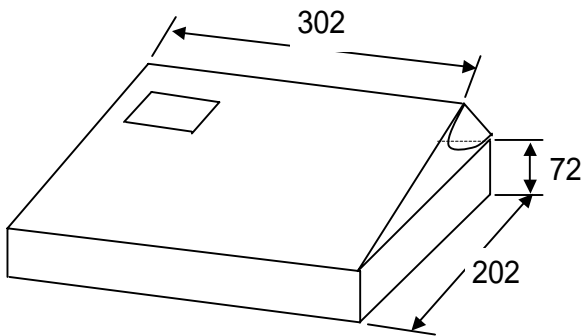

PACKING METHOD

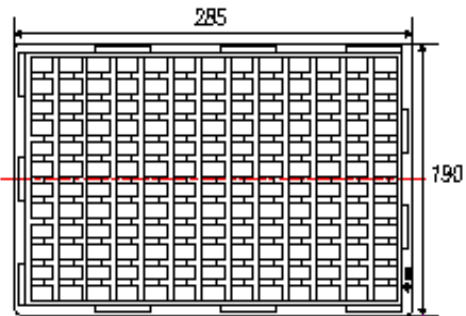

[OUT BOX]

QUANTITY(pcs)	WEIGHT(kg)	BOX NAME	LOADING UNIT	COMPRESSIBILITY(kg)
6,200(775 × 8)	8	OB-57	8	9

BOX SIZE

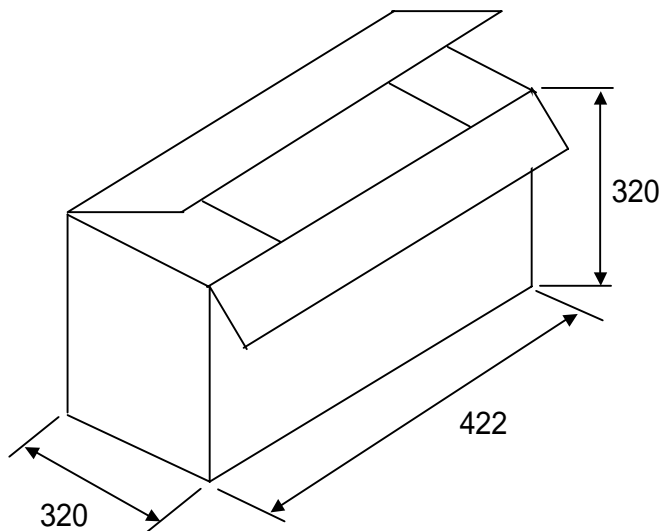

- MARKING ON THE BOX -

- 1) PRODUCT NAME
- 2) TYPE NUMBER
- 3) QUANTITY
- 4) DATE OF STORED
- 5) LOT NUMBER
- 6) QUALITY QUARANTEED
- 7) MANUFACTURE'S NAME

Unit : mm

Tolerance : ±1.0

A P P R O V A L S H E E T

PAGE	
------	--

2005. 01. 17.

T I T L E	REMOCON - MODULE	PARTS NAME	346HF12A
		CODE NO.	
Application	UL, CSA, JMI, VDE, BSI, SEMKO, DEMKO, ()		

MARKING SPECIFICATIONS

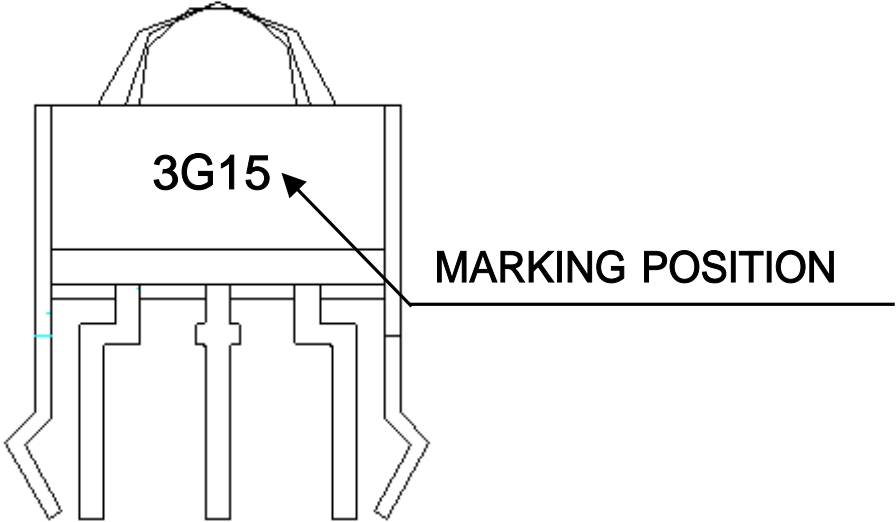

[BOTTOM VIEW]

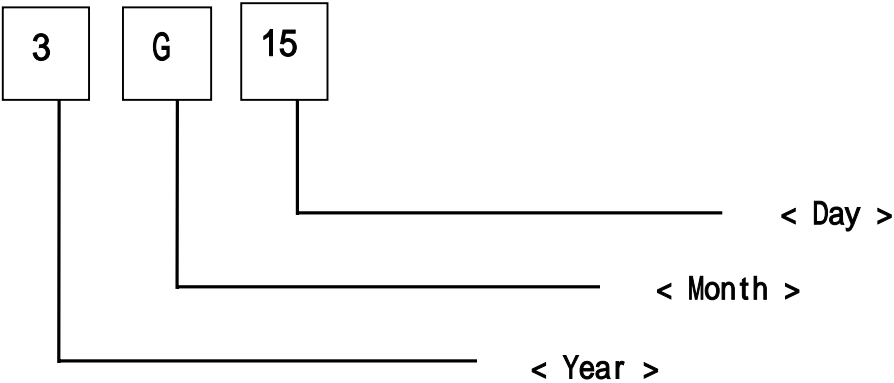

EX) 03 7 15

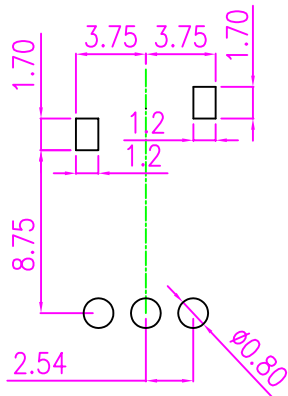
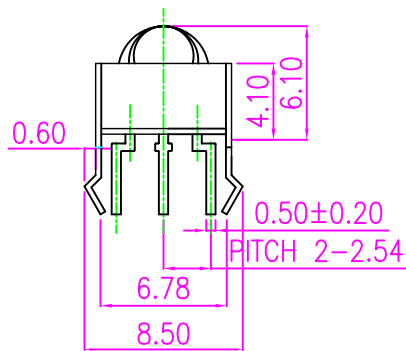
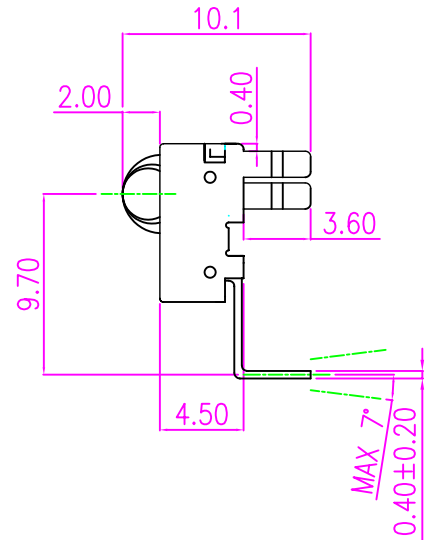
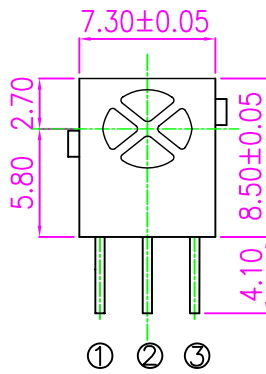
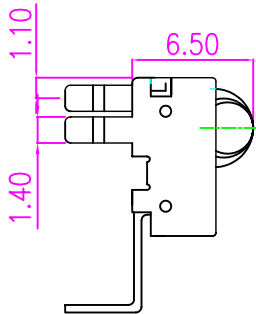

NOTE

GENERAL TOLERANCE : ±0.2

1. OUTPUT
2. Vcc
3. GND

DATE 2005.01.05.

UNIT mm

SCALE 5/1

MATERIAL

UNLESS OTHERWISE SPECIFIED DIMENSIONS ARE IN MILLIMETERS AND TOLERANCES ARE AS FOLLOWS:

0 - 6	±0.1
6 - 15	±0.15
15 - 60	±0.2
60 - 200	±0.3
200 - ∞	±0.5

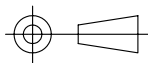

ANGULAR TOLERANCE ±0.5°

TITLE

346HF12A



OPTO ELECTRONICS CO.,LTD

D.W.G NO.

OR01-254