

**VICOR CONFIDENTIAL**

THIS DOCUMENT AND THE DATA DISCLOSED HEREIN OR HEREWITH IS NOT TO BE REPRODUCED, USED, OR DISCLOSED IN WHOLE OR IN PART TO ANYONE WITHOUT PERMISSION OF VICOR CORP.

REV.	DESCRIPTION	DATE	APPROVED
#1	DRAWN FOR DEVELOPMENT	11/10/00	GCK
#2	REVSD PER MRKUP	AK 02/12/01	GCK
#3	MATL WAS CRS, FIN WAS BRIGHT NICKEL	RCM 3/1/01	GCK
#4	SQUARE CORNERS WERE ROUNDED	DPK 4/10/01	GCK
#5	REVISED PER MARK-UP	PEI 9/14/01	GCK

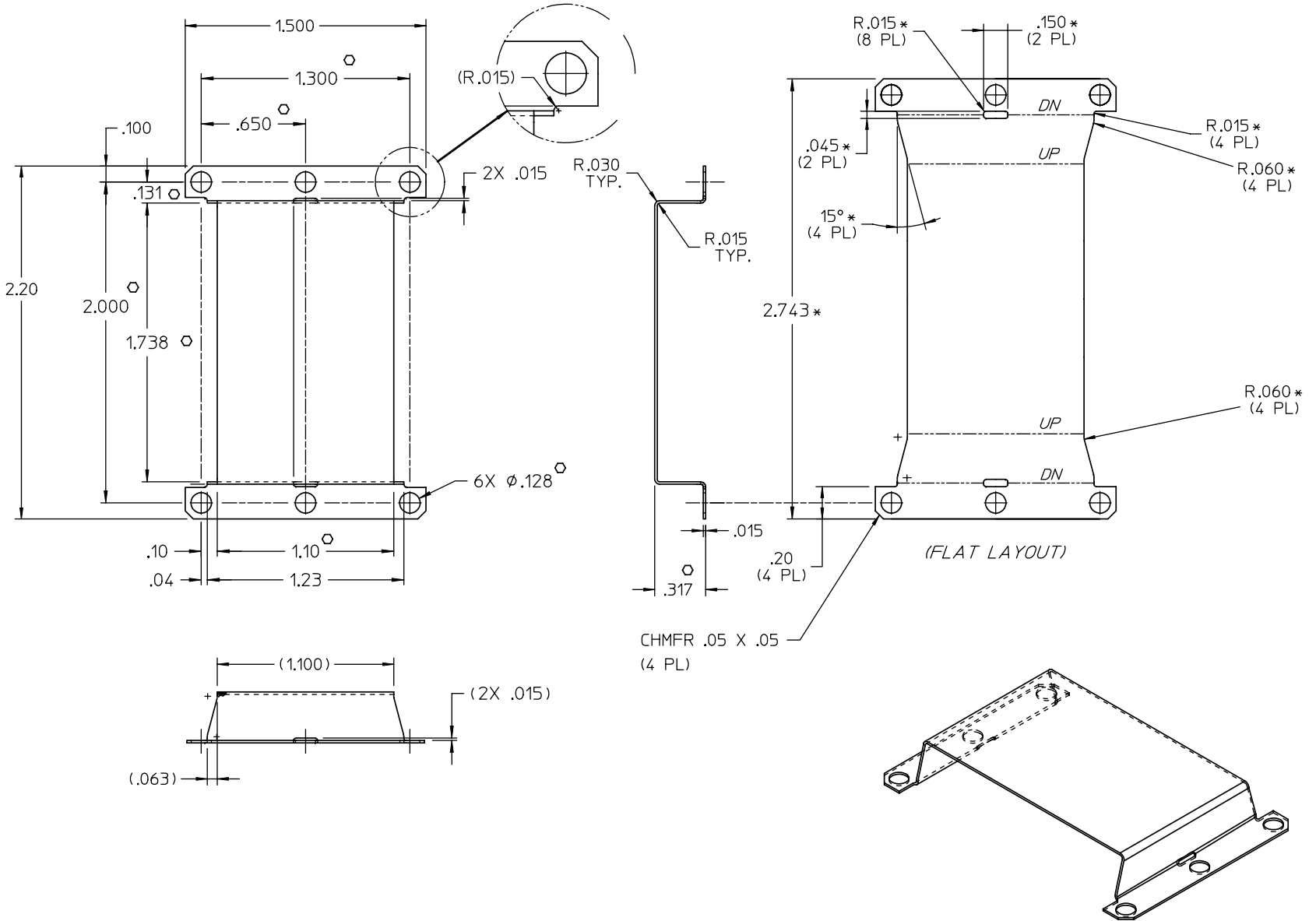

**NOTES:**

1. MATERIAL: ALUMINUM- (.015) THK, 5052
2. REMOVE BURRS & SHARP EDGES
3. "\*" DIMENSIONS ARE NOT FOR VICOR INSPECTION.
4. "o" DENOTES CRITICAL CHARACTERISTICS FOR LOT INSPECTION.
5. FINISH: CLEAR CHROMATE

DRAWN BY <i>RCM</i>	DATE 11/10/00				
<small>UNLESS OTHERWISE SPECIFIED DIMENSIONS ARE IN INCHES- FRACTIONS DECIMALS ANGLES</small> <small>*1/64 .XX=+.01 .XXX=+.005</small>					
<small>THIRD ANGLE PROJECTION</small> 		<small>SIZE</small> <b>C</b>	<small>FSCM NO.</small> <b>67131</b>	<small>DWG NO</small> <b>21313</b>	<small>REV</small> <b>#5</b>
<small>DO NOT SCALE DRAWING</small>		<small>SCALE</small> <b>2X</b>	<small>SHEET</small> <b>1</b> <small>OF</small> <b>1</b>		