

Q-Band Driver Amplifier

TGA4042-EPU

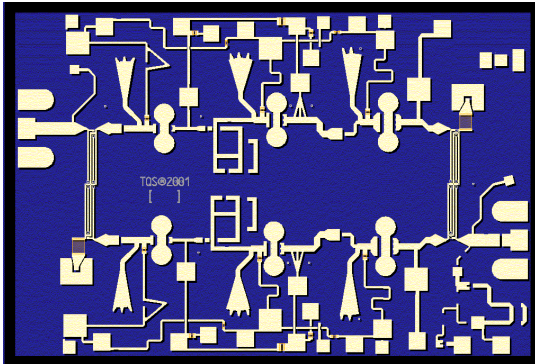

Key Features

- Typical Frequency Range: 41 - 45 GHz
- 18 dBm Nominal P1dB
- 14 dB Nominal Gain
- 17 dB Nominal Return Loss
- On-Chip Power Detector
- Bias 6 V, 168 mA
- 0.25 um 2MI pHEMT Technology
- Chip Dimensions 3.20 x 2.18 x 0.1 mm
(0.126 x 0.086 x 0.004) in

Preliminary Measured Data

Bias Conditions: $V_d = 6\text{ V}$, $I_d = 168\text{ mA}$

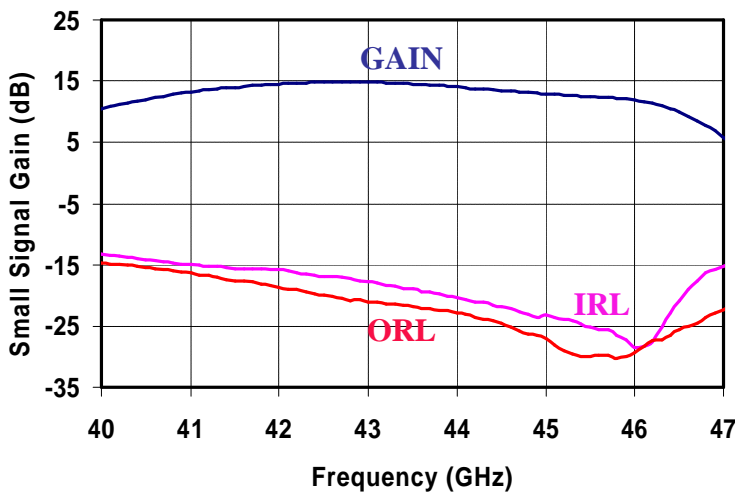

Primary Applications

- Point-to-Point Radio
- Military Radar Systems
- Q Band Sat-Com

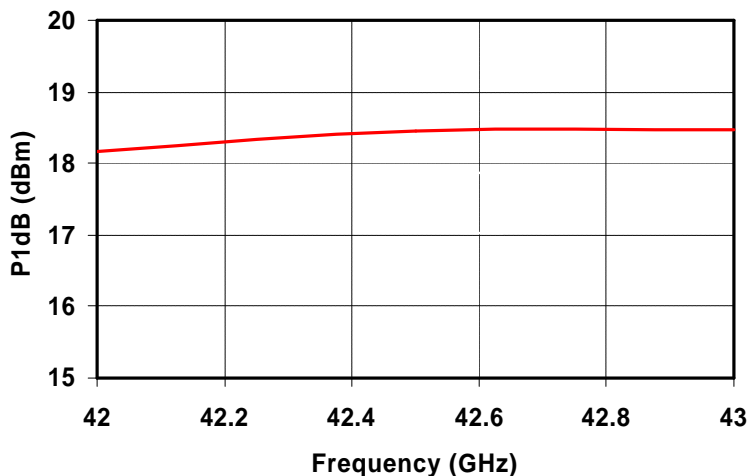

Note: Devices designated as EPU are typically early in their characterization process prior to finalizing all electrical and process specifications. Specifications are subject to change without notice

TABLE I
MAXIMUM RATINGS 1/

SYMBOL	PARAMETER	VALUE	NOTES
V _d	Drain Voltage	8 V	2/
V _g	Gate Voltage Range	-5 TO 0 V	
I _d	Drain Current	294 mA	2/ 3/
I _g	Gate Current	14 mA	3/
P _{IN}	Input Continuous Wave Power	21 dBm	
P _D	Power Dissipation	3.3 W	2/ 4/
T _{CH}	Operating Channel Temperature	150 °C	5/ 6/
T _M	Mounting Temperature (30 Seconds)	320 °C	
T _{STG}	Storage Temperature	-65 to 150 °C	

- 1/ These ratings represent the maximum operable values for this device.
- 2/ Combinations of supply voltage, supply current, input power, and output power shall not exceed P_D.
- 3/ Total current for the entire MMIC.
- 4/ When operated at this bias condition with a base plate temperature of 70 °C, the median life is reduced to 1E+6 hrs.
- 5/ Junction operating temperature will directly affect the device median time to failure (MTTF). For maximum life, it is recommended that junction temperatures be maintained at the lowest possible levels.
- 6/ These ratings apply to each individual FET.

TABLE II
DC PROBE TESTS
(T_a = 25 °C, Nominal)

SYMBOL	PARAMETER	MIN.	TYP.	MAX.	UNITS
I _{DSS,Q1}	Saturated Drain Current	20	57	94	mA
G _{M,Q1}	Transconductance	44	75	106	mS
V _{BVGS,Q1}	Breakdown Voltage Gate-Source	-30	-21	-8	V
V _{BVGD,Q1 & Q3}	Breakdown Voltage Gate-Drain	-30	-21	-8	V
V _{P,Q1-Q6}	Pinch-Off Voltage	-1.5	-1	-0.5	V

Q1 & Q2 are 200 um FETs, Q3 & Q4 are 240 um FETs, Q5 & Q6 are 400 um FETs

Note: Devices designated as EPU are typically early in their characterization process prior to finalizing all electrical and process specifications. Specifications are subject to change without notice

TABLE III
ELECTRICAL CHARACTERISTICS
(Ta = 25 °C, Nominal)

PARAMETER	TYPICAL	UNITS
Frequency Range	41 - 45	GHz
Drain Voltage, Vd	6	V
Drain Current, Id	168	mA
Gate Voltage, Vg	-0.5	V
Small Signal Gain, S21	14	dB
Input Return Loss, S11	17	dB
Output Return Loss, S22	20	dB
Output Power @ 1 dB Compression Gain, P1dB	18	dBm

TABLE IV
THERMAL INFORMATION

PARAMETER	TEST CONDITIONS	T _{CH} (°C)	R _{qJC} (°C/W)	T _M (HRS)
R _{θJC} Thermal Resistance (channel to backside of carrier)	Vd = 6 V I _D = 168 mA P _{diss} = 1.008 W	92.58	22.40	2.7E+8

Note: Assumes eutectic attach using 1.5 mil 80/20 AuSn mounted to a 20 mil CuMo Carrier at 70°C baseplate temperature. Worst case condition with no RF applied, 100% of DC power is dissipated.

Note: Devices designated as EPU are typically early in their characterization process prior to finalizing all electrical and process specifications. Specifications are subject to change without notice

Preliminary Measured Data

Bias Conditions: $V_d = 6\text{ V}$, $I_d = 168\text{ mA}$, Room Temp.

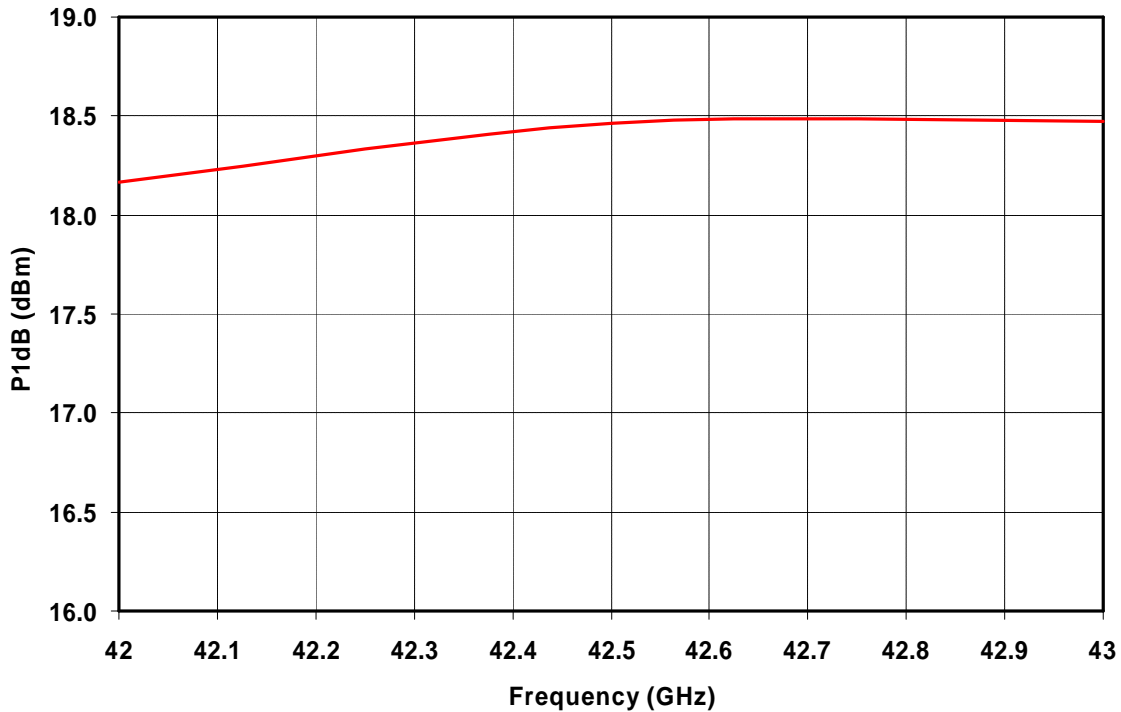
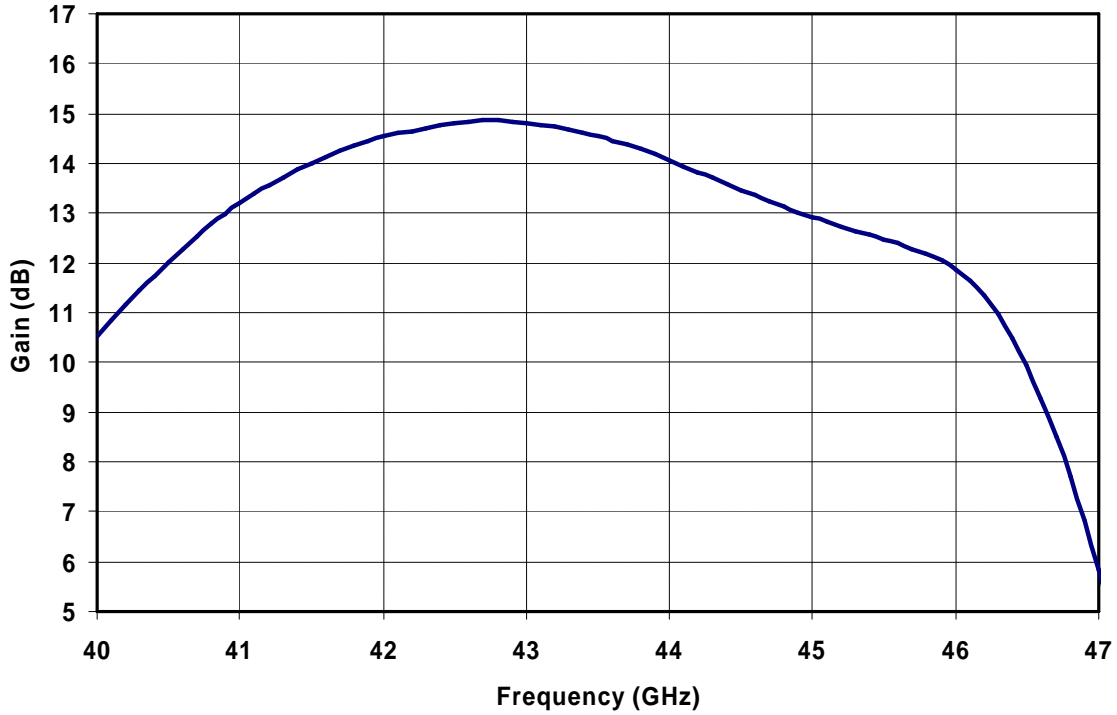

Note: Devices designated as EPU are typically early in their characterization process prior to finalizing all electrical and process specifications. Specifications are subject to change without notice

Preliminary Measured Data

Bias Conditions: $V_d = 6\text{ V}$, $I_d = 168\text{ mA}$, Room Temp.

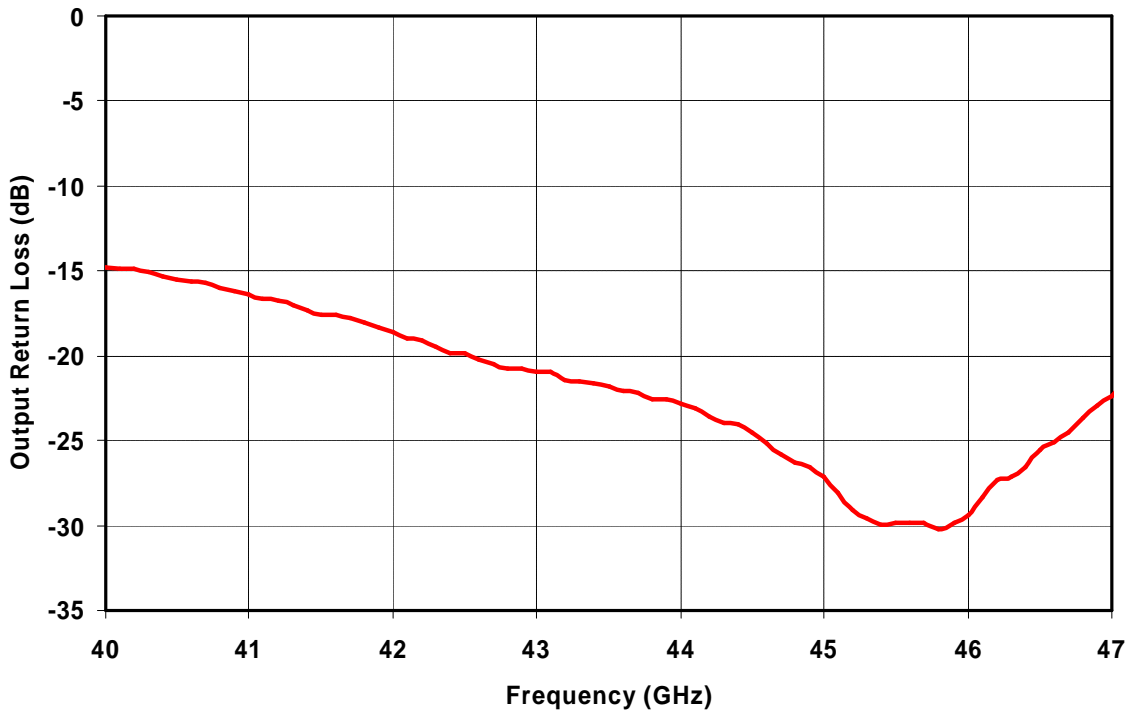
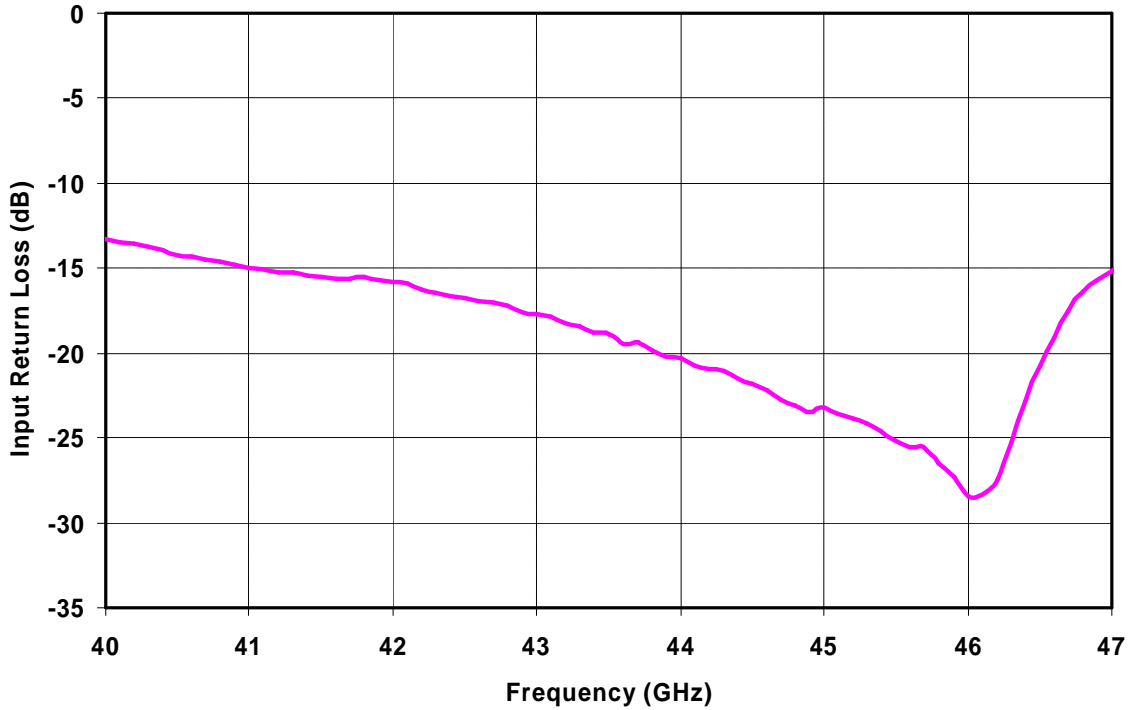

Note: Devices designated as EPU are typically early in their characterization process prior to finalizing all electrical and process specifications. Specifications are subject to change without notice

Preliminary Measured Data

Bias Conditions: $V_d = 6\text{ V}$, $I_d = 168\text{ mA}$

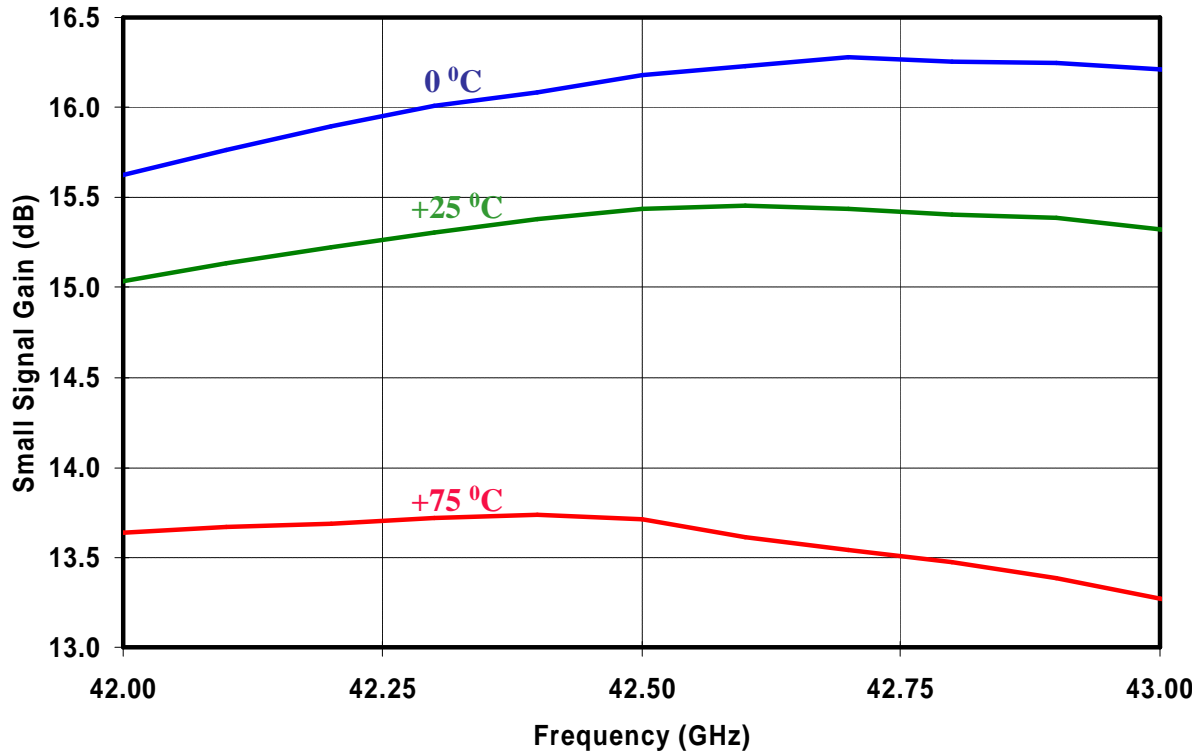

Note: Devices designated as EPU are typically early in their characterization process prior to finalizing all electrical and process specifications. Specifications are subject to change without notice

Mechanical Drawing

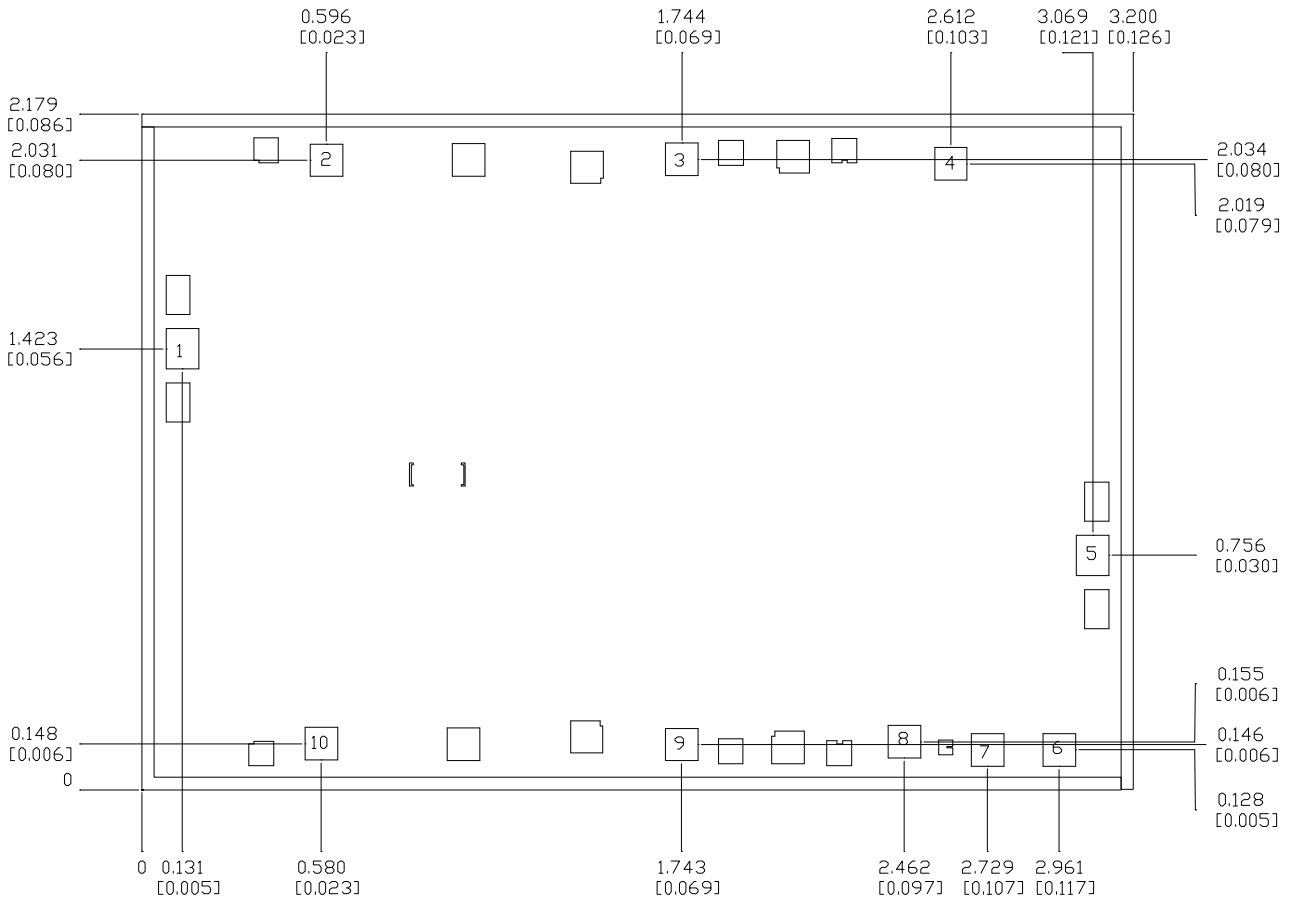

Units: Millimeters (inches)

Thickness: 0.100 (0.004) (reference only)

Chip edge to bond pad dimensions are shown to center of bond pad

Chip size tolerance: +/- 0.051 (0.002)

RF Ground is backside of MMIC

Bond pad #1	(RF Input)	0.105 x 0.130	<0.004 x 0.005
Bond pad #2 & #10	(Vg)	0.105 x 0.105	<0.004 x 0.004
Bond pad #3, #4, #8, #9	(Vd)	0.105 x 0.105	<0.004 x 0.004
Bond pad #5	(RF Output)	0.105 x 0.130	<0.004 x 0.005
Bond pad #6	(Vdet)	0.105 x 0.105	<0.004 x 0.004
Bond pad #7	(Vcomp)	0.105 x 0.105	<0.004 x 0.004

GaAs MMIC devices are susceptible to damage from Electrostatic Discharge. Proper precautions should be observed during handling, assembly and test.

Note: Devices designated as EPU are typically early in their characterization process prior to finalizing all electrical and process specifications. Specifications are subject to change without notice

Chip Assembly Diagram

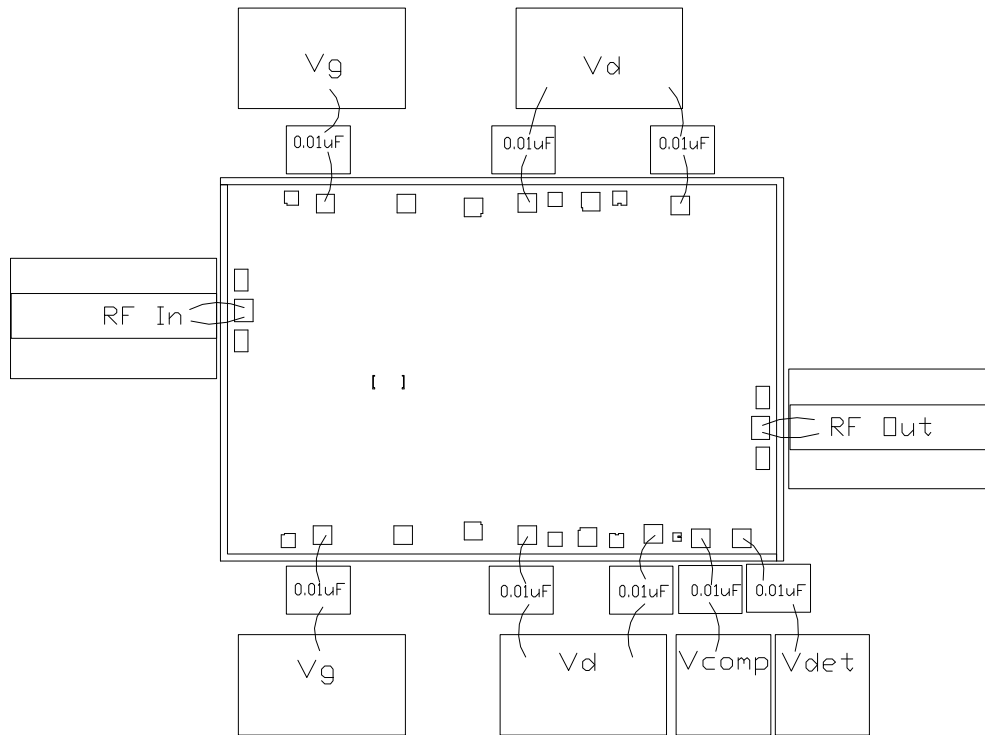

Power Detector Bias Circuit

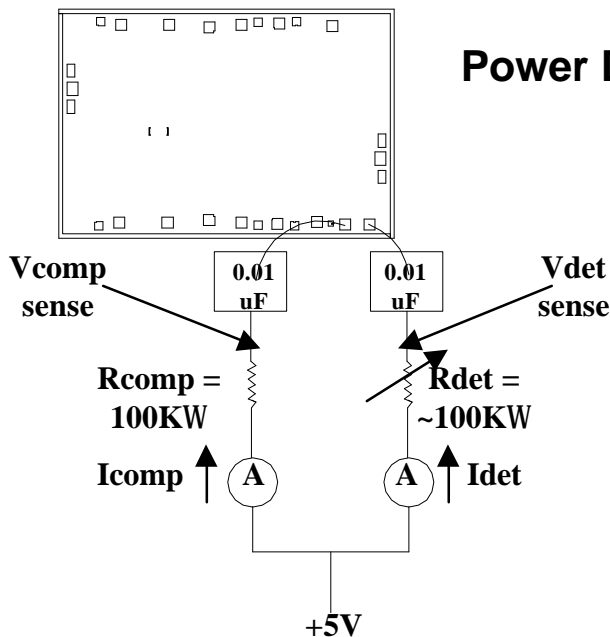

Note:

1. With no RF power applied, adjust Rdet until Idet = Icomp (approx 41uA) and record Vdet.
2. Record Vdet as Pout increases. Detector sensitivity at a particular Pout is defined as delta between Vdet at Pout of interest and Vdet with no Pout.

GaAs MMIC devices are susceptible to damage from Electrostatic Discharge. Proper precautions should be observed during handling, assembly and test.

Note: Devices designated as EPU are typically early in their characterization process prior to finalizing all electrical and process specifications. Specifications are subject to change without notice

Power Detector performance over temperature

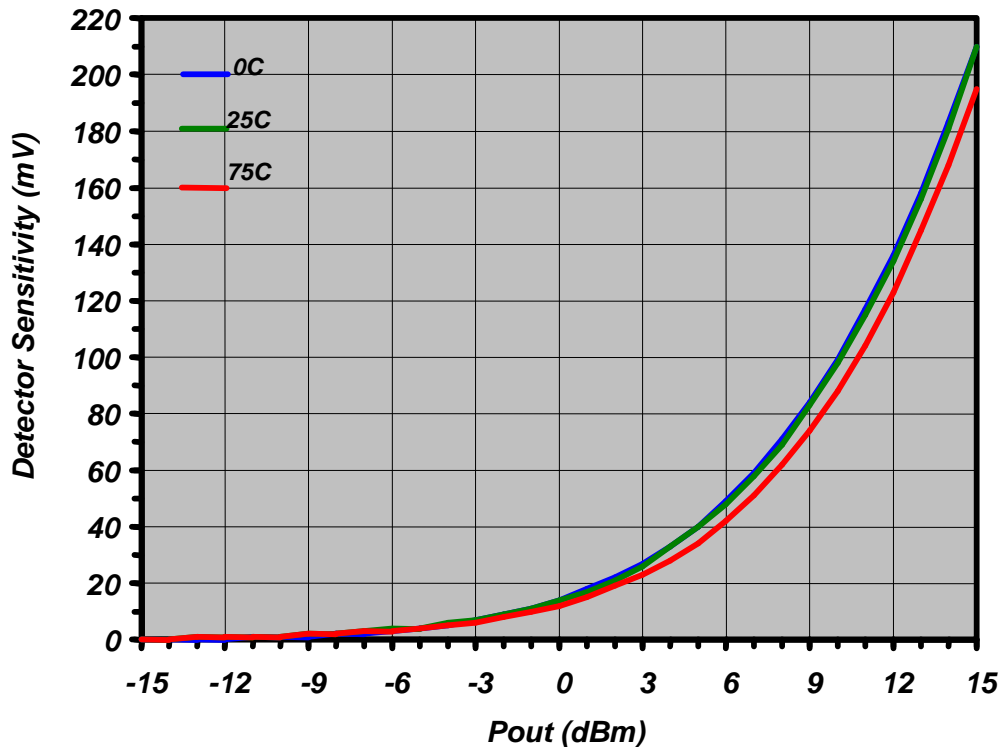
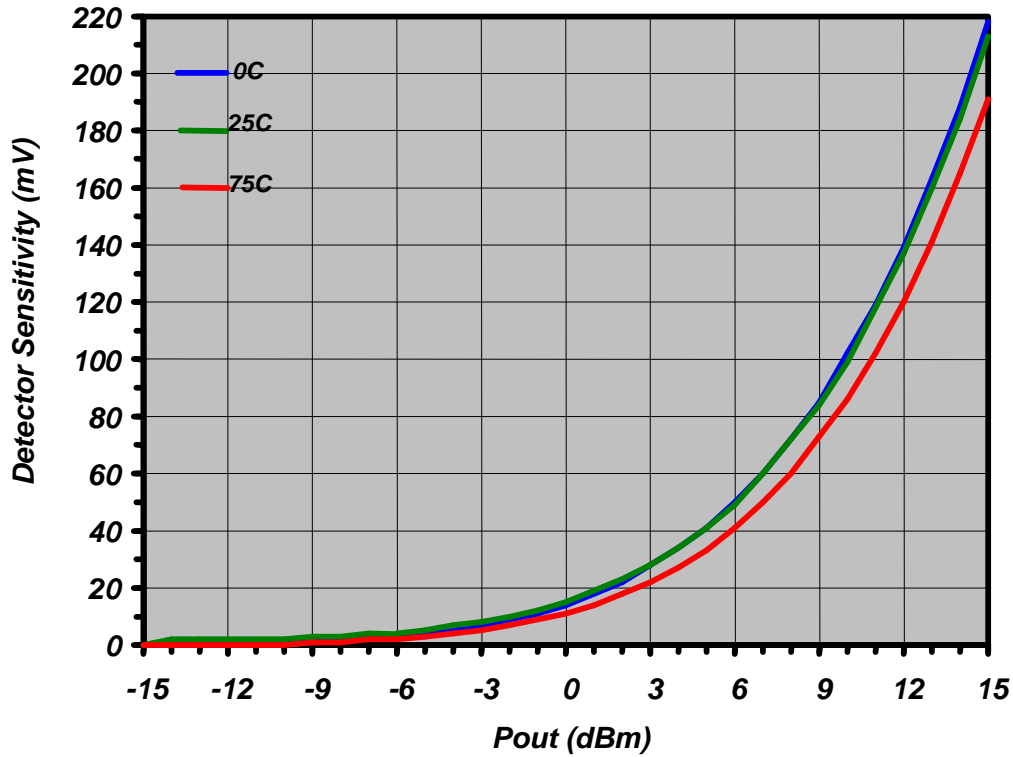

Note: Devices designated as EPU are typically early in their characterization process prior to finalizing all electrical and process specifications. Specifications are subject to change without notice

Assembly Process Notes

Reflow process assembly notes:

- Use AuSn (80/20) solder with limited exposure to temperatures at or above 300⁰C (30 seconds max).
- An alloy station or conveyor furnace with reducing atmosphere should be used.
- No fluxes should be utilized.
- Coefficient of thermal expansion matching is critical for long-term reliability.
- Devices must be stored in a dry nitrogen atmosphere.

Component placement and adhesive attachment assembly notes:

- Vacuum pencils and/or vacuum collets are the preferred method of pick up.
- Air bridges must be avoided during placement.
- The force impact is critical during auto placement.
- Organic attachment can be used in low-power applications.
- Curing should be done in a convection oven; proper exhaust is a safety concern.
- Microwave or radiant curing should not be used because of differential heating.
- Coefficient of thermal expansion matching is critical.

Interconnect process assembly notes:

- Thermosonic ball bonding is the preferred interconnect technique.
- Force, time, and ultrasonics are critical parameters.
- Aluminum wire should not be used.
- Maximum stage temperature is 200⁰C.

GaAs MMIC devices are susceptible to damage from Electrostatic Discharge. Proper precautions should be observed during handling, assembly and test.

Note: Devices designated as EPU are typically early in their characterization process prior to finalizing all electrical and process specifications. Specifications are subject to change without notice