

VICOR CONFIDENTIAL  
 THIS DOCUMENT AND THE DATA DISCLOSED  
 HEREIN OR HEREWITH IS NOT TO BE REPRODUCED,  
 USED, OR DISCLOSED IN WHOLE OR IN PART  
 TO ANYONE WITHOUT PERMISSION OF VICOR CORP.

REV.	DESCRIPTION	DATE	APPROVED
#1	RELEASED FOR DEVELOPMENT	DPK 4/28/97	SWN
#2	REVISED AND REDRAWN	DPK 11/17/97	SWN
#3	ADDED +.010 TOL TO DIM	DPK 12/8/97	SWN
#4	REMOVED P/N STAMPING	DPK 8/24/98	SWN
#5	.40 WAS .400: ADDED 'O' TO .100 & .190	DPK 9/10/98	SWN
#6	ADDED NOTE 4 CRITICAL CHA. 'O'	AK 10/7/99	SWN

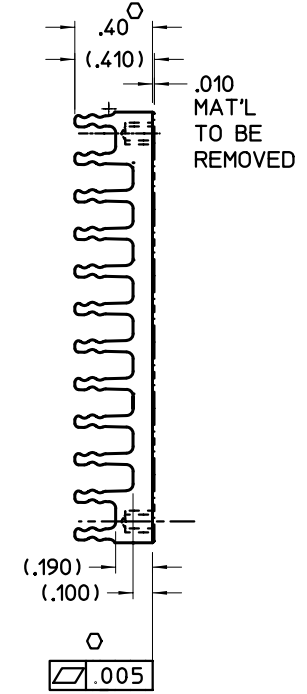
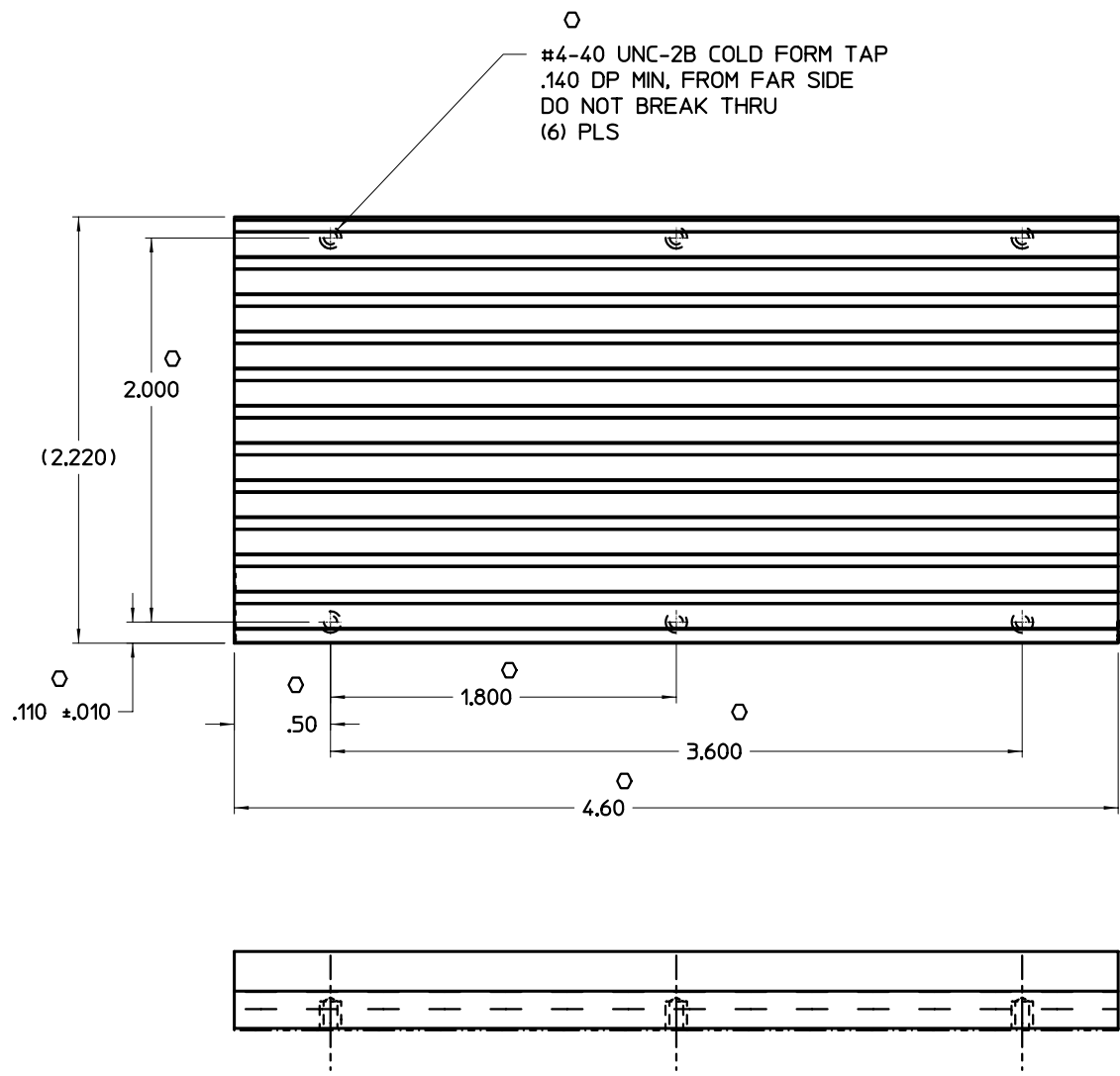

- NOTES
1. MAKE FROM VICOR EXTRUSION P/N 17475.
  2. REMOVE ALL BURRS AND SHARP EDGES.
  3. FINISH: CLEAR CHROMATE.
  4. \*O\* DENOTES CRITICAL CHARACTERISTIC FOR LOT INSPECTION.

DRAWN BY <b>D.P. KELLY</b>	DATE <b>4/97</b>		
<small>UNLESS OTHERWISE SPECIFIED          DIMENSIONS ARE IN INCHES          TOLERANCES ARE:          FRACTIONS DECIMALS ANGLES          1/64 .001 .01 1/2° .005 .1°</small>		<b>HTSNK "A" LONG .4H          LOW FLOW, THREADED</b>	
THIRD ANGLE PROJECTION 	SIZE <b>C 67131</b>	DWG NO <b>17483</b>	REV <b># 6</b>
DO NOT SCALE DRAWING	SCALE <b>2-1</b>	SHEET <b>1</b>	OF <b>1</b>