

HIGH SPEED LAN MAGNETICS

- For use in ATM155 Mbps, 100Base-TX or 100 Mbps TP-FDDI applications
- Compatible with a variety of PHY transceivers
- Space efficient, narrow body SIP packaging
- Dual common mode choke design for high isolation and low common mode emissions
- 2000 Vrms isolation

ELECTRICALS AT 25°C

Part No.	Insertion Loss (dB) Typ 1MHz-100MHz	Return Loss (dB) Min 1MHz-30MHz	Return Loss (dB) Min 30MHz-60MHz	Return Loss (dB) Min 60MHz-80MHz	Crosstalk (dB) Min 1MHz-100MHz	Common to Diff Mode Rej (dB) Min		Common to Common Mode Rej (dB) Min		Schematic
						30MHz	100MHz	30MHz	100MHz	
0558-5999-14	-1.0	-16	16-20log(f/30MHz)	-10	-30	-50	-40	-40	-30	B
0558-5999-33	-1.0	-16	16-20log(f/30MHz)	-10	-30	-50	-40	-40	-30	A

SCHEMATICS

A

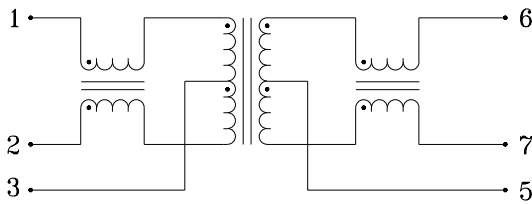

B

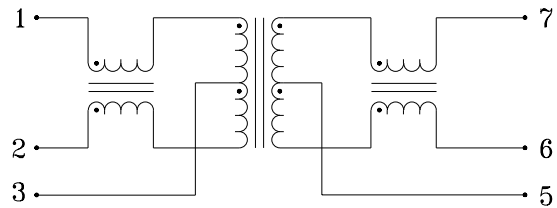

MECHANICAL

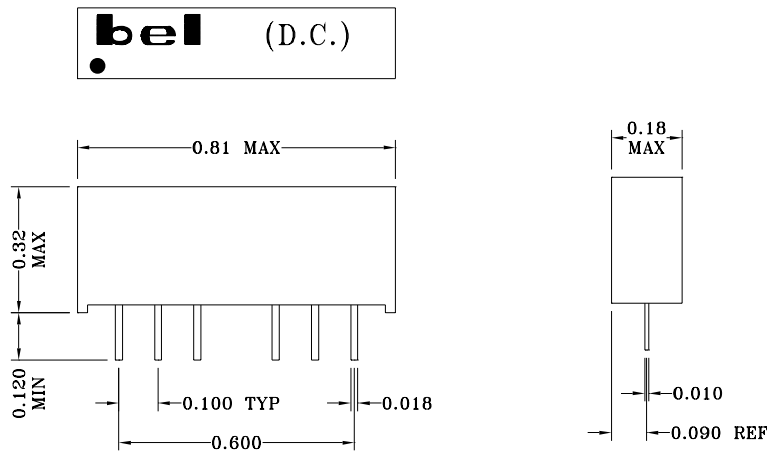

Specifications subject to change without notice.

APPLICATION CIRCUIT

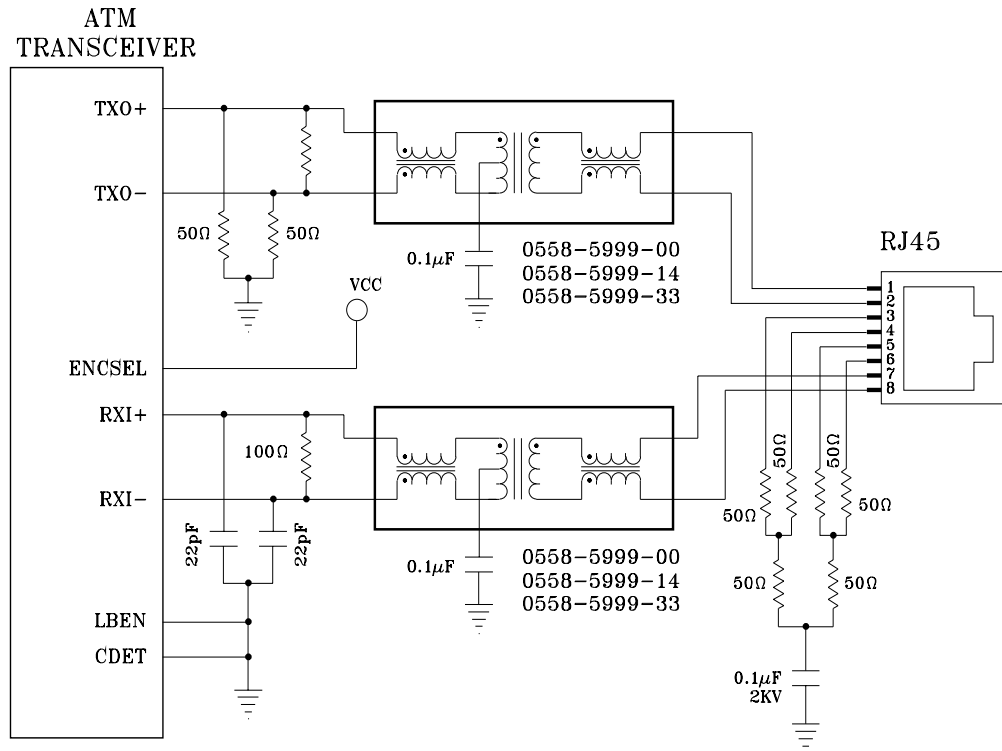

APPLICATION NOTES

- The 0558-5999-14 and 0558-5999-33 have been designed for use in 100 Mbps TP-FDDI, 100Base-TX and 155 Mbps ATM data transmission systems utilizing either 100 ohm UTP or 150 ohm STP cable. Each Bel part provides high voltage isolation, signal wave shaping, superior EMI noise suppression and fast, but controlled rise times. All Bel parts meet IEEE 802.3, ANSI X3T9.5 and ATM Forum Committee standards. All Bel parts provide 350μH of OCL (inductance) with 8mA of DC bias applied.

Corporate Office

Bel Fuse Inc.
198 Van Vorst Street, Jersey City, NJ 07302-4496
Tel: 201-432-0463
Fax: 201-432-9542
E-Mail: BelFuse@belfuse.com
Internet: <http://www.belfuse.com>

Far East Office

Bel Fuse Ltd.
8F/8 Luk Hop Street
San Po Kong
Kowloon, Hong Kong
Tel: 852-2328-5515
Fax: 852-2352-3706

European Office

Bel Fuse Europe Ltd.
Preston Technology Management Centre
Marsh Lane, Preston PR1 8UD
Lancashire, U.K.
Tel: 44-1772-556601
Fax: 44-1772-888366