

Working voltage 5V

DESCRIPTION

The STE0511 are designed by TVS device that is to protect sensitive electronics from damage or latch-up due to ESD. They are designed for use in applications where board space is at a premium.

STE0511 is single TVS devices that will protect up to single line, and may be used on lines where the signal polarities swing above and below ground.

STE0511 offer desirable characteristics for board level protection including fast response time, low operating and clamping voltage and no device degradation.

STE0511 may be used to meet the immunity requirements of IEC 61000-4-2, level 4. The small SOD-523 package makes them ideal for use in portable electronics such as cell phone, PDA's, notebook computers, digital cameras and MP3.

PIN CONFIGURATION**SOD-523****FEATURE**

- Transient protection for data lines to IEC 61000-4-2 (ESD) +/- 15kV (air), +/-8KV (contact)
IEC 61000-4-4 (EFT) 40A (5/50ns)
- Protects single I/O lines
- Working voltage : 5V
- Low leakage current
- Low operating and clamping voltages

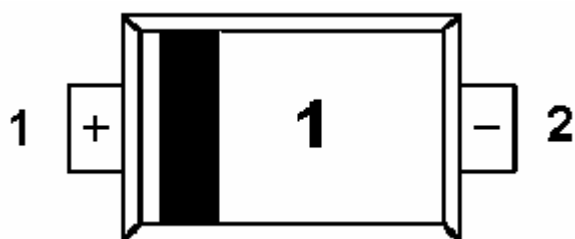
PART MARKING**STANSON TECHNOLOGY**

120 Bentley Square, Mountain View, Ca 94040 USA

TEL: (650) 9389294 FAX: (650) 9389295

Working voltage 5V

OREDRING INFORMATION

Part Number	Package
STE0511D52RG	SOD-523

STE0511D52RG: Tape Reel; Pb-Free

ABSOLUTE MAXIMUM RATINGS (Ta = 25 Unless otherwise noted)

Parameter	Symbol	Typical	Unit
Peak Pulse Power (tp=8/20 us)	Ppk	250	W
Maximum Peak Pulse Current (tp=8/20us)	Ipp	7	A
ESD per ICE 61000-4-2 (Air)	Vpp	+/-15	KV
ESD per ICE 61000-4-2 (Contact)	Vpp	+/-8	KV
Operating Junction Temperature	Tj	-55~150	
Storage Temperature Range	TSTG	-55~150	
Lead Soldering Temperature	TL	260(10sec)	

ELECTRICAL CHARACTERISTICS (Ta = 25 Unless otherwise noted)

Parameter	Symbol	Conditions	Min	Typ	Max	Unit
Reverse Stand-Off Voltage	V _{RWM}				5	V
Reverse Breakdown Voltage	V _{BR}	It=1mA	6		8.5	V
Reverse Leakage Current	I _R	V _{RWM} =5V, T=25		0.01	1	uA
Reverse Leakage Current	I _R	V _{RWM} =3V, T=25		0.01	0.5	uA
Clamping Voltage	V _C	Ipp=1A, tp=8/20us			11.5	V
Clamping Voltage	V _C	Ipp=7A, tp=8/20us			15	V
Junction Capacitance	Cj	Between I/O Pin and GND V _R =0V, f 1MHz		20	30	pF

**STANSON TECHNOLOGY**

120 Bentley Square, Mountain View, Ca 94040 USA

TEL: (650) 9389294 FAX: (650) 9389295

Working voltage 5V

TYPICAL CHARACTERISTICS

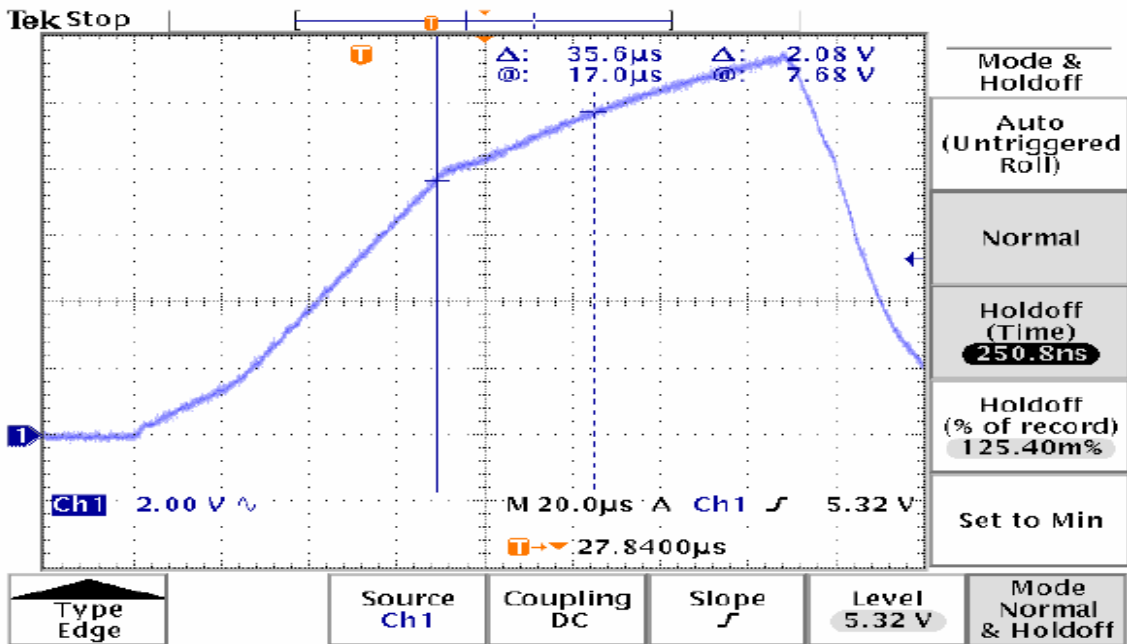
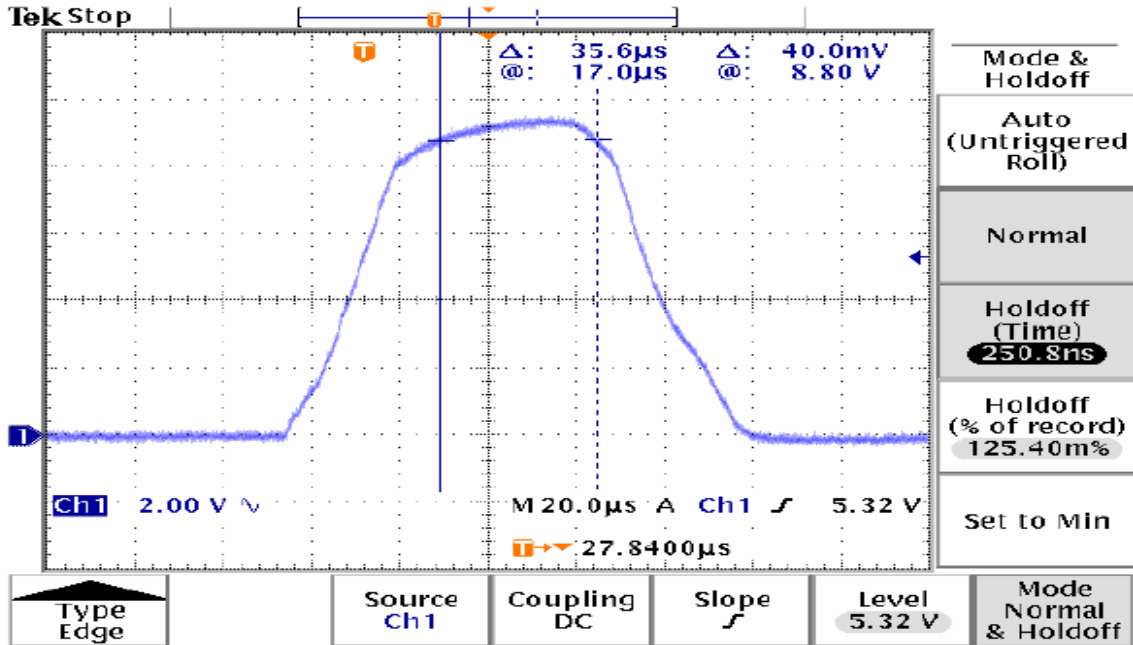

STANSON TECHNOLOGY

120 Bentley Square, Mountain View, Ca 94040 USA

TEL: (650) 9389294 FAX: (650) 9389295

Working voltage 5V

SOD-523 PACKAGE OUTLINE

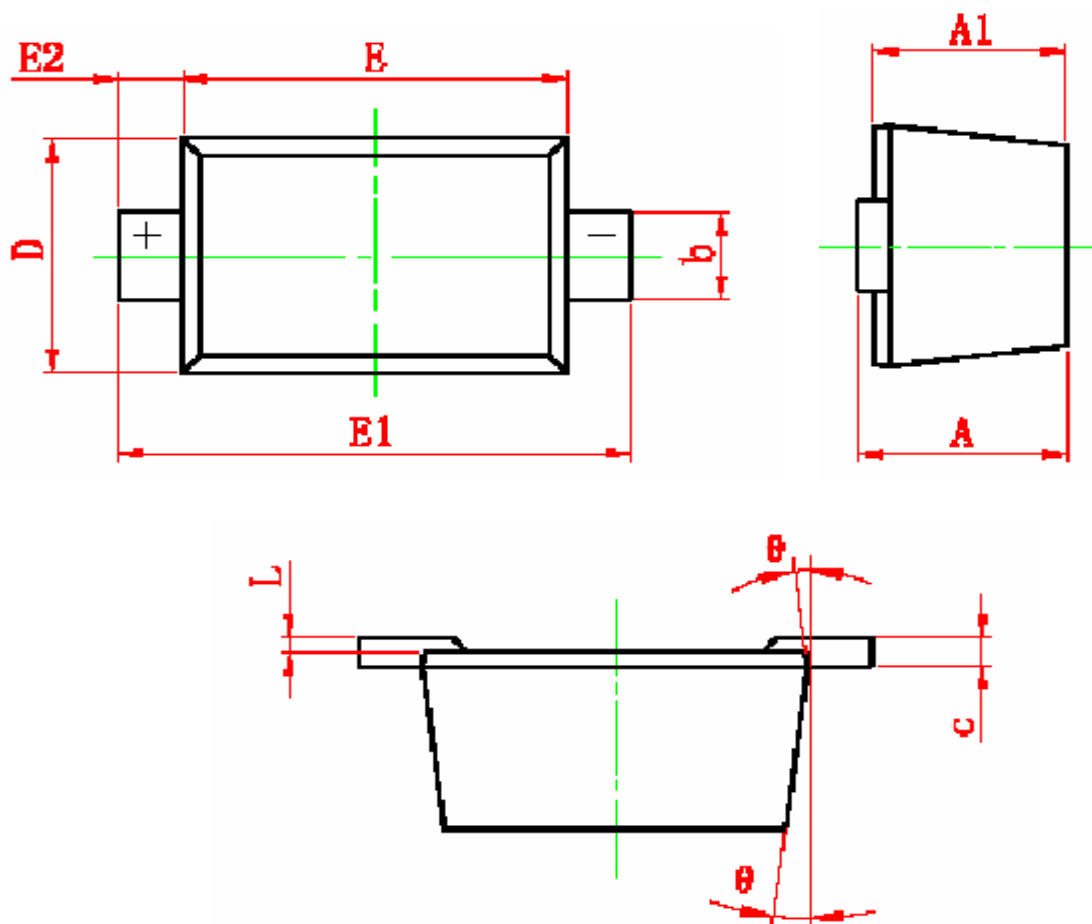

Symbol	Dimensions in Millimeters		Dimensions in Inches	
	Min	Max	Min	Max
A	0.510			
A1	0.500			
b	0.250			
c	0.080			
D	0.750			
E	1.100			
E1	1.500			
E2	0.200REF		0.008REF	
L	0.010			
	?? REF		?? REF	



STANSON TECHNOLOGY

120 Bentley Square, Mountain View, Ca 94040 USA

TEL: (650) 9389294 FAX: (650) 9389295