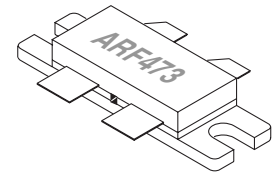
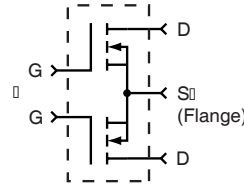

RF POWER MOSFET

N-CHANNEL ENHANCEMENT MODE

165 V 300 W 150 MHz

The ARF473 is a matched pair of RF power transistors in a common source configuration. It is designed for high voltage push-pull or parallel operation in narrow band ISM and MRI power amplifiers up to 150 MHz.

- **Specified 135 Volt, 130 MHz Characteristics:**
 - Output Power = 300 Watts.**
 - Gain = 13dB (Class AB)**
 - Efficiency = 50%**
- **High Performance Push-Pull RF Package.**
- **High Voltage Breakdown and Large SOA for Superior Ruggedness.**
- **Low Thermal Resistance.**

MAXIMUM RATINGS

 All Ratings: $T_C = 25^\circ\text{C}$ unless otherwise specified.

Symbol	Parameter	ARF473	UNIT
V_{DSS}	Drain-Source Voltage	500	Volts
I_D	Continuous Drain Current @ $T_C = 25^\circ\text{C}$ (each device)	10	Amps
V_{GS}	Gate-Source Voltage	± 30	Volts
P_D	Total Device Dissipation @ $T_C = 25^\circ\text{C}$	500	Watts
T_J, T_{STG}	Operating and Storage Junction Temperature Range	-55 to 200	°C
T_L	Lead Temperature: 0.063" from Case for 10 Sec.	300	

STATIC ELECTRICAL CHARACTERISTICS

Symbol	Characteristic / Test Conditions	MIN	TYP	MAX	UNIT
BV_{DSS}	Drain-Source Breakdown Voltage ($V_{GS} = 0V, I_D = 250 \mu\text{A}$)	500			Volts
$V_{DS(ON)}$	On State Drain Voltage ^① ($I_{D(ON)} = 5A, V_{GS} = 10V$)			4	
I_{DSS}	Zero Gate Voltage Drain Current ($V_{DS} = V_{DSS}, V_{GS} = 0V$)			25	μA
	Zero Gate Voltage Drain Current ($V_{DS} = 50V, V_{GS} = 0, T_C = 125^\circ\text{C}$)			250	
I_{GSS}	Gate-Source Leakage Current ($V_{GS} = \pm 30V, V_{DS} = 0V$)			± 100	nA
g_{fs}	Forward Transconductance ($V_{DS} = 25V, I_D = 5A$)	4	6		mhos
g_{fs1}/g_{fs2}	Forward Transconductance Match Ratio ($V_{DS} = 25V, I_D = 5A$)	0.9		1.1	
$V_{GS(TH)}$	Gate Threshold Voltage ($V_{DS} = V_{GS}, I_D = 200\text{mA}$)	3		5	Volts
$\Delta V_{GS(TH)}$	Gate Threshold Voltage Match ($V_{DS} = V_{GS}, I_D = 200\text{mA}$)			0.1	

THERMAL CHARACTERISTICS

Symbol	Characteristic	MIN	TYP	MAX	UNIT
$R_{\theta JC}$	Junction to Case			0.35	°C/W
$R_{\theta CS}$	Case to Sink (Use High Efficiency Thermal Joint Compound and Planar Heat Sink Surface.)		0.1		

 **CAUTION:** These Devices are Sensitive to Electrostatic Discharge. Proper Handling Procedures Should Be Followed.

APT Website - <http://www.advancedpower.com>

Symbol	Characteristic	Test Conditions	MIN	TYP	MAX	UNIT
C_{iss}	Input Capacitance	$V_{GS} = 0V$ $V_{DS} = 50V$ $f = 1\text{ MHz}$		1200	1600	pF
C_{oss}	Output Capacitance			140	200	
C_{rss}	Reverse Transfer Capacitance			9	12	
$t_{d(on)}$	Turn-on Delay Time	$V_{GS} = 15V$ $V_{DD} = 0.5 V_{DSS}$ $I_D = I_{D[Cont.]} @ 25^\circ C$ $R_G = 1.6 \Omega$		5.1	10	ns
t_r	Rise Time			4.1	8	
$t_{d(off)}$	Turn-off Delay Time			12.8	20	
t_f	Fall Time			4.0	8	

FUNCTIONAL CHARACTERISTICS (Push-Pull Configuration)

Symbol	Characteristic	Test Conditions	MIN	TYP	MAX	UNIT
G_{PS}	Common Source Amplifier Power Gain	$f = 130\text{MHz}$	13	14		dB
η	Drain Efficiency	$I_{dq} = 150\text{mA}$ $V_{DD} = 135V$	50	55		%
Ψ	Electrical Ruggedness VSWR 5:1	$P_{out} = 300W$	No Degradation in Output Power			

① Pulse Test: Pulse width < 380 μs , Duty Cycle < 2%.

APT Reserves the right to change, without notice, the specifications and information contained herein.

Per transistor section unless otherwise specified.

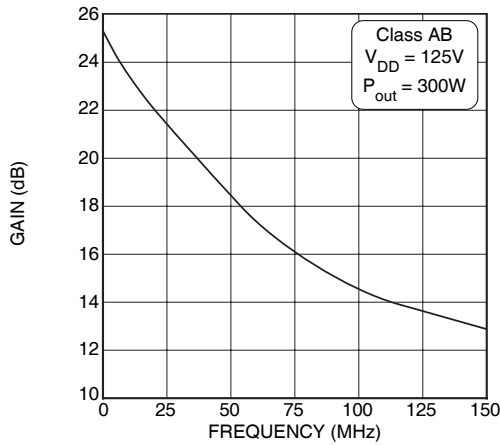

Figure 1, Typical Gain vs. Frequency

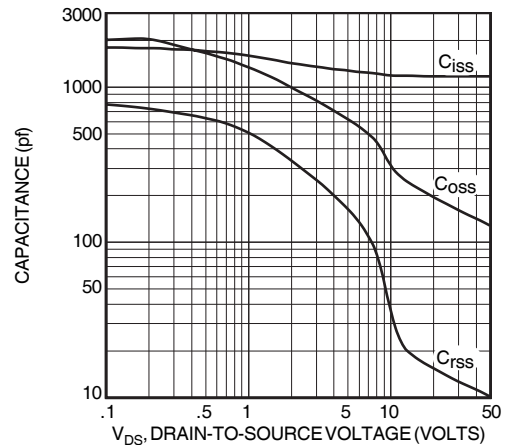

Figure 2, Typical Capacitance vs. Drain-to-Source Voltage

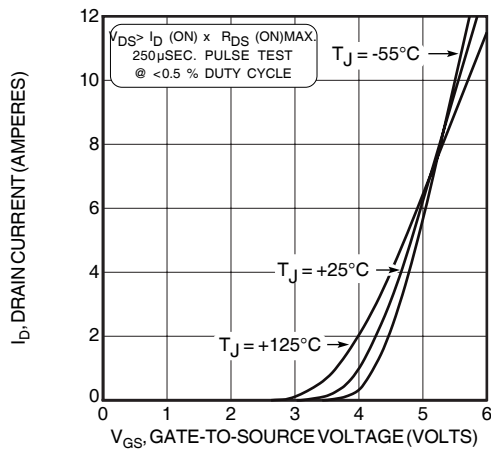

Figure 3, Typical Transfer Characteristics

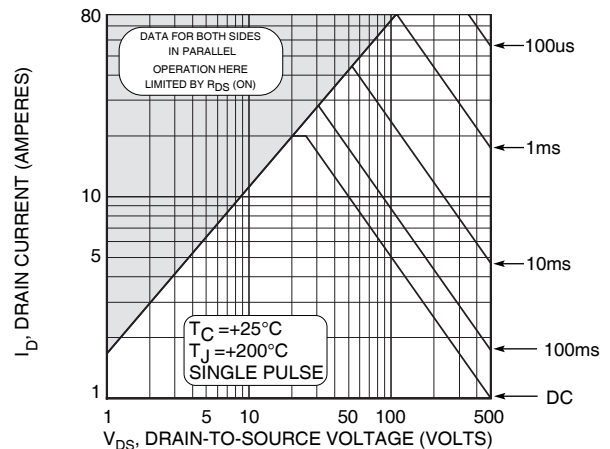

Figure 4, Typical Maximum Safe Operating Area

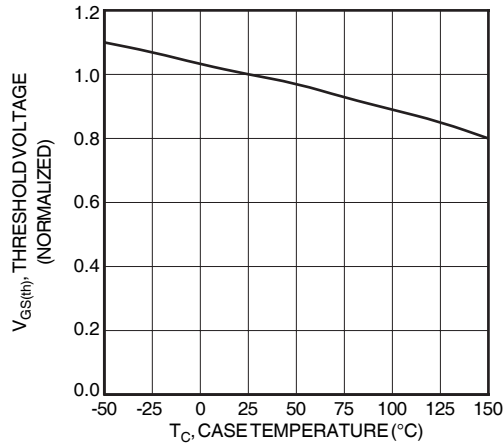

Figure 5, Typical Threshold Voltage vs Temperature

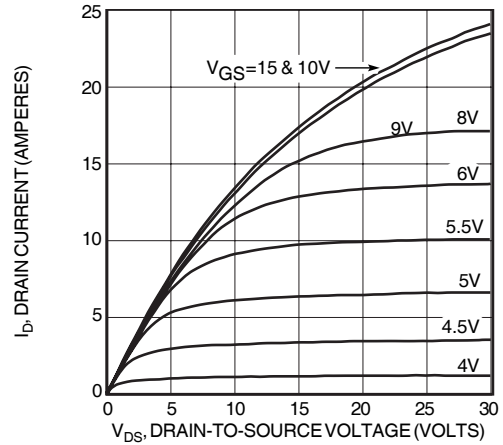

Figure 6, Typical Output Characteristics

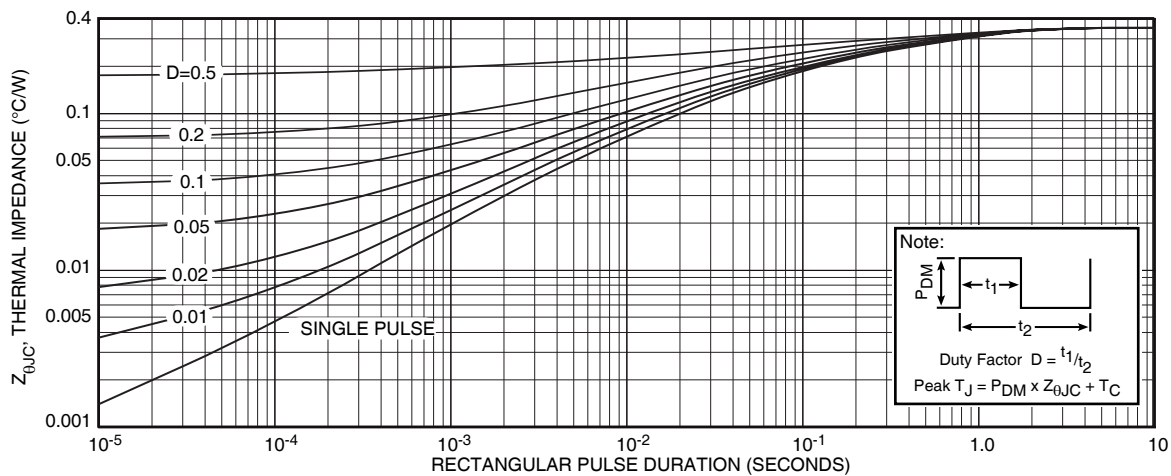
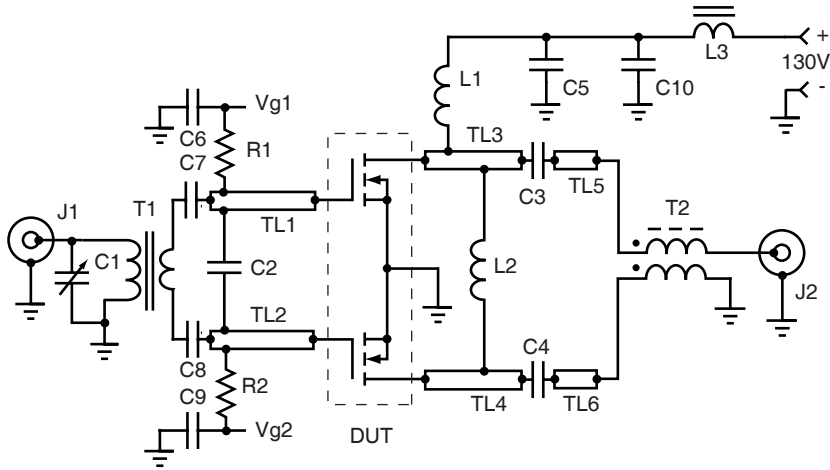

Figure 7, Maximum Effective Transient Thermal Impedance, Junction-to-Case vs. Pulse Duration

Table 1 - Typical Series Equivalent Large Signal Input - Output Impedance

Freq. (MHz)	Z _{in} (Ω)	Z _{OL} (Ω)
27.12	4.78 - j 14.3	49 - j 38.8
40.68	1.96 - j 9	33.6 - j 39.5
63.8	0.59 - j 4.1	18 - j 33.5
81.36	0.31 - j 1.65	12.3 - j 29
127.4	0.4 + j 2.66	5.5 - j 20.3

Z_{in} - Gate shunted with 100Ω I_{DQ} = 75 mA each side
 Z_{OL} - Conjugate of optimum load for 300 Watts output at V_{DD} = 125V
 Input and output impedances are measured from gate to gate and drain to drain respectively



- C1 10-80 pF trimmer ARCO 462
- C2-4 1000 pF NPO 500V chip
- C5-C9 10 nF 500V chip
- C10 .47 uF Ceramic 500V
- L1 680 nH 12t #24 enam .312" dia
- L2 55 nH 3t #18 enam .25" dia
- L3 2t #20 on Fair-Rite 2643006302 bead, ~ 2 uH
- R1-2 100 Ω 0.5 W
- T1 4:1 RF transformer on two beads same as L3.
- T2 1:1 coax balun. Fair-Rite 2643665902 bead on 1.5" RG-303 50 Ω teflon coax.
- TL1-2 Printed line L=1.2" w=.23"
- TL3-4 Printed line L=.25" w=.23"
- TL5-6 Printed line L=0.25" w=.23" 0.23" wide stripline on FR-4 board is ~32Ω Zo

Peak Output Power vs... Vdd

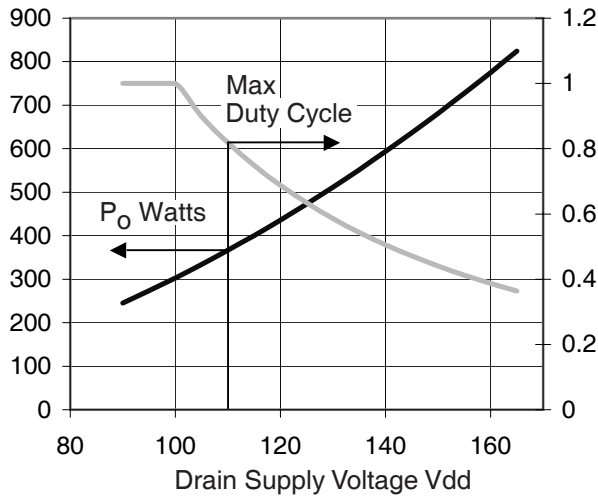

Notes:

- The value of L2 must be adjusted as the supply voltage is changed to maintain resonance in the output circuit. At 81 MHz its value changes from approximately 50 nH at 100V to 70 nH at 165V.
- The duty cycle past 100V must be reduced to insure power dissipation is within the limits of the device. Maximum pulse length should be 100mS or less. See figure 7.

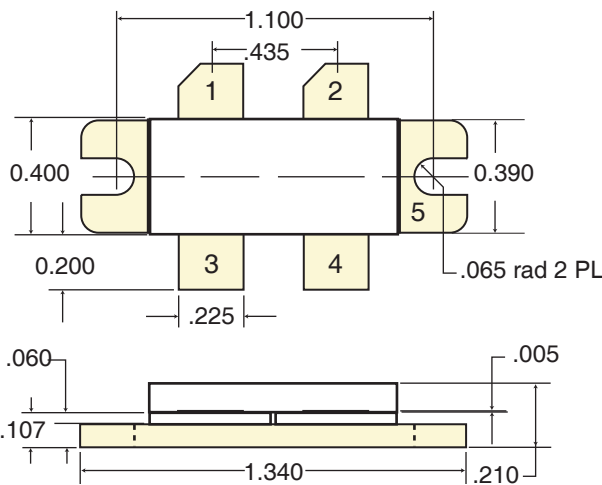

Package Dimensions (inches)

HAZARDOUS MATERIAL WARNING

□ The ceramic portion of the device between leads and mounting flange is beryllium oxide. Beryllium oxide dust is highly toxic when inhaled. Care must be taken during handling and mounting to avoid damage to this area. These devices must never be thrown away with general industrial or domestic waste.

- Pin 1. Drain
- 2. Drain
- 3. Gate
- 4. Gate
- 5. Source