

## MG200J6ES61 (600V/200A 6in1)

High Power Switching Applications

Motor Control Applications

- Integrates inverter power circuit in to a single package.
- The electrodes are isolated from case.
- Low thermal resistance
- $V_{CE(sat)} = 2.0\text{ V (typ.)}$

### Equivalent Circuit

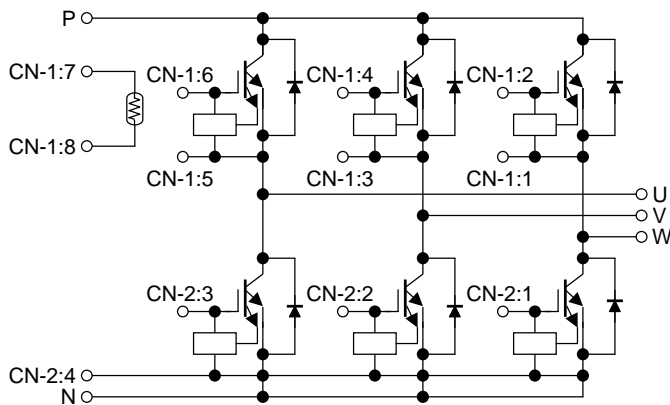

### Signal Terminal

CN-1

- |          |          |          |          |
|----------|----------|----------|----------|
| 1. E (W) | 2. G (W) | 3. E (V) | 4. G (V) |
| 5. E (U) | 6. G (U) | 7. TH1   | 8. TH2   |

CN-2

- |          |          |          |          |
|----------|----------|----------|----------|
| 1. G (Z) | 2. G (Y) | 3. G (X) | 4. E (L) |
|----------|----------|----------|----------|

## Package Dimensions:

Unit: mm

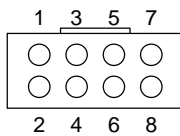
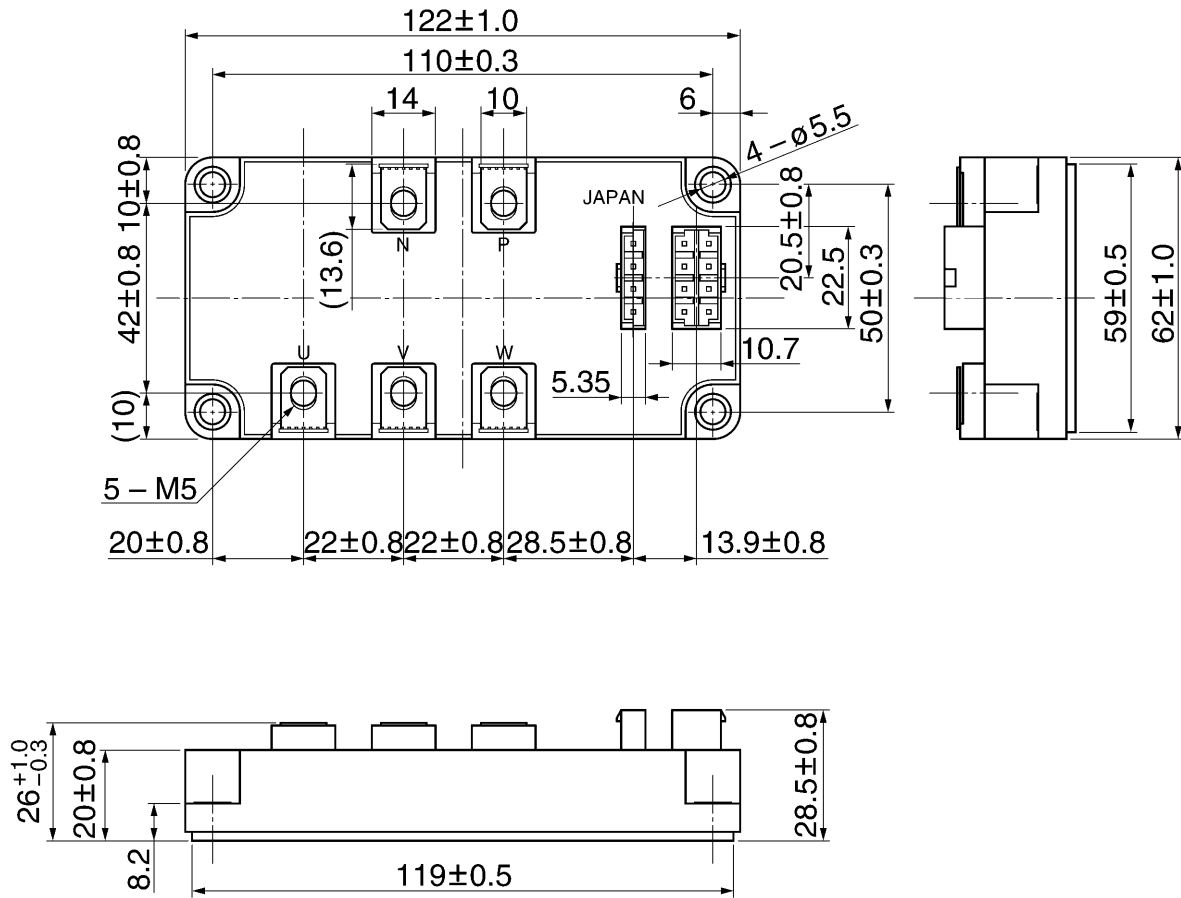

CN-1

- |          |          |          |          |
|----------|----------|----------|----------|
| 1. E (W) | 2. G (W) | 3. E (V) | 4. G (V) |
| 5. E (U) | 6. G (U) | 7. TH1   | 8. TH2   |

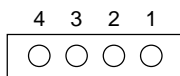

CN-2

- |          |          |          |          |
|----------|----------|----------|----------|
| 1. G (Z) | 2. G (Y) | 3. G (X) | 4. E (L) |
|----------|----------|----------|----------|

## Maximum Ratings (Ta = 25°C)

Stage	Characteristics	Symbol	Rating	Unit	
Inverter	Collector-emitter voltage	$V_{CES}$	600	V	
	Gate-emitter voltage	$V_{GES}$	±20	V	
	Collector current	DC	$I_C$	200	A
		1 ms	$I_{CP}$	400	
	Forward current	DC	$I_F$	200	A
		1 ms	$I_{FM}$	400	
Collector power dissipation (Tc = 25°C)		$P_C$	1000	W	
Module	Junction temperature	$T_j$	150	°C	
	Storage temperature range	$T_{stg}$	-40~125	°C	
	Isolation voltage	$V_{isol}$	2500 (AC 1 min)	V	
	Screw torque	—	3 (M5)	N·m	

## Electrical Characteristics (Tj = 25°C)

### 1. Inverter stage

Characteristics	Symbol	Test Condition	Min	Typ.	Max	Unit	
Gate leakage current	$I_{GES}$	$V_{GE} = \pm 20 \text{ V}, V_{CE} = 0$	—	—	±500	nA	
Collector cut-off current	$I_{CES}$	$V_{CE} = 600 \text{ V}, V_{GE} = 0$	—	—	1.0	mA	
Gate-emitter cut-off voltage	$V_{GE} \text{ (off)}$	$V_{CE} = 5 \text{ V}, I_C = 200 \text{ mA}$	5.0	6.5	8.0	V	
Collector-emitter saturation voltage	$V_{CE} \text{ (sat)}$	$V_{GE} = 15 \text{ V}, I_C = 200 \text{ A}$	$T_j = 25^\circ\text{C}$	—	2.0	2.4	V
			$T_j = 125^\circ\text{C}$	—	—	2.6	
Input capacitance	$C_{ies}$	$V_{CE} = 10 \text{ V}, V_{GE} = 0, f = 1 \text{ MHz}$	—	40000	—	pF	
Switching time	Turn-on delay time	$t_d \text{ (on)}$	—	—	1.00	μs	
	Turn-off time	$t_{off}$	—	—	1.20		
	Fall time	$t_f$	—	—	0.50		
Reverse recovery time	$t_{rr}$		—	—	0.30		
Forward voltage	$V_F$	$I_F = 200 \text{ A}$	—	2.2	2.6	V	

Note 1: Switching time test circuit & timing chart

### 2. Module (Tc = 25°C)

Characteristics	Symbol	Test Condition	Min	Typ.	Max	Unit
Zero-power resistance	R25	ITM = 0.2 mA	—	100	—	kΩ
B value	B25/85	Tc = 25°C/Tc = 85°C	—	4390	—	K
Junction to case thermal resistance	$R_{th} \text{ (j-c)}$	Inverter IGBT stage	—	—	0.125	°C/W
		Inverter FRD stage	—	—	0.195	
Case to fin thermal resistance	$R_{th} \text{ (c-f)}$	—	—	0.013	—	°C/W

## Switching Time Test Circuit & Timing Chart

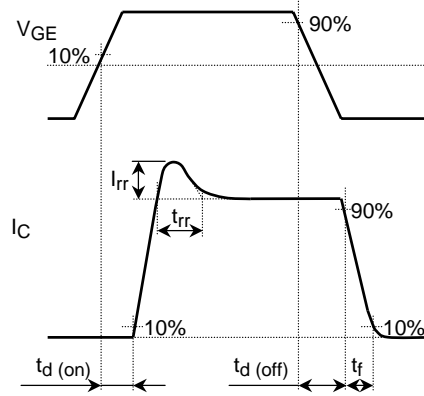
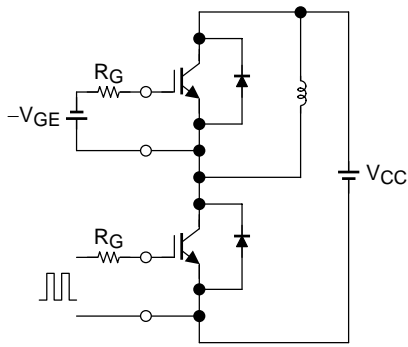

### Recommended conditions for application

Characteristics	Symbol	Min	Typ.	Max	Unit
P-N power terminal supply voltage	$V_{CC}$	—	300	400	V
Gate voltage	$V_{GE}$	13.5	15	16.5	V
Switching frequency	$f_c$	—	—	20	kHz