



The Future of Analog IC Technology®

# EV0034

## 2A, 1.3MHz Step-Up Converter

EVALUATION BOARD

### DESCRIPTION

The EV0034 is a MP1527 evaluation board configured to provide a regulated 12V output at up to 300mA from a 2.6V input or higher. The output voltage is adjustable from  $V_{IN}$  to 25V by changing resistors on the evaluation board.

The MP1527 has a high 1.3MHz switching frequency that allows for smaller external components, producing a compact solution for medium-to-high current step-up, flyback, and SEPIC applications.

### ELECTRICAL SPECIFICATIONS

Parameter	Symbol	Value	Units
Input Voltage	$V_{IN}$	2.6 – 12	V
Output Voltage	$V_{OUT}$	12	V
Output Current	$I_{OUT}$	300	mA

### FEATURES

- 2.6V Minimum Input Voltage
- 12V Output Voltage, Adjustable from  $V_{IN}$  to 25V
- Up to 90% Efficiency
- 1.3MHz Switching Frequency
- Fully Assembled and Tested

### APPLICATIONS

- SOHO Routers, PCMCIA Cards, Mini PCI
- Handheld Computers, PDAs
- Cell Phones, Digital and Video Cameras
- Small LCD Displays

"MPS" and "The Future of Analog IC Technology", are Trademarks of Monolithic Power Systems, Inc.

## EV0034 EVALUATION BOARD



(L x W x H) 2.5" x 2.0" x 0.4"  
(6.4cm x 5.0cm x 1.0cm)

Board Number	MPS IC Number
EV0034	MP1527DR

### Efficiency vs Load Current

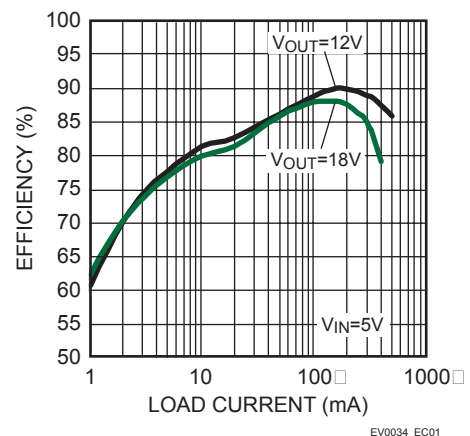

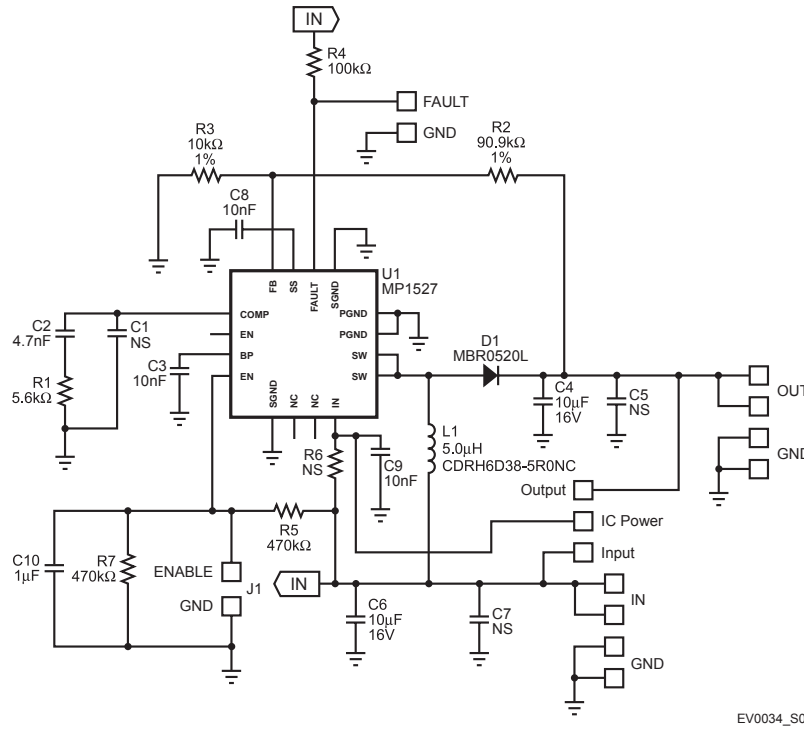
**EVALUATION BOARD SCHEMATIC**

EV0034\_S01

**EV0034 BILL OF MATERIALS**

Qty	Ref	Value	Description	Package	Manufacturer: P/N
3	C1, C5, C7		No Stuff		
1	C2	4.7nF	Ceramic Capacitor, 50V, X7R	0805	AVX: 08055C472KAT2A
3	C3, C8, C9	10nF	Ceramic Capacitor, 50V, X7R	0805	AVX: 08055C103KAT2A
2	C4, C6	10µF	Ceramic Capacitor, 16V, X5R	1210	AVX: 1210YD106KAT2A
1	C10	1µF	Ceramic Capacitor, 16V, X7R	0603	TDK: C1608X7R1C105K
1	D1		Schottky Diode, 0.5A, 20V, SOD-123	SOD-123	Fairchild: MBR0520L
1	L1	5.0µH	Inductor, 2.9A	SMD	Sumida: CDRH6D38-5R0NC
1	R1	5.6kΩ	Resistor, 5%	0805	Panasonic: ERJ-6GEYJ562V
1	R2	90.9kΩ	Resistor, 1%	0805	Panasonic: ERJ-6ENFJ9092V
1	R3	10kΩ	Resistor, 1%	0805	Panasonic: ERJ-6ENFJ1002V
1	R4	100kΩ	Resistor, 5%	0805	Panasonic: ERJ-6GEYJ104V
2	R5, R7	470kΩ	Resistor, 5%	0805	Panasonic: ERJ-6GEYJ474V
1	R6		No Stuff		
1	U1		Step-Up Converter, 2A, Fixed Frequency		MPS: MP1527DR

**PRINTED CIRCUIT BOARD LAYOUT**

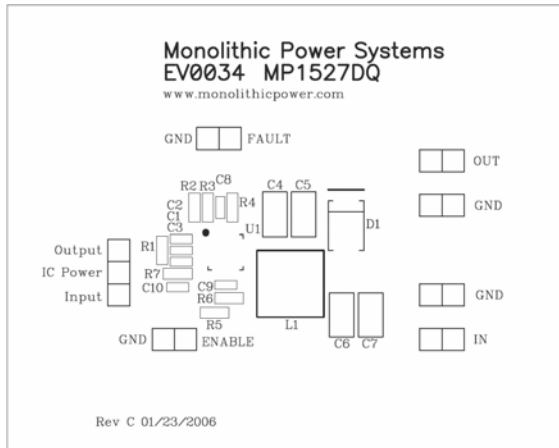

**Figure 1—Top Silk Layer**

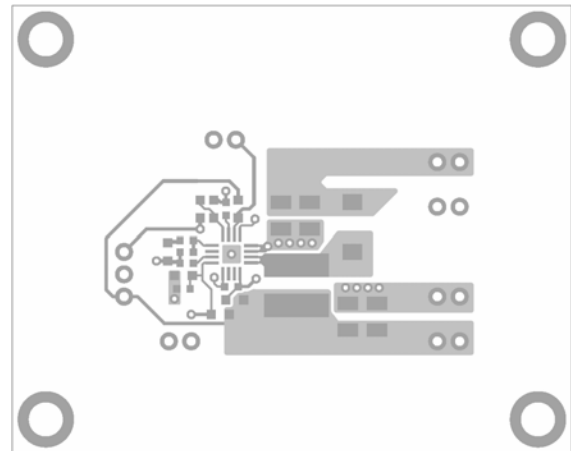

**Figure 2—Top Layer**

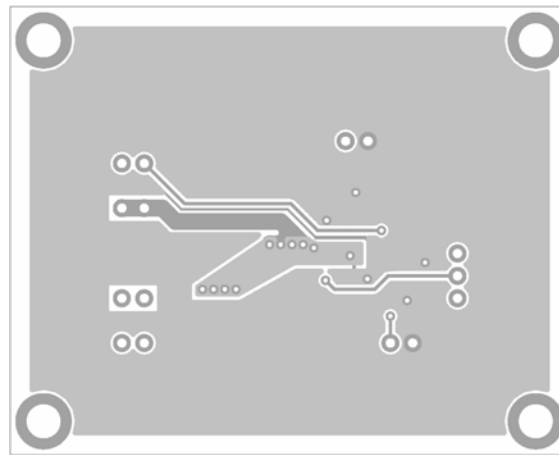

**Figure 3—Bottom Layer**

## QUICK START GUIDE

The EV0034 is configured to produce a fixed 12V output voltage from an input voltage ranging from 2.6V to 12V:

1. Connect the positive and negative terminals of the load to the OUT and GND pins, respectively.
2. Preset the power supply output to between 2.6V and 12V, then turn it off.
3. Connect the positive and negative terminals of the power supply output to the IN and GND pins, respectively.
4. Connect the IN pin of the chip to the regulator's input supply  $V_{IN}$  for bootstrapped operation (boot-strapped operation is required for  $V_{IN}$  of less than 3V) through the IC Power jumper.
5. Turn the power supply on. The board is set up for automatic startup. Shunt the ENABLE jumper to disable the circuit. EN may be driven with an external digital signal to enable/disable the circuit.
6. Connect  $V_{IN}$  to the input power source and apply a 2.6V to 12V voltage.
7. To enable the MP1527 by an external signal, connect a 0V to 2V signal to the EN input. A low voltage at EN turns off the MP1527, a high voltage turns it on.
8. The output voltage  $V_{OUT}$  can be altered by changing the value of R2. Determine the new value of R2 using the following formula:

$$R2 = R3 \times \left( \frac{V_{OUT}}{V_{FB}} - 1 \right)$$

Where  $V_{FB}=1.22V$  and R3 remains 10k $\Omega$ .

**NOTICE:** The information in this document is subject to change without notice. Please contact MPS for current specifications. Users should warrant and guarantee that third party Intellectual Property rights are not infringed upon when integrating MPS products into any application. MPS will not assume any legal responsibility for any said applications.