



Micro Commercial Components
 21201 Itasca Street Chatsworth
 CA 91311
 Phone: (818) 701-4933
 Fax: (818) 701-4939

MMBT4403

Features

- Surface Mount SOT-23 Package
- Capable of 350mWatts of Power Dissipation

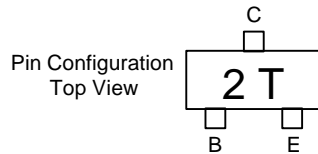

PNP General Purpose Amplifier

Electrical Characteristics @ 25°C Unless Otherwise Specified

Symbol	Parameter	Min	Max	Units
OFF CHARACTERISTICS				
$V_{(BR)CEO}$	Collector-Emitter Breakdown Voltage* ($I_C=1.0mA$, $I_E=0$)	40		Vdc
$V_{(BR)CBO}$	Collector-Base Breakdown Voltage ($I_C=100\mu A$, $I_E=0$)	40		Vdc
$V_{(BR)EBO}$	Emitter-Base Breakdown Voltage ($I_E=100\mu A$, $I_C=0$)	5.0		Vdc
I_{BL}	Base Cutoff Current ($V_{CE}=30Vdc$, $V_{BE}=3.0Vdc$)		0.1	μA
I_{CEX}	Collector Cutoff Current ($V_{CE}=30Vdc$, $V_{BE}=3.0Vdc$)		0.1	μA

ON CHARACTERISTICS

h_{FE}	DC Current Gain* ($I_C=0.1mA$, $V_{CE}=1.0Vdc$) ($I_C=1.0mA$, $V_{CE}=1.0Vdc$) ($I_C=10mA$, $V_{CE}=1.0Vdc$) ($I_C=150mA$, $V_{CE}=2.0Vdc$) ($I_C=500mA$, $V_{CE}=2.0Vdc$)	30 60 100 100 20	300	
$V_{CE(sat)}$	Collector-Emitter Saturation Voltage ($I_C=150mA$, $I_B=15mA$) ($I_C=500mA$, $I_B=50mA$)		0.4 0.75	Vdc
$V_{BE(sat)}$	Base-Emitter Saturation Voltage ($I_C=150mA$, $I_B=15mA$) ($I_C=500mA$, $I_B=50mA$)	0.75	0.95 1.30	Vdc

SMALL-SIGNAL CHARACTERISTICS

f_T	Current Gain-Bandwidth Product ($I_C=20mA$, $V_{CE}=10Vdc$, $f=100MHz$)	200		MHz
C_{cb}	Output Capacitance ($V_{CB}=10Vdc$, $I_E=0$, $f=1.0MHz$)		8.5	pF
C_{eb}	Input Capacitance ($V_{EB}=0.5Vdc$, $I_C=0$, $f=1.0MHz$)		30.0	pF

SWITCHING CHARACTERISTICS

t_d	Delay Time	($V_{CC}=3.0Vdc$, $V_{BE}=2.0Vdc$)	15	ns
t_r	Rise Time	$I_C=150mA$, $I_{B1}=15mA$	20	ns
t_s	Storage Time	($V_{CC}=3.0Vdc$, $I_C=150mA$)	225	ns
t_f	Fall Time	$I_{B1}=I_{B2}=15mA$	30	ns

*Pulse Width $\leq 300\mu s$, Duty Cycle $\leq 2.0\%$

SOT-23

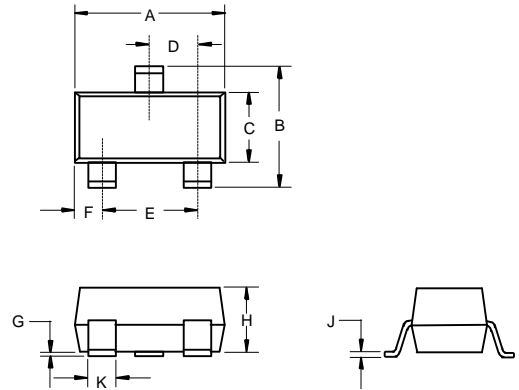

DIM	INCHES		MM		NOTE
	MIN	MAX	MIN	MAX	
A	.110	.120	2.80	3.04	
B	.083	.098	2.10	2.64	
C	.047	.055	1.20	1.40	
D	.035	.041	.89	1.03	
E	.070	.081	1.78	2.05	
F	.018	.024	.45	.60	
G	.0005	.0039	.013	.100	
H	.035	.044	.89	1.12	
J	.003	.007	.085	.180	
K	.015	.020	.37	.51	

Suggested Solder Pad Layout

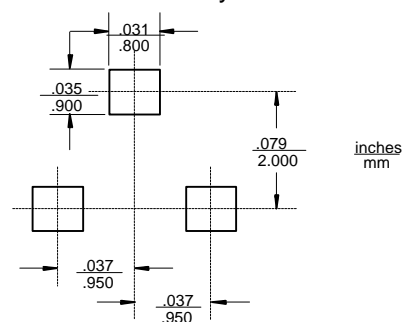

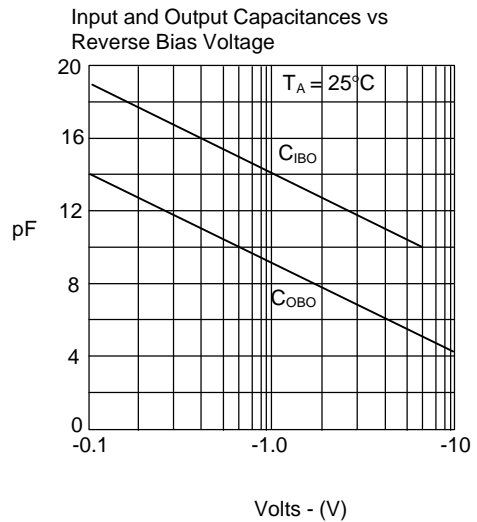
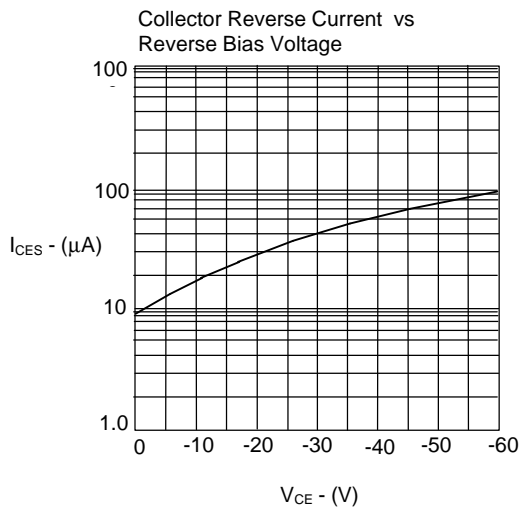
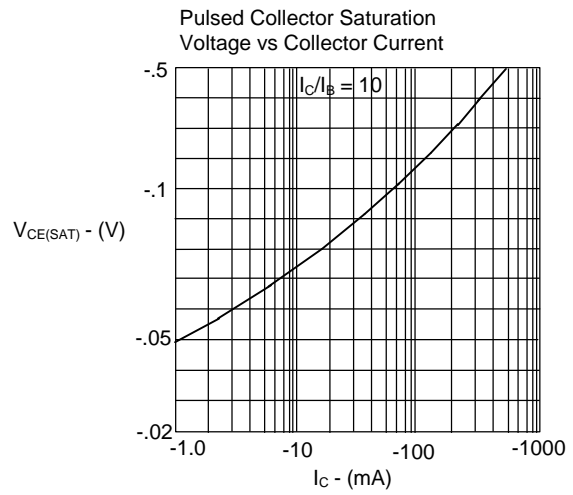
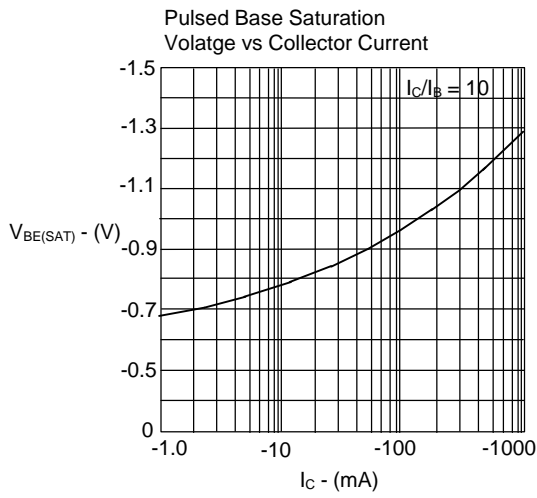
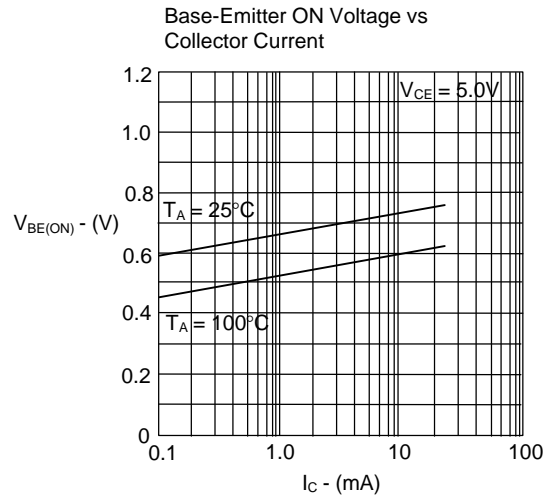
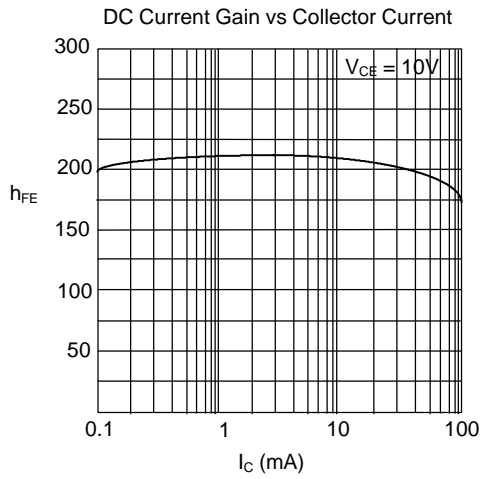

MMBT4403

