

NPN Silicon RF Transistor

- For linear broadband amplifier application up to 500 MHz
- SAW filter driver in TV tuners

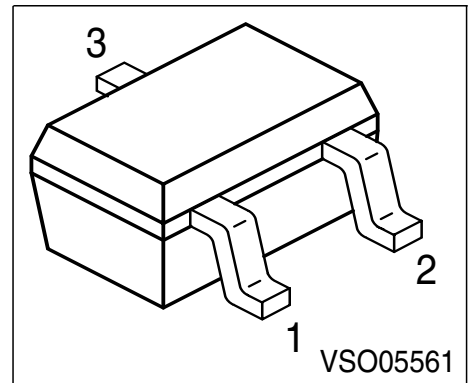

Type	Marking	Pin Configuration			Package
BF799W	LKs	1 = B	2 = E	3 = C	SOT323

Maximum Ratings

Parameter	Symbol	Value	Unit
Collector-emitter voltage	V_{CEO}	20	V
Collector-emitter voltage	V_{CES}	30	
Collector-base voltage	V_{CBO}	30	
Emitter-base voltage	V_{EBO}	3	
Collector current	I_C	35	mA
Base current	I_B	10	
Total power dissipation $T_S = 107\text{ °C}$	P_{tot}	280	mW
Junction temperature	T_j	150	°C
Storage temperature	T_{stg}	-65 ... 150	

Thermal Resistance

Junction - soldering point ¹⁾	R_{thJS}	≤ 155	K/W
--	------------	------------	-----

¹⁾For calculation of R_{thJA} please refer to Application Note Thermal Resistance

Electrical Characteristics at $T_A = 25\text{ }^\circ\text{C}$, unless otherwise specified.

Parameter	Symbol	Values			Unit
		min.	typ.	max.	
DC characteristics					
Collector-emitter breakdown voltage $I_C = 1\text{ mA}, I_B = 0$	$V_{(BR)CEO}$	20	-	-	V
Collector-base breakdown voltage $I_C = 10\text{ }\mu\text{A}, I_E = 0$	$V_{(BR)CBO}$	30	-	-	
Base-emitter breakdown voltage $I_E = 10\text{ }\mu\text{A}, I_C = 0$	$V_{(BR)EBO}$	3	-	-	
Collector-base cutoff current $V_{CB} = 20\text{ V}, I_E = 0$	I_{CBO}	-	-	100	nA
DC current gain $I_C = 5\text{ mA}, V_{CE} = 10\text{ V}$ $I_C = 20\text{ mA}, V_{CE} = 10\text{ V}$	h_{FE}	35 40	95 100	- 250	-
Collector-emitter saturation voltage $I_C = 20\text{ mA}, I_B = 2\text{ mA}$	V_{CEsat}	-	0.1	0.3	V
Base-emitter saturation voltage $I_C = 20\text{ mA}, I_B = 2\text{ mA}$	V_{BEsat}	-	-	0.95	
AC characteristics					
Transition frequency $I_C = 5\text{ mA}, V_{CE} = 10\text{ V}, f = 100\text{ MHz}$ $I_C = 20\text{ mA}, V_{CE} = 8\text{ V}, f = 100\text{ MHz}$	f_T	- -	800 1100	- -	MHz
Output capacitance $V_{CB} = 10\text{ V}, I_E = 0\text{ mA}, f = 1\text{ MHz}$	C_{ob}	-	0.96	-	pF
Collector-base capacitance $V_{CB} = 10\text{ V}, f = 1\text{ MHz}$	C_{cb}	-	0.7	-	
Collector-emitter capacitance $V_{CE} = 10\text{ V}, f = 1\text{ MHz}$	C_{ce}	-	0.28	-	
Noise figure $I_C = 5\text{ mA}, V_{CE} = 10\text{ V}, f = 100\text{ MHz},$ $Z_S = 50\text{ }\Omega$	F	-	3	-	dB
Output conductance $I_C = 20\text{ mA}, V_{CE} = 10\text{ V}, f = 35\text{ MHz}$	g_{22e}	-	60	-	μS

Total power dissipation $P_{tot} = f(T_S)$

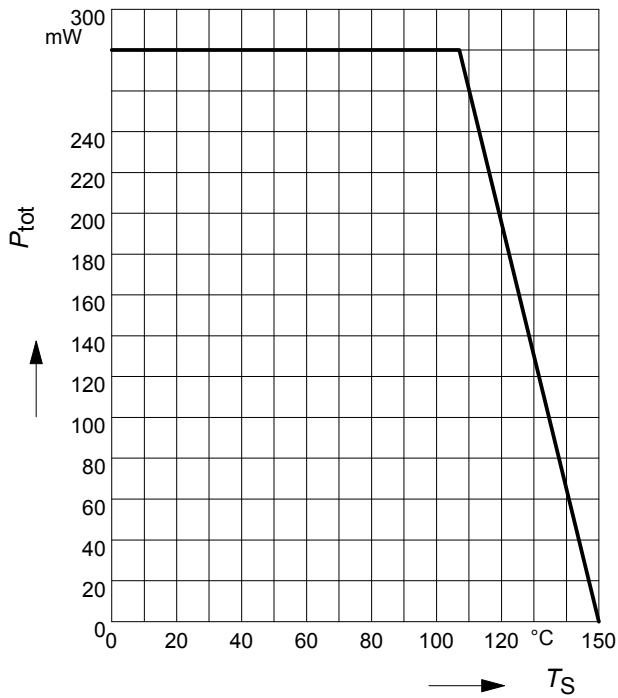

Permissible Pulse Load $R_{thJS} = f(t_p)$

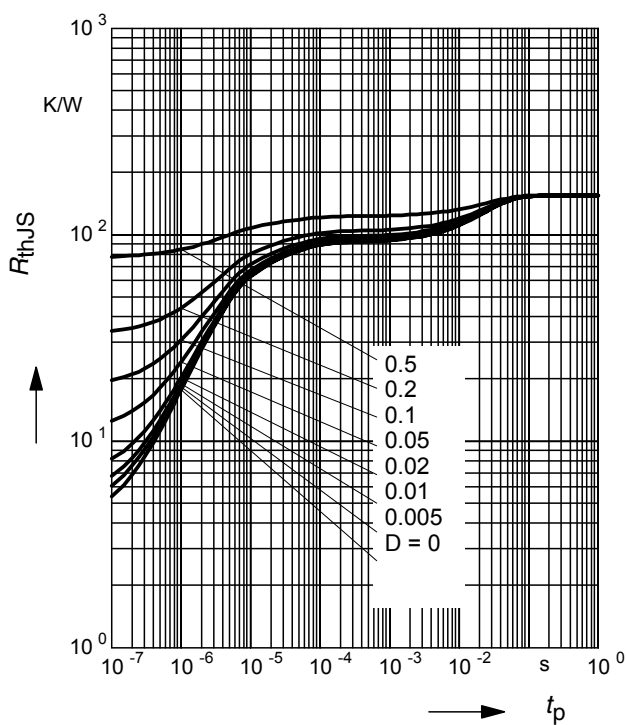

Permissible Pulse Load

$P_{totmax} / P_{totDC} = f(t_p)$

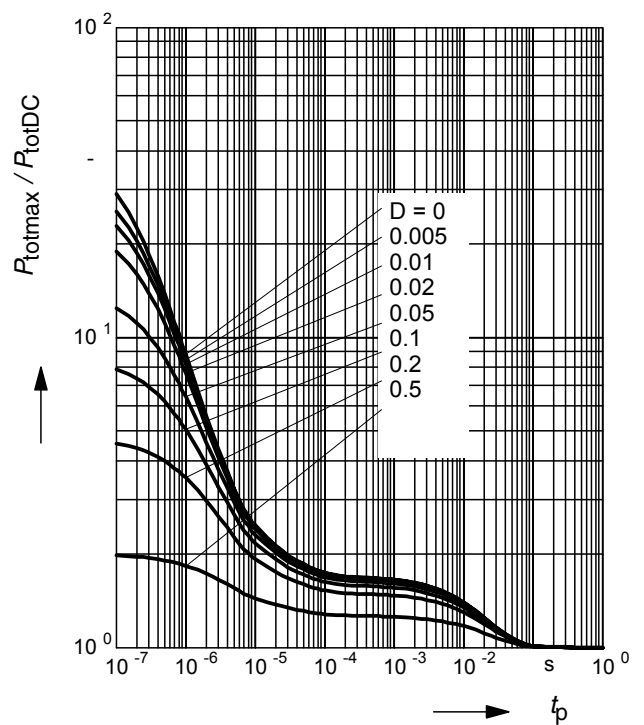

Transition frequency $f_T = f(I_C)$

$f = 100\text{MHz}$

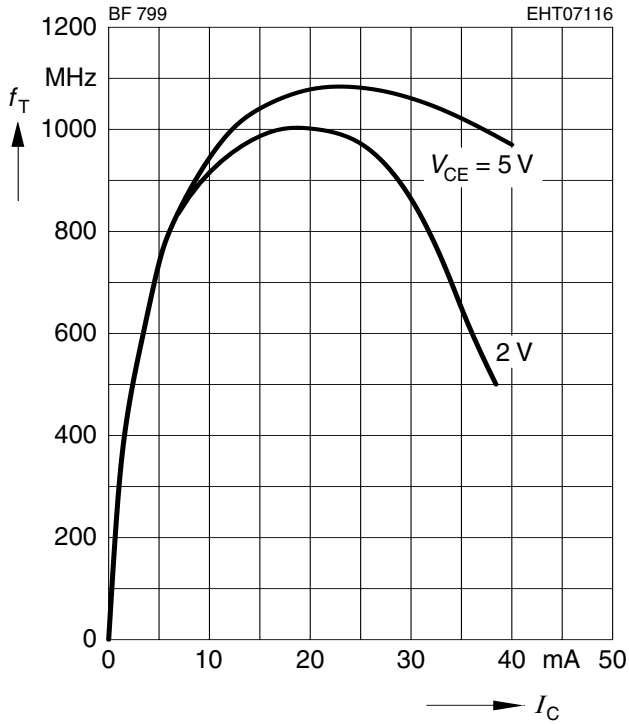

Collector-base capacitance $C_{cb} = f(V_{CB})$

$f = 1\text{ MHz}$

