

# TB62736FUG

## Step-up Type DC-DC Converter for White LEDs

The TB62736FUG is a high efficiency step-up type DC/DC converter that is designed especially for use as a constant current driver of white LEDs.

It is possible to drive 2 - 6 white LEDs connected in series using a lithium-ion battery. (Typ. 4 White LEDs)

This IC incorporates an N-ch-MOS transistor required for switching of an external inductor.

The forward current of the LEDs can be controlled by an external resistor. An analog voltage input and a pulse input system (PWM) can be used as a brightness control function.

The switching frequency is fixed at around 1.1 MHz.

This IC is best suited for use as a driver of white LED back lighting in color LCDs in PDAs, cellular phones and handy terminal devices.

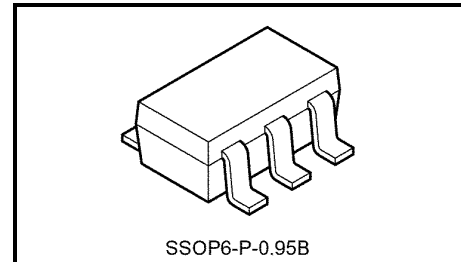

SSOP6-P-0.95B

Weight: 0.016 g (typ.)

### Features

- Brightness control function : LED forward current 25~100%
- Maximum output voltage : over 24V
- LED current values controlled by external resistance : 20mA (typ.) @ RSENS=16Ω
- Output power : 400 mW
- Package : SSOP6-P-0.95 (SOT23-6)
- High efficiency : maximum 87% (when used with components as recommended herein)
- Thermal Shutdown Function incorporated : 150 degree (typ.)

### Pin Assignment (top view)

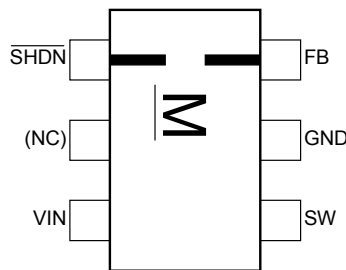

Note 1: The IC may break if mounted 180 degrees in reverse. Ensure the device is correctly orientated before assembly.

Note 2: The control pin must be set to a certain logic level, as unstable output could result if the pin is left open..

Note 3: Regarding soldering, the following conditions were confirmed

- (1) Use of Sn-63Pd solder bath  
solder bath temperature = 230°C, dipping time = 5 seconds, number of times = once, use of R-type flux
- (2) Use of Sn-3.0Ag-0.5Cu solder bath  
solder bath temperature = 245°C, dipping time = 5 seconds, number of times = once, use of R-type flux

## Block Diagram

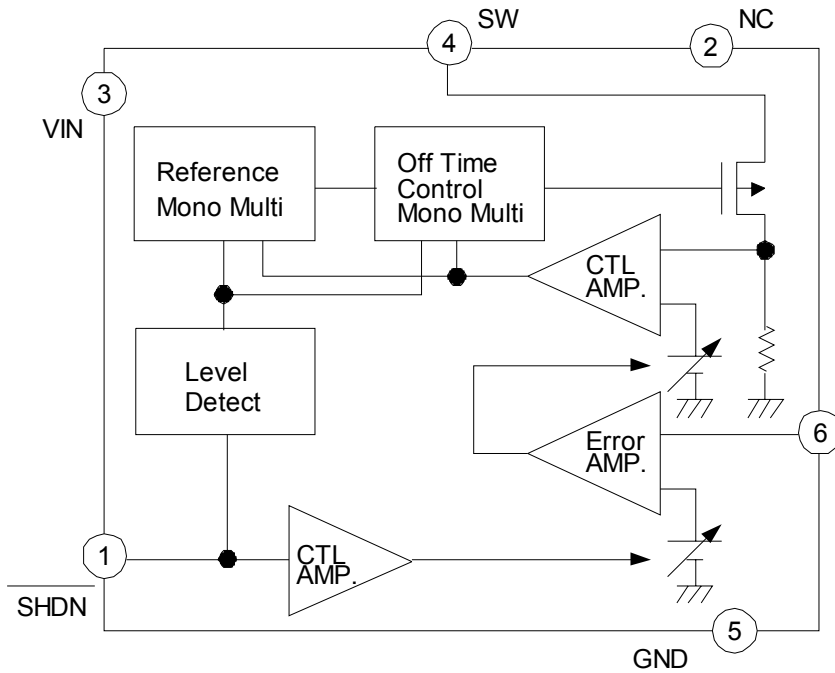

## Pin Functions

No.	Symbol	Function
1	SHDN	Input pin for IC ON/OFF control and variable LED $I_F$ . 0 to 0.5V : Shutdown Mode (IC shutdown) 1.0V to 2.5V : $I_F = 25$ to 100% Variable (Linear Control) Over 2.5V : $I_F = 100\%$ PWM signal input for IF control (see p.5)
2	NC	No Connection or Connected to GND
3	VIN	Supply voltage pin. Supply voltage range : 2.8V to 5.5V
4	SW	DC-DC converter switching pin – switch incorporates N-ch MOSFET
5	GND	Ground pin
6	FB	Connected to the cathode of LED

Note: The NC terminal is not connected to the internal circuit.

## Absolute Maximum Ratings ( $T_{opr} = 25^{\circ}\text{C}$ , unless otherwise specified)

Characteristics	Symbol	Ratings	Unit
Power supply voltage	$V_{IN}$	-0.3 to 6.0	V
Input voltage	$V_{in}$	-0.3 to $V_{CC} + 0.3$	V
Switching pin voltage	$V_O (SW)$	-0.3 to 24	V
Switching pin current	$I_O (SW)$	380	mA
Power Dissipation	$P_D$	0.41 (IC only)	W
		0.47 (IC mounted on PCB) (Note)	
Thermal resistance	$R_{th} (j-a) 1$	300 (IC only)	$^{\circ}\text{C/W}$
	$R_{th} (j-a) 2$	260 (IC mounted on PCB)	
Operating temperature range	$T_{opr}$	-40 to 85	$^{\circ}\text{C}$
Storage temperature	$T_{stg}$	-40 to 150	$^{\circ}\text{C}$
Maximum junction temperature	$T_j$	125	$^{\circ}\text{C}$

Note: Power dissipation is reduced by 3.8mW/ $^{\circ}\text{C}$  from the maximum rating for every 1 $^{\circ}\text{C}$  exceeding the ambient temperature of 25 $^{\circ}\text{C}$  (when the IC is mounted on a PCB).

## Recommended Operating Condition ( $T_{opr} = -40$ to $85^{\circ}\text{C}$ , unless otherwise specified)

Characteristics	Symbol	Test Conditions	Min.	Typ.	Max.	Unit
Power supply voltage	$V_{IN}$	—	2.8	—	5.5	V
$\overline{\text{SHDN}}$ pin H level input voltage	$V_{\overline{\text{SHDN}}} (H)$	—	2.7	—	$V_{IN}$	V
$\overline{\text{SHDN}}$ pin L level input voltage	$V_{\overline{\text{SHDN}}} (L)$	—	0	—	0.5	V
$\overline{\text{SHDN}}$ pin input pulse width	tpw	ON/OFF duty width	33	—	—	$\mu\text{s}$
LED current (Average value)	$I_{O1}$	$V_{IN} = 3.6\text{ V}$ , $R_{SENS} = 16\ \Omega$ 4LEDs, $T_{opr} = 25^{\circ}\text{C}$	—	20	—	mA

## Electrical Characteristics ( $T_{opr} = -40$ ~ $85^{\circ}\text{C}$ $V_{CC} = 2.8$ ~ $5.5\text{ V}$ , unless otherwise specified)

Characteristics	Symbol	Test Conditions	Min.	Typ.	Max.	Unit
Operating consumption current	$I_{IN} (ON)$	$V_{IN} = 6.0\text{ V}$ , $R_{SENS} = 16\ \Omega$	—	0.9	1.5	mA
Standby consumption current	$I_{IN} (OFF)$	$V_{IN} = 3.6\text{ V}$ , $V_{\overline{\text{SHDN}}} = 0\text{ V}$	—	0.5	1.0	$\mu\text{A}$
$\overline{\text{SHDN}}$ pin current	$I_{\overline{\text{SHDN}}}$	$V_{IN} = 3.6\text{ V}$ , $V_{\overline{\text{SHDN}}} = 3.6\text{ V}$	-10	0	10	$\mu\text{A}$
Integrated MOS-FET switching frequency	$f_{OSC}$	$V_{IN} = 3.6\text{ V}$ , $V_{\overline{\text{SHDN}}} = 3.6\text{ V}$	0.77	1.1	1.43	MHz
Switching pin protection voltage	$V_O (SW)$	—	—	25	—	V
Switching pin current	$I_O (SW)$	—	—	400	—	mA
Switching pin leakage current	$I_{OZ} (SW)$	—	—	0.5	1	$\mu\text{A}$
FB pin feedback voltage	$V_{FB}$	$V_{IN} = 3.6\text{ V}$ , $R_{SENS} = 16\ \Omega$ $T_{opr} = 25^{\circ}\text{C}$ , $L = 4.7\ \mu\text{H}$	308	325	342	mV
FB pin line regulation	$\Delta V_{FB}$	$V_{IN} = 3.6\text{ V}$ center $V_{IN} = 3.0\text{ V}$ to $5.0\text{ V}$	-5	—	5	%

**Application Circuit Example**

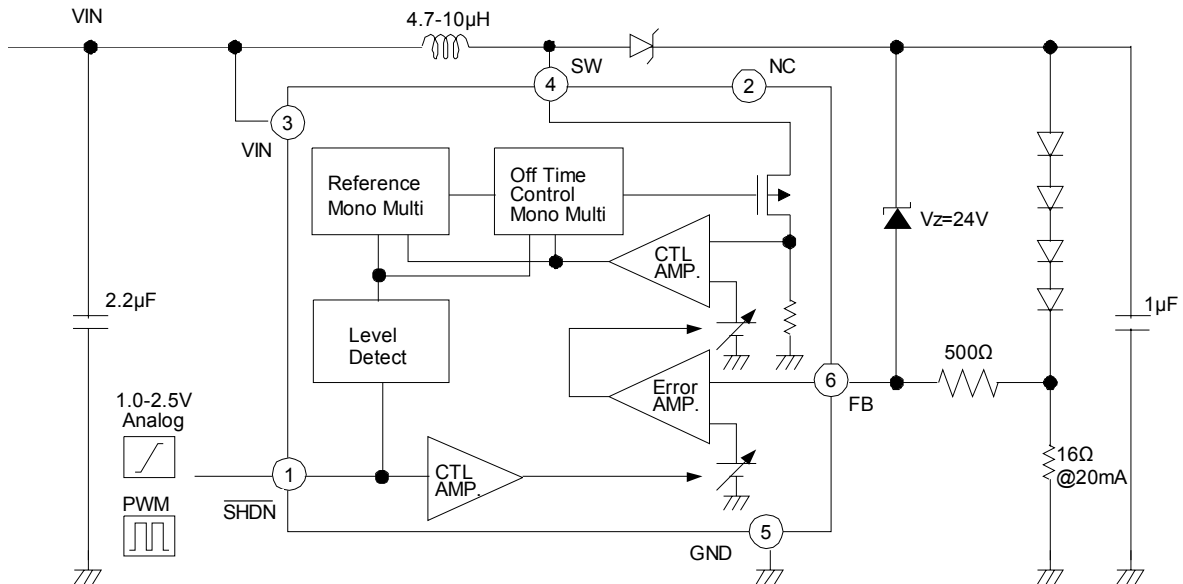

**Protection at the time of LED opening**

The zener diode in the application circuit example is necessary for the provision of over-voltage protection for when the LED becomes open. As the IC does not incorporate a voltage protection circuit, it is strongly advised that a zener diode be connected.

The zener diode should satisfy the following conditions:

- i) Less than maximum output voltage of 24V
- ii) Greater than the total series LED Vf
- iii) Less than the maximum output capacitance C<sub>2</sub>.

Moreover, by connecting a protection circuit such as R\_ZD in the figure below, it is possible to control the output current when the LED becomes open, and to use a zener diode of lower tolerance.

An example of IZD control by R\_ZD connection. (RSENS = 16 Ω)

R_DZ (Ω)	IZD (mA)
500	0.6
100	1.0

In order to avoid adverse effects on driver characteristics, Toshiba recommends a resistance of 500 ohms or less.

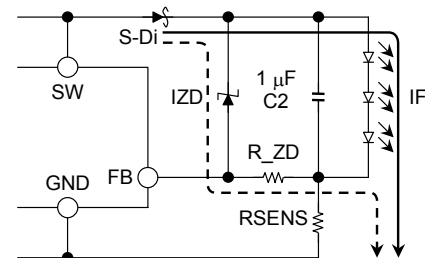

**Protection circuit application**

## Output-side Capacitor Setting

It is recommended that the value of C2 be equal to, or greater than 1.0 (μF).

## External Inductor Size Setting

For each number of LEDs, the selected inductance should be greater than the value indicated in the table below.

Number of LEDs	Inductance (Unit: μH)	Note
2	4.7	I <sub>F</sub> = 20 mA
3	6.8	
4		
5	10	
6		

## Control of I<sub>F</sub>

The resistance R<sub>SENS</sub> is connected between the FB pin and the GND pin.

The average current is controlled by the R<sub>SENS</sub> value, and calculated using the following equation:

$$I_F \text{ (mA)} = [ 325\text{mV} / R_{\text{SENS}}(\Omega) ]$$

Margin of error is ±5%.

## Current control using SHDN pin

This IC can carry out variable of the I<sub>F</sub> current by external resistance Variable range : 30 to 100%

SHDN Voltage	VSHDN=0V~0.5V	VSHDN=1V~2.5V	VSHDN>2.5V	Note
I <sub>o</sub> Valuable Rate	0	25 - 100	100	UNIT : %

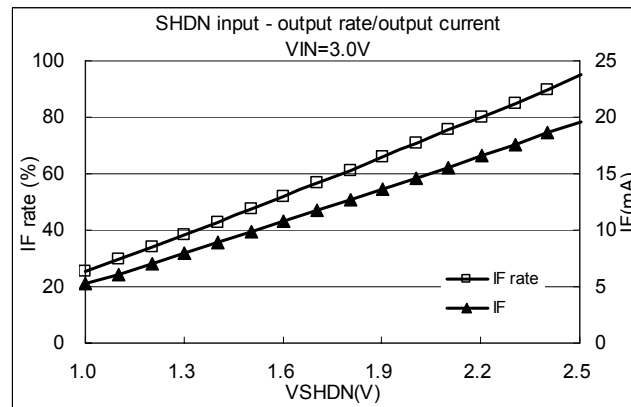

## Dimming using PWM signal input

A dimming function can also be applied using a PWM signal.

[Notes]

- When using a PWM signal, the minimum pulse width of the PWM should be greater than 33μs.
- Duty ratio of PWM function should be set at 10% - 90%.
- The recommended PWM frequency should be 100Hz - 10kHz.

<<Output current is calculated using the following equation>>

$$I_F(\text{mA}) = \frac{325[\text{mV}] \times \text{ON Duty} [\%]}{R_{\text{SENS}} [\Omega]}$$

## I/O Equivalent Pin Circuits

1.  $\overline{\text{SHDN}}$  pin

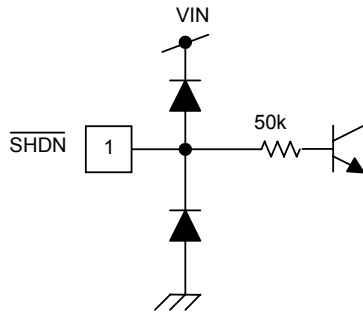

2. NC pin

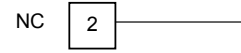

The NC pin is not connected to any internal circuit.

3. SW pin

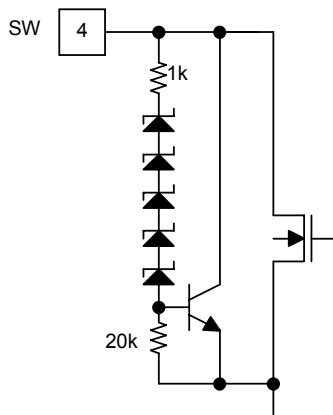

4. FB pin

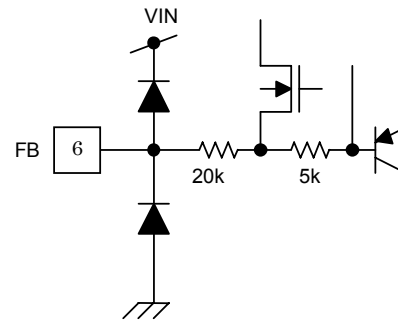

## 1. Application Circuit Example and Measurement Data (Reference data)

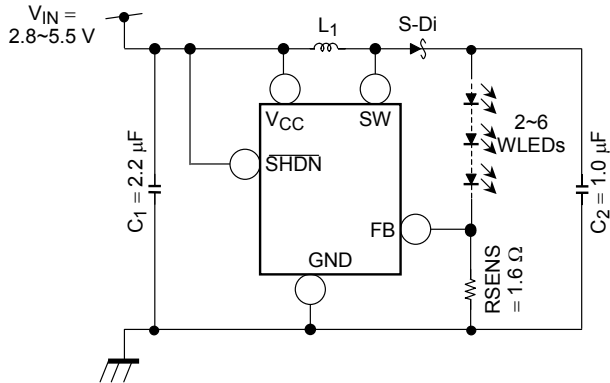

### • Evaluation conditions

- L : CXLD120 series (NEO MAX CO.,Ltd.)  
(Size 2.5 × 3.0 × 1.2 mm)
- S-Di : CUS02 1 A/30 V (TOSHIBA Corp.)
- LED : NSCW215T (NICHIA Corp.)
- C1 : C2012JB1E105K (TDK Corp.)
- C2 : C2012JB1E105K (TDK Corp.)

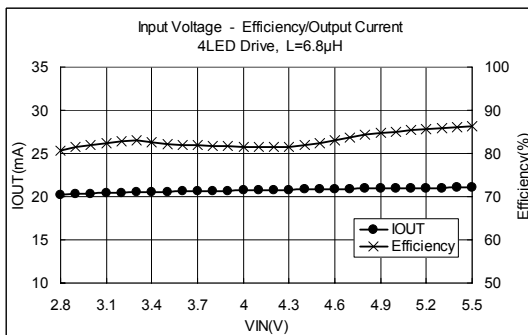
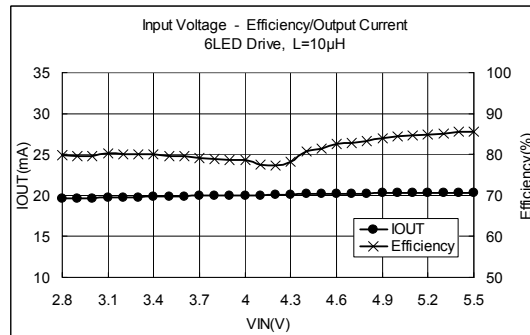
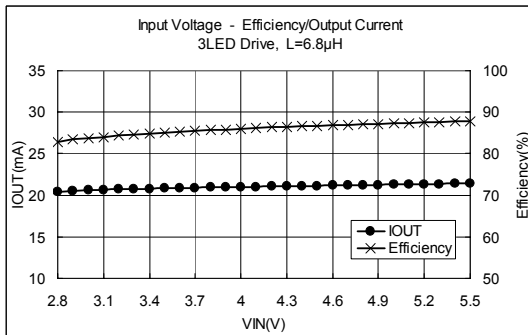
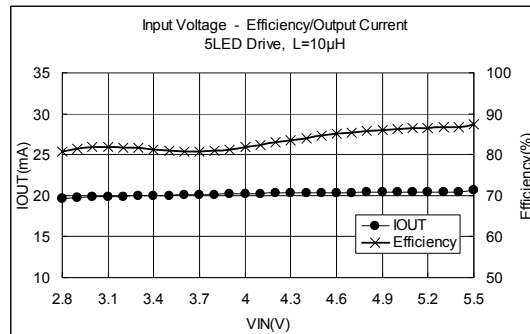
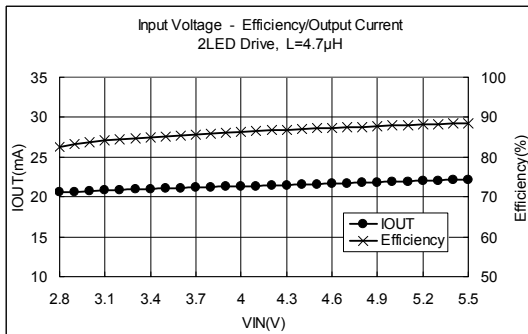

### <Measurement Data>

Efficiency in the range of  $V_{IN} = 2.8$  to  $5.5$  V

	Efficiency (%)	Average Efficiency (%)
2 LED	82.60 to 88.46	86.29
3 LED	82.69 to 87.78	85.95
4 LED	80.73 to 86.22	83.05
5 LED	80.73 to 87.28	83.45
6 LED	79.78 to 85.55	81.15

Output current in the range of  $V_{IN} = 3.0$  to  $5.0$  V

	Output Current (mA) $V_{IN} = 3.6$ V center	Tolerance (%)	
		MIN	MAX
2 LED	21.13	-3.50	1.77
3 LED	20.60	-1.95	1.38
4 LED	20.87	-1.75	1.11
5 LED	20.06	-1.81	1.15
6 LED	19.90	-1.95	1.28

## 2. Application Circuit Example and Measurement Data (Reference data)

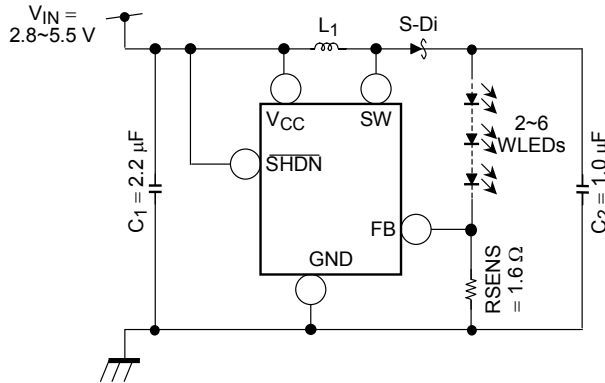

- Evaluation conditions
  - L : 1001AS series (TOKO, INC)  
(Size 3.6 × 3.6 × 1.2 mm)
  - S-Di : CUS02 1 A/30 V (TOSHIBA Corp.)
  - LED : NSCW215T (NICHIA Corp.)
  - C1 : C2012JB1E105K (TDK Corp.)
  - C2 : C2012JB1E105K (TDK Corp.)

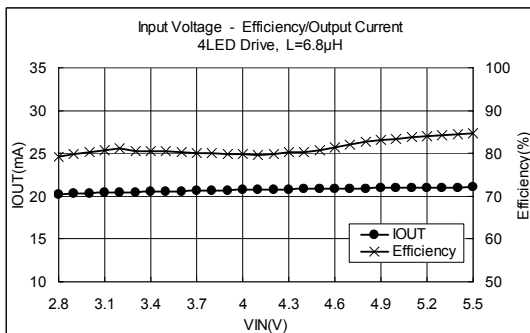
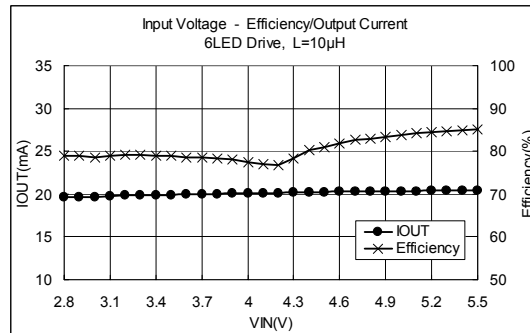
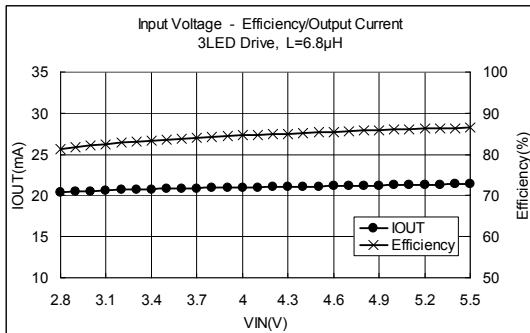
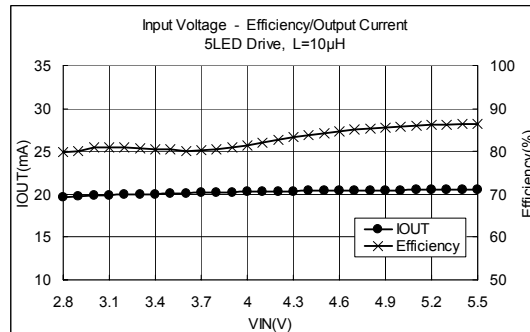
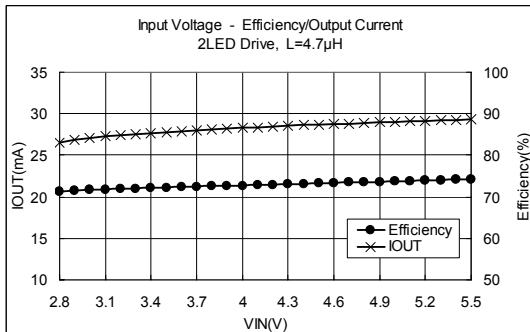

### <Measurement Data>

Efficiency in the range of  $V_{IN} = 2.8$  to  $5.5$  V

	Efficiency (%)	Average Efficiency (%)
2 LED	83.10 to 88.60	86.55
3 LED	81.32 to 86.47	84.54
4 LED	79.15 to 84.63	81.30
5 LED	79.72 to 86.39	82.87
6 LED	78.91 to 85.10	80.47

Output current in the range of  $V_{IN} = 3.0$  to  $5.0$  V

	Output Current (mA) $V_{IN} = 3.6$ V center	Tolerance (%)	
		MIN	MAX
2 LED	21.17	-3.32	1.73
3 LED	20.85	-1.95	1.38
4 LED	20.56	-1.79	1.15
5 LED	20.10	-1.82	1.22
6 LED	19.95	-1.94	1.26



### 3. Application Circuit Example and Measurement Data (Reference data)

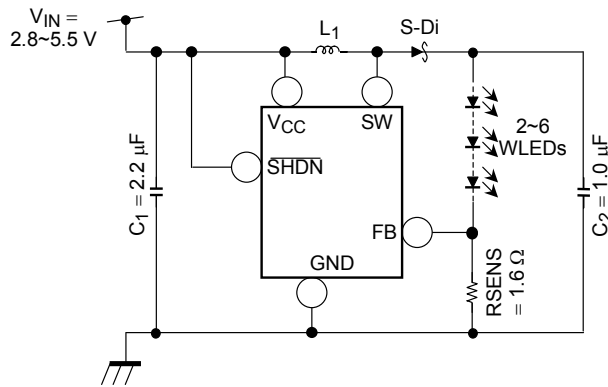

• Evaluation conditions

- L : LQH2M series (Murata Manufacturing Co.,Ltd.)  
(Size 2.0 × 1.6 × 0.95 mm)
- S-Di : CUS02 1 A/30 V (TOSHIBA Corp.)
- LED : NSCW215T (NICHIA Corp.)
- C1 : C2012JB1E105K (TDK Corp.)
- C2 : C2012JB1E105K (TDK Corp.)

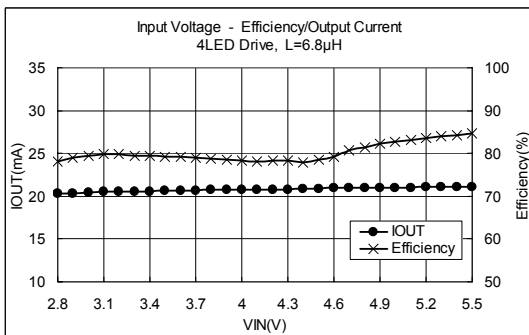
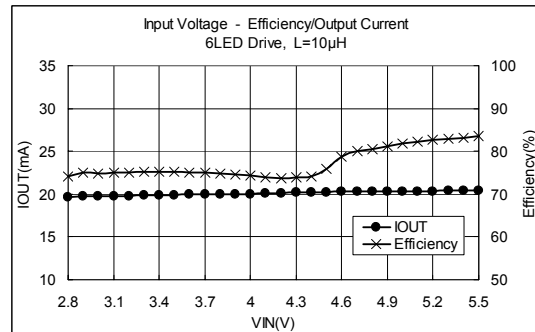
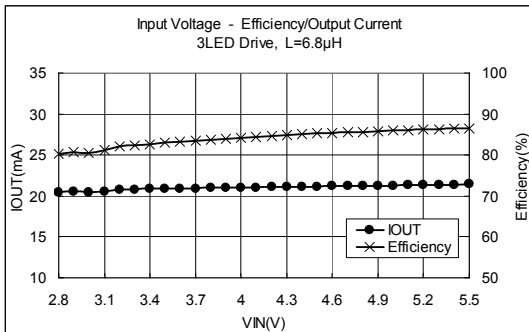
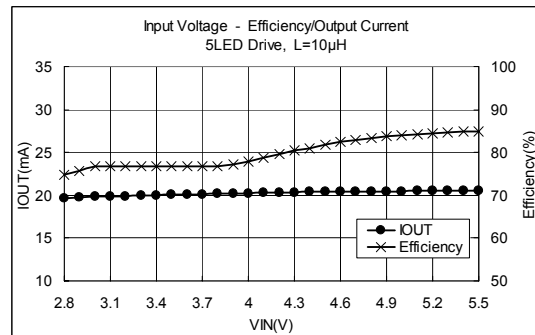
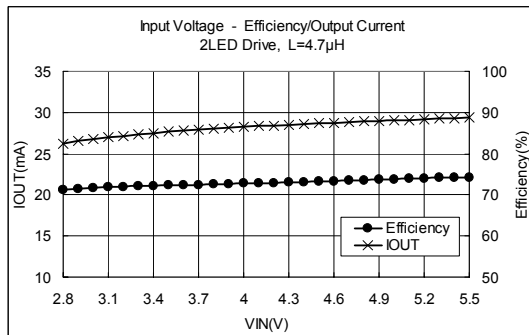

#### <Measurement Data>

Efficiency in the range of  $V_{IN} = 2.8$  to  $5.5$  V

	Efficiency (%)	Average Efficiency (%)
2 LED	82.37 to 88.70	86.38
3 LED	80.19 to 86.55	84.12
4 LED	78.11 to 84.54	80.16
5 LED	74.79 to 84.94	79.94
6 LED	74.14 to 83.47	77.17

Output current in the range of  $V_{IN} = 3.0$  to  $5.0$  V

	Output Current (mA) $V_{IN} = 3.6$ V center	Tolerance (%)	
		MIN	MAX
2 LED	21.19	-3.26	1.69
3 LED	20.90	-1.87	2.17
4 LED	20.63	-1.78	1.01
5 LED	20.09	-1.88	1.25
6 LED	19.93	-1.99	1.07

## 4. Application Circuit Example and Measurement Data (Reference data)

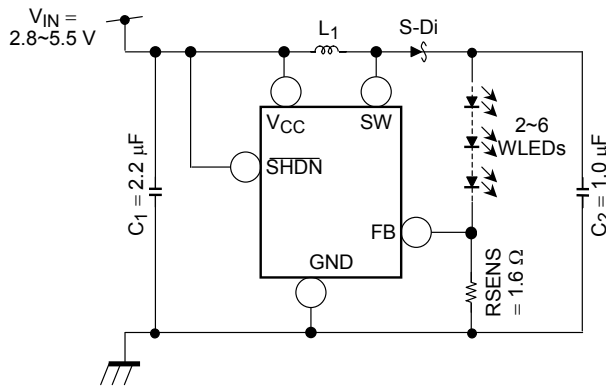

• Evaluation conditions

- L : VLF3010A series (TDK Corp.)  
(Size 3.0 × 3.0 × 1.0 mm)
- S-Di : CUS02 1 A/30 V (TOSHIBA Corp.)
- LED : NSCW215T (NICHIA Corp.)
- C1 : C2012JB1E105K (TDK Corp.)
- C2 : C2012JB1E105K (TDK Corp.)

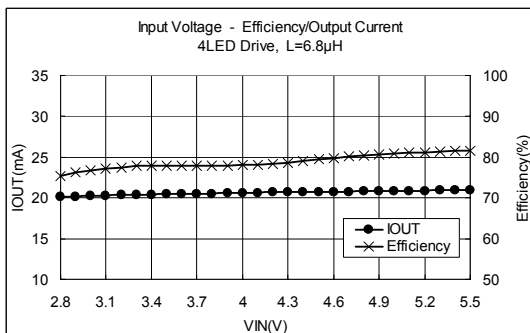
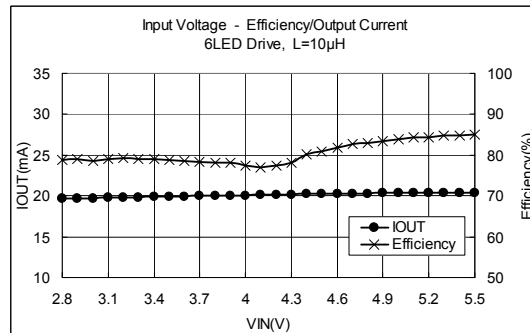
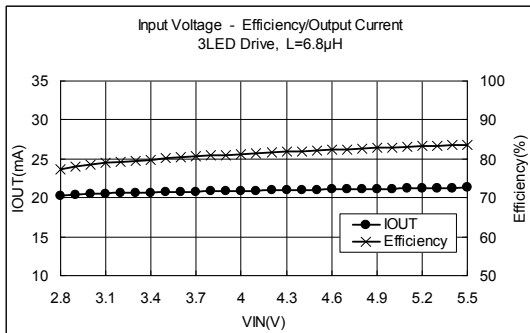
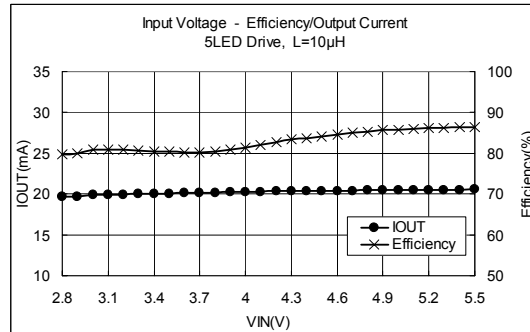
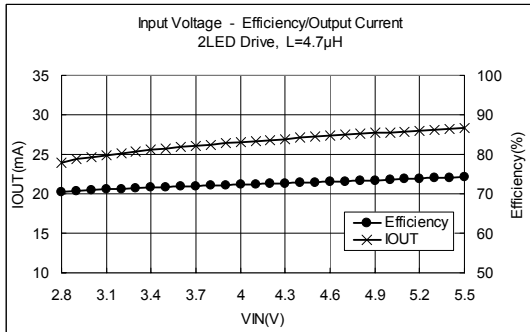

### <Measurement Data>

Efficiency in the range of  $V_{IN} = 2.8$  to  $5.5$  V

	Efficiency (%)	Average Efficiency (%)
2 LED	79.85~86.97	84.02
3 LED	80.19~85.32	83.39
4 LED	78.77~83.60	80.69
5 LED	79.72~86.39	82.87
6 LED	78.91~85.10	80.49

Output current in the range of  $V_{IN} = 3.0$  to  $5.0$  V

	Output Current (mA) $V_{IN} = 3.6$ V center	Tolerance (%)	
		MIN	MAX
2 LED	21.19	-3.08	1.67
3 LED	20.89	-1.86	1.33
4 LED	20.64	-1.68	1.11
5 LED	20.10	-1.82	1.22
6 LED	19.95	-1.94	1.26

## 5. Application Circuit Example and Measurement Data (Reference data)

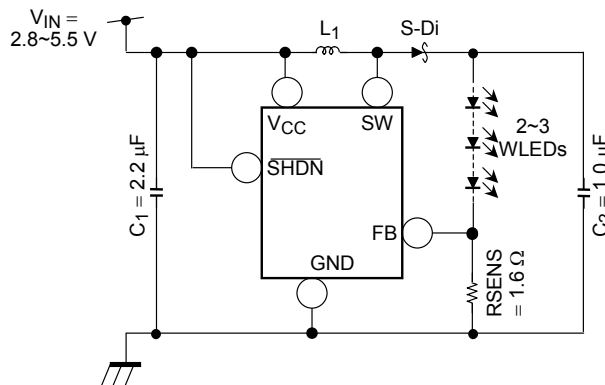

- Evaluation conditions
- L : 32R51 (KOA Corp.)  
(Size 3.2 × 2.5 × 0.6 mm)
- S-Di : CUS02 1 A/30 V (TOSHIBA Corp.)
- LED : NSCW215T (NICHIA Corp.)
- C1 : C2012JB1E105K (TDK Corp.)
- C2 : C2012JB1E105K (TDK Corp.)

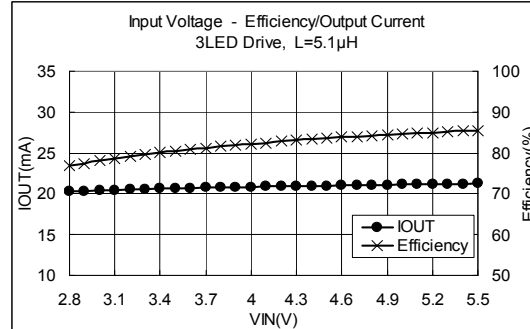
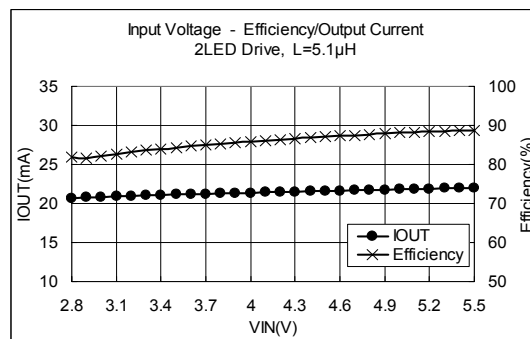

### <Measurement Data>

Efficiency in the range of V<sub>IN</sub> = 2.8 to 5.5 V

	Efficiency (%)	Average Efficiency (%)
2 LED	81.78~88.79	85.84
3 LED	76.84~85.48	82.17

Output current in the range of V<sub>IN</sub> = 3.0 to 5.0 V

	Output Current (mA) V <sub>IN</sub> = 3.6 V center	Tolerance (%)	
		MIN	MAX
2 LED	21.19	-2.99	1.64
3 LED	20.71	-1.98	1.44

## Package Dimensions

SSOP6-P-0.95B

Unit: mm

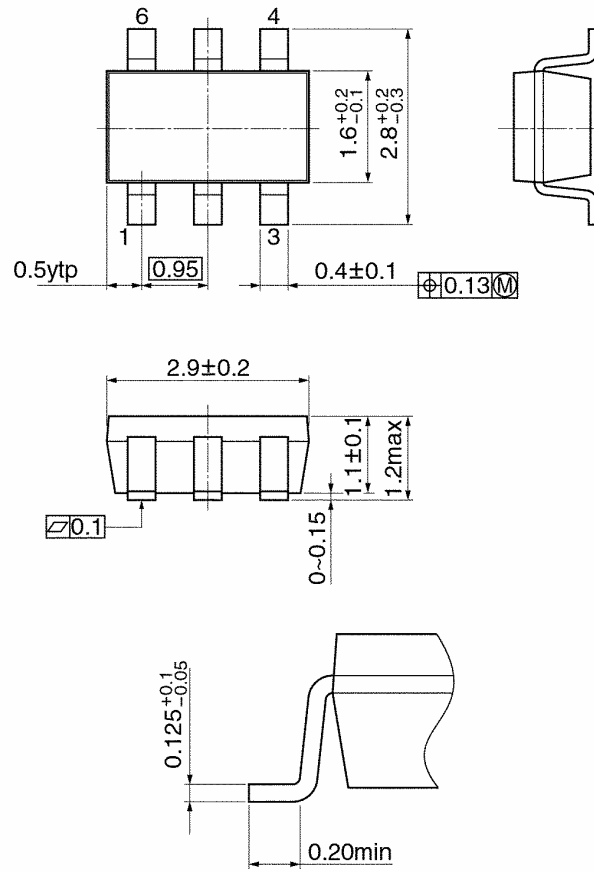

Weight: 0.016 g (typ.)

**RESTRICTIONS ON PRODUCT USE**

030619EBA

- The information contained herein is subject to change without notice.
- The information contained herein is presented only as a guide for the applications of our products. No responsibility is assumed by TOSHIBA for any infringements of patents or other rights of the third parties which may result from its use. No license is granted by implication or otherwise under any patent or patent rights of TOSHIBA or others.
- TOSHIBA is continually working to improve the quality and reliability of its products. Nevertheless, semiconductor devices in general can malfunction or fail due to their inherent electrical sensitivity and vulnerability to physical stress. It is the responsibility of the buyer, when utilizing TOSHIBA products, to comply with the standards of safety in making a safe design for the entire system, and to avoid situations in which a malfunction or failure of such TOSHIBA products could cause loss of human life, bodily injury or damage to property.  
In developing your designs, please ensure that TOSHIBA products are used within specified operating ranges as set forth in the most recent TOSHIBA products specifications. Also, please keep in mind the precautions and conditions set forth in the "Handling Guide for Semiconductor Devices," or "TOSHIBA Semiconductor Reliability Handbook" etc..
- The TOSHIBA products listed in this document are intended for usage in general electronics applications (computer, personal equipment, office equipment, measuring equipment, industrial robotics, domestic appliances, etc.). These TOSHIBA products are neither intended nor warranted for usage in equipment that requires extraordinarily high quality and/or reliability or a malfunction or failure of which may cause loss of human life or bodily injury ("Unintended Usage"). Unintended Usage include atomic energy control instruments, airplane or spaceship instruments, transportation instruments, traffic signal instruments, combustion control instruments, medical instruments, all types of safety devices, etc.. Unintended Usage of TOSHIBA products listed in this document shall be made at the customer's own risk.
- The products described in this document are subject to the foreign exchange and foreign trade laws.
- TOSHIBA products should not be embedded to the downstream products which are prohibited to be produced and sold, under any law and regulations.