

May 1990

## BiMOS Precision Operational Amplifiers

### Features:

- Low  $V_{IO}$ : 200  $\mu\text{V}$  max. (CA3493A)  
500  $\mu\text{V}$  max. (CA3493A)
- Low  $\Delta V_{IO}/\Delta T$ : 3  $\mu\text{V}/^\circ\text{C}$  max. (CA3493A)  
5  $\mu\text{V}/^\circ\text{C}$  max. (CA3493)
- Low  $I_{IO}$  and  $I_I$
- Low  $\Delta I_{IO}/\Delta T$ : 150  $\text{pA}/^\circ\text{C}$  max. (CA3493)
- Low  $\Delta I_I/\Delta T$ : 3.7  $\text{nA}/^\circ\text{C}$  max. (CA3493)

### Applications:

- Thermocouple preamplifiers
- Strain-gauge bridge amplifiers
- Summing amplifiers
- Differential amplifiers
- Bilateral current sources
- Log amplifiers
- Differential voltmeters
- Precision voltage references
- Active filters
- Buffers
- Integrators
- Sample-and-hold circuits
- Low frequency filters

The CA3493A and CA3493 are ultra-stable, precision instrumentation, operational amplifiers that employ both PMOS and bipolar transistors on a single monolithic chip. The CA3493A and CA3493 amplifiers are internally phase compensated and provide a gain-bandwidth product of 1.2 MHz. They are pin compatible with the industrial types such as 725, 108A, OP-7, LM11 and LM714 where positive nulling is employed.

Because of their low offset voltage and low offset voltage-versus-temperature coefficient the CA3493A and CA3493 amplifiers have a wider range of applications than most op amps and are particularly well suited for use as thermocouple amplifiers, high gain filters, buffer, strain gauge bridge amplifiers and precision voltage references.

The op amps are functionally identical. The CA3493 and CA3493A operate from supply voltage of  $\pm 3.5\text{ V}$  to  $\pm 18\text{ V}$  and have operating temperature ranges of  $0^\circ\text{C}$  to  $+70^\circ\text{C}$  and  $-25^\circ\text{C}$  to  $+85^\circ\text{C}$ , respectively.

These types are supplied in standard 8-lead TO-5-style (T suffix), 8-lead dual-in-line formed lead TO-5-style (DIL-CAN S suffix) and 8-lead dual-in-line plastic (Mini-DIP E suffix) packages.

### Circuit Description

The block diagram of the CA3493 amplifier, Fig. 2, shows the voltage gain and supply current for each of its four amplifier stages. Simplified and complete schematic diagrams of the CA3493 amplifier are shown in Figs. 3 and 4, respectively.

# CA3493A, CA3493

## Absolute-Maximum Ratings, Absolute-Maximum Values at $T_A = 25^\circ\text{C}$

	CA3493A	CA3493
DC Supply Voltage	$\pm 18$	$\pm 18$ V
Differential-Mode Input Voltage	$\pm 5$	$\pm 5$ V
Common-Mode DC Input Voltage	$(V^+ - 4), V^-$	$(V^+ - 4), V^-$ V
Input Terminal Current	1	1 mA

### Device Dissipation

Without Heat Sink		
Up to $55^\circ\text{C}$	630	630 mW
Above $55^\circ\text{C}$	Derate Linearly 6.67	mW/ $^\circ\text{C}$
Temperature Range	$-25$ to $85$	$0$ to $70^\circ\text{C}$
Output Short-Circuit Duration*	Indefinite	Indefinite
Lead Temperature (During Soldering) at distance of $1/16$ in. $\pm$ $1/32$ in. ( $1.59 \pm 0.79$ mm) from case for 10 seconds max.	$\pm 265$	$\pm 265^\circ\text{C}$

\*Short circuit may be applied to ground or to either supply.

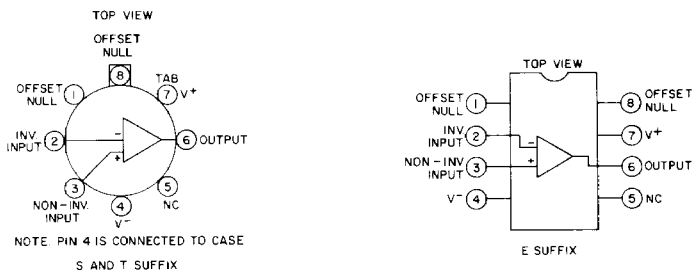

Fig. 1 - Functional diagram of CA3493A and CA3493.

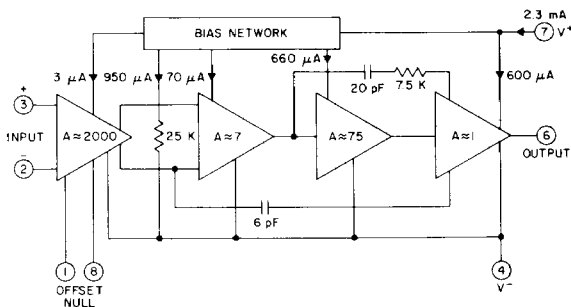

Fig. 2 - Block diagram of CA3493A and CA3493.

### Circuit Description (cont'd)

A quad of physically cross-connected n-p-n transistors comprise the input-stage differential pair (Q1,Q2 in Figs. 3 and 4); this arrangement contributes to the low input offset-voltage characteristics of the amplifier. The ultra-high gain provided in the first stage ensures that subsequent stages cannot significantly influence the

overall offset-voltage characteristics of the amplifier. High load impedances for the input-stage differential pair (Q1,Q2) are provided by the cascode-connected p-n-p transistors Q3,Q5 and Q4,Q6, thereby contributing to the high gain developed in the stage.

The second stage of the amplifier consists of a differential amplifier employing PMOS/FETs (Q7,Q8 in Figs. 3 and 4) with

3  
OPERATIONAL  
AMPLIFIERS

CA3493A, CA3493

ELECTRICAL CHARACTERISTICS at  $T_A = 25^\circ\text{C}$ ,  $V^+ = 15\text{ V}$  and  $V^- = 15\text{ V}$  unless otherwise specified.

CHARACTERISTIC	LIMITS						UNITS
	CA3493A			CA3493			
	Min.	Typ.	Max.	Min.	Typ.	Max.	
Input Offset Voltage, $ V_{IO} $	—	140	200	—	300	500	$\mu\text{V}$
$V_{IO}$ @ Max.Temp.	—	—	380	—	—	725	$\mu\text{V}$
Input Offset Voltage Temp. Coefficient, $\Delta V_{IO}/\Delta T$ (Over specified temperature range for each device)	—	1	3	—	1	5	$\mu\text{V}/^\circ\text{C}$
Input Offset Current, $I_{IO}$	—	3	5	—	5	10	nA
$ I_{IO} $ @ Max.Temp.	—	—	11	—	—	17	nA
Input Offset Current Temp. Coefficient, $\Delta I_{IO}/\Delta T$ (Over specified temperature range for each device)	—	0.03	0.10	—	0.04	0.15	nA/ $^\circ\text{C}$
Input Bias Current, $I_B$	—	10	20	—	20	40	nA
$ I_B $ @ Max.Temp.	—	—	83	—	—	207	nA
Input Bias Current Temp. Coefficient, $\Delta I_B/\Delta T$	—	0.10	1.18	—	0.15	3.70	nA/ $^\circ\text{C}$
Input Noise Voltage, $e_n$ p-p (0.1 to 10 Hz)	—	0.36	—	—	0.36	—	$\mu\text{V p-p}$
Input Noise Voltage Density, $e_n$ $f_o = 10\text{ Hz}$	—	25	—	—	25	—	$\frac{\text{nV}}{\sqrt{\text{Hz}}}$
$f_o = 100\text{ Hz}$	—	25	—	—	25	—	
$f_o = 1000\text{ Hz}$	—	24	—	—	24	—	
$f_o = 10\text{ kHz}$	—	24	—	—	24	—	
$f_o = 100\text{ kHz}$	—	22	—	—	22	—	
Input Noise Current, $i_n$ p-p (0.1 to 10 Hz)	—	12	20	—	12	20	pA p-p
Input Noise Current Density, $i_n$ $f_o = 10\text{ Hz}$	—	0.83	—	—	0.83	—	$\frac{\text{pA}}{\sqrt{\text{Hz}}}$
$f_o = 100\text{ Hz}$	—	0.80	—	—	0.80	—	
$f_o = 1000\text{ Hz}$	—	0.75	—	—	0.75	—	
$f_o = 10\text{ kHz}$	—	0.72	—	—	0.72	—	
$f_o = 100\text{ kHz}$	—	0.60	—	—	0.60	—	

CA3493A, CA3493

ELECTRICAL CHARACTERISTICS at  $T_A = 25^\circ\text{C}$ ,  $V^+ = 15\text{ V}$  and  $V^- = -15\text{ V}$  (Cont'd)  
 unless otherwise specified.

CHARACTERISTIC	LIMITS						UNITS
	CA3493A			CA3493			
	Min.	Typ.	Max.	Min.	Typ.	Max.	
Common-Mode Input Voltage Range, $V_{ICR}$	-12	-13.5 to 11.5	10	-12	-13.5 to 11.5	10	V
Common-Mode Rejection Ratio, $(V_{CM} = V_{ICR})$	110	115	—	100	110	—	dB
		1.78	3.16		3.16	10	$\mu\text{V/V}$
Power Supply Rejection Ratio, PSRR, $\Delta V_{IO}/\Delta V \pm$	100	130	—	100	130	—	dB
		0.316	10		0.316	10	$\mu\text{V/V}$
Maximum Output Voltage Swing ( $R_L \geq 2\text{ K}\Omega$ )	$\pm 13.0$	$\pm 13.5$	—	$\pm 13.0$	$\pm 13.5$	—	V
Large-Signal Voltage Gain ( $V_O = \pm 10$ ) $R_L \geq 1\text{ K}\Omega$ $R_L \geq 2\text{ K}\Omega$ $R_L \geq 10\text{ K}\Omega$	—	—	—	—	—	—	dB
	110	115	—	100	110	—	
	—	125	—	—	115	—	
	—	—	—	—	—	—	
Short-Circuit Output Current to the Opposite Rail, $I_{OM}^+$ , $I_{OM}^-$	-25	$\pm 7$	25	-25	$\pm 7$	25	mA
Slew Rate, SR ( $R_L \geq 2\text{ K}\Omega$ ; Unity Gain Voltage Follower)	—	0.25	—	—	0.25	—	$\text{V}/\mu\text{s}$
Gain-Bandwidth Product, $f_t$ $A_{OL} = 0\text{ dB}$ $R_L = 2\text{ k}\Omega$ $C_L = 100\text{ pF}$ $V_{IN} = 20$ $f = 1\text{ kHz}$	—	1.20	—	—	1.20	—	MHz
Small-Signal Transient Response, $t_r$ $(V_{IN} = 20\text{ mV p-p}, f = 1\text{ kHz})$	—	0.29	—	—	0.29	—	$\mu\text{s}$
Supply Current, $R_L = \infty$ $V^+ = 15$ , $V^- = -15$	—	2.3	3.5	—	2.3	3.5	mA
Temperature Range	-25	—	85	0	—	70	$^\circ\text{C}$

3  
OPERATIONAL AMPLIFIERS

# CA3493A, CA3493

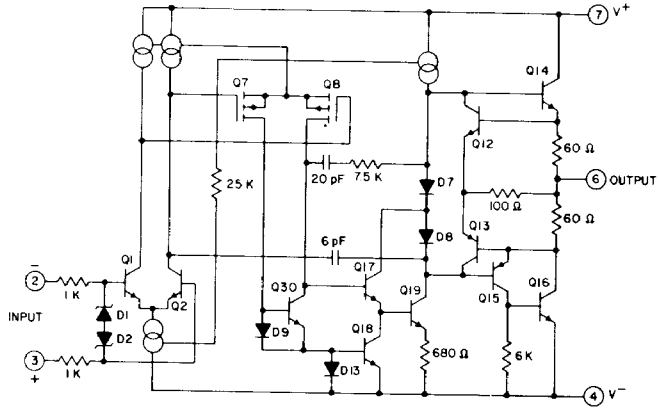

Fig. 3 - CA3493 simplified schematic diagram.

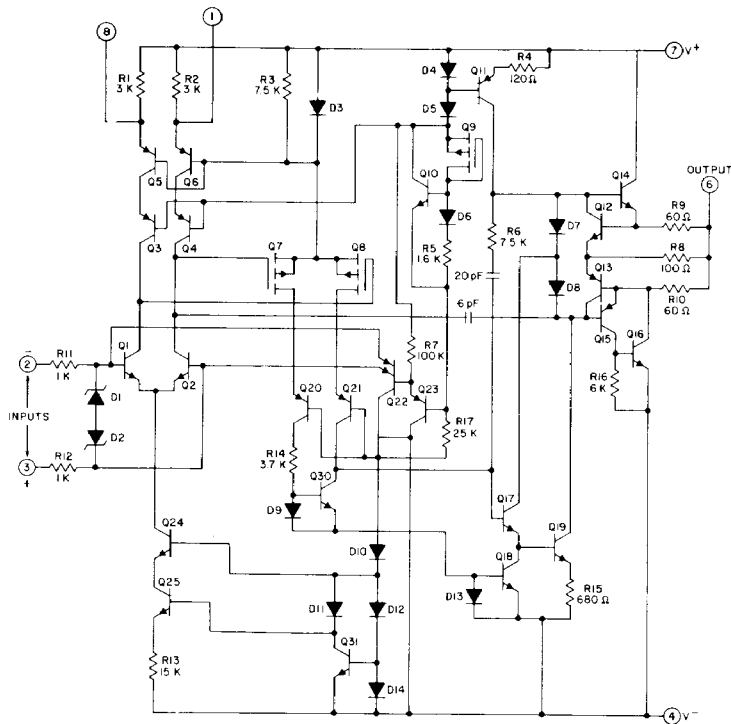

Fig. 4 - Schematic diagram of CA3493A and CA3493.

**Circuit Description (cont'd)**

appropriate drain loading. Since Q7 and Q8 are MOS/FETs, their loading on the first stage is quite low, thereby making an additional contribution to the high gain developed in the first stage. The second stage is also configured to convert its differential signal to a single-ended output signal by means of current mirror D9,Q30 (Figs. 3 and 4) to drive subsequent gain stage.

The third stage of the amplifier consists of Darlington-connected n-p-n transistors (Q17,Q19 in Figs. 3 and 4), driving the quasi-complementary Class AB output stage (Q14 and Q15,Q16 in Figs. 3 and 4). Output-stage short-circuit protection is activated by voltage drops developed

across the 60-ohm resistors adjacent to the output terminal (R9 and R10, Fig. 4). When the voltage drop developed across either of these resistors reaches a potential equal to  $1 V_{be}$ , the respective protective transistor (Q12 or Q13) is activated and shunts the base drive from the bases of the output stage transistors (Q14 and Q15,Q16).

Internal frequency compensation for the CA3493 amplifier is provided by two internal networks, a 6-pF capacitor connected between the input-stage transistor collectors and the node between the third and output stages and a second network, consisting of a 20-pF capacitor in series with a 7.5-K $\Omega$  resistor connected between the input and output nodes of the third stage.

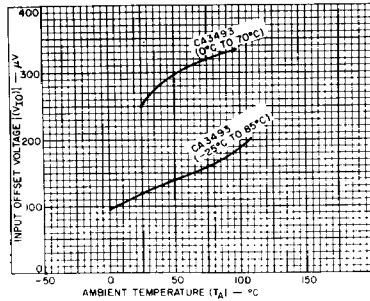

Fig. 5 - Typical input offset-voltage temperature characteristic for CA3493A and CA3493.

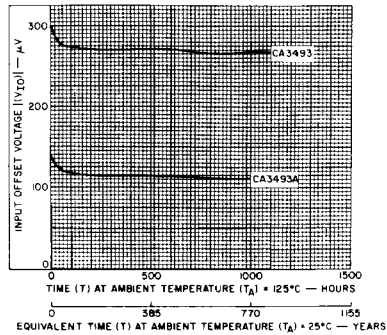

Fig. 6 - Input offset voltage vs. time.

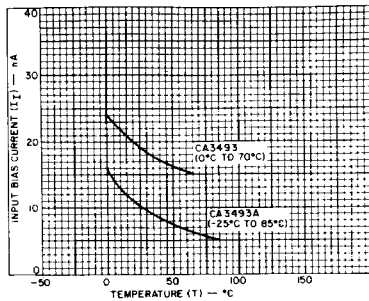

Fig. 7 - Typical input bias current vs. temperature

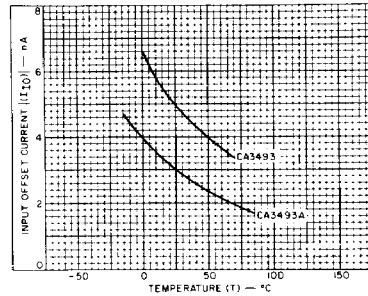

Fig. 8 - Typical input offset current vs. temperature.

# CA3493A, CA3493

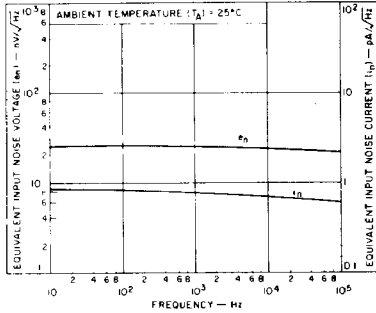

Fig. 9 — Input noise voltage and current density vs. frequency.

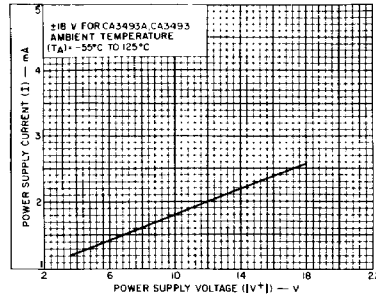

Fig. 10 — Power supply voltage ( $V^+$ ,  $V^-$ ) vs. supply current.

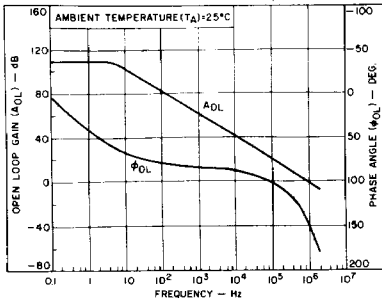

Fig. 11 — Open-loop gain and phase-shift response for CA3493.

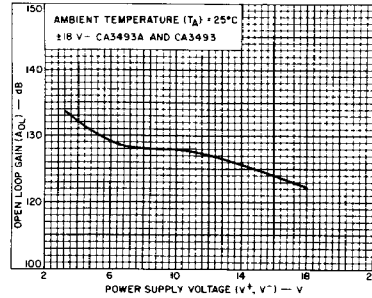

Fig. 12 — Open-loop gain vs. power-supply voltage.

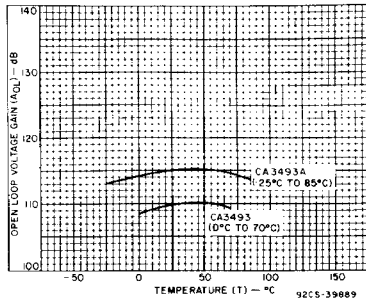

Fig. 13 — Open-loop gain vs. temperature for CA3493A and CA3493.

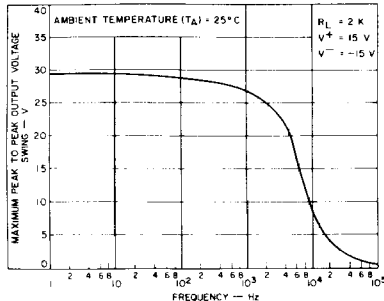

Fig. 14 — Maximum undistorted output voltage vs. frequency.

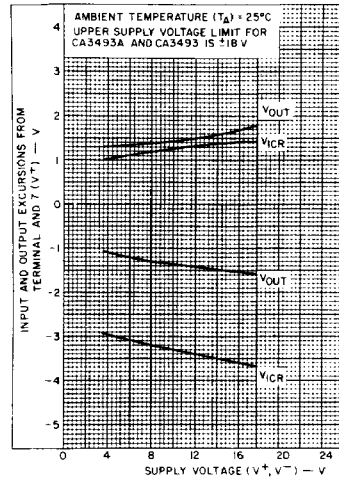
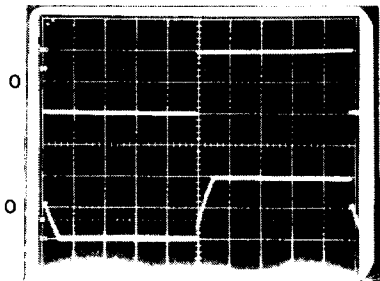
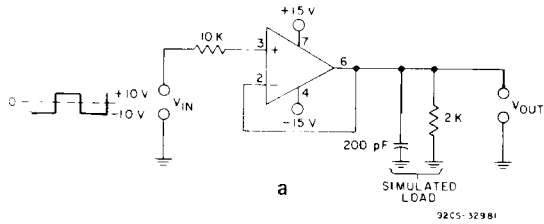

Fig. 15 — Output-voltage-swing capability and common-mode input-voltage vs. supply voltage.





CA3493A, CA3493



TOP TRACE : INPUT VOLTAGE  
 BOTTOM TRACE : OUTPUT VOLTAGE

VERT:  $\frac{10V}{DIV}$        $V^+ = 15V$   
 $V^- = 15V$   
 HOR:  $\frac{1ms}{DIV}$        $R_L = 2K$

Fig. 18 - Voltage follower (a) test circuit  
 (b) response to 20-V p-p, 1-kHz square-wave input.

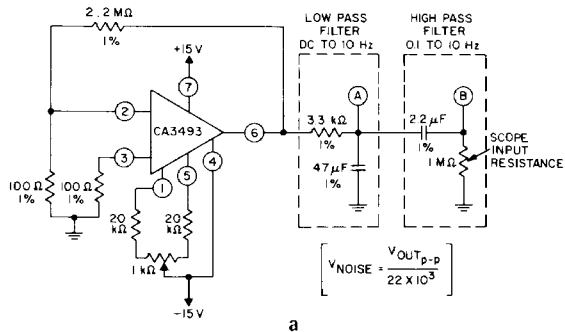

$$V_{NOISE} = \frac{V_{OUT-p-p}}{22 \times 10^3}$$

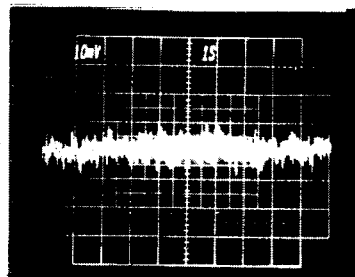
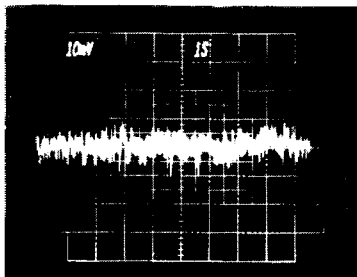
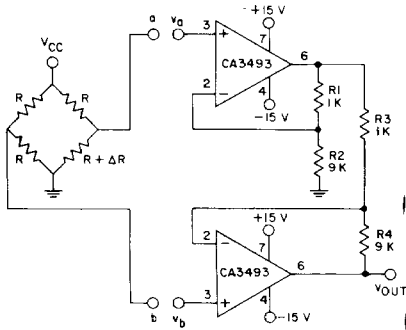

Fig. 19 - Low frequency noise (a) test circuit—0.1 to 10 Hz (b) output A waveform—0 to 10 Hz noise (c) output B waveform—0 to 10 Hz noise.

Application Circuits



$$V_{OUT} = -v_a \left( \frac{R_2}{R_1} + 1 \right) \frac{R_4}{R_3} + v_b \left( \frac{R_4}{R_3} + 1 \right)$$

FOR IDEAL RESISTORS WITH  $\frac{R_1}{R_2} = \frac{R_3}{R_4}$

$$V_{OUT} = v_b - v_a \left( \frac{R_4}{R_3} + 1 \right)$$

$$A = \frac{V_{OUT}}{v_b - v_a} = \left( \frac{R_4}{R_3} + 1 \right)$$

FOR VALUES ABOVE  $V_{OUT} = (v_b - v_a) (10)$

Fig. 20 - Typical two-op amp bridge-type differential amplifier.

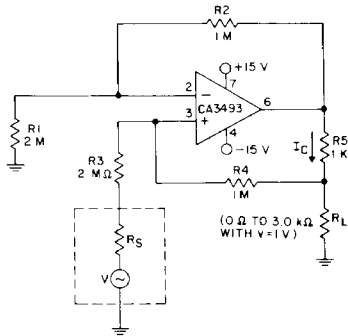

ALL RESISTORS ARE 1%

IF  $R_1 = R_3$  AND  $R_2 \approx R_4 + R_5$  THEN

$I_L$  IS INDEPENDENT OF VARIATIONS IN  $R_L$   
FOR  $R_L$  VALUES OF  $0 \Omega$  TO  $3.0 \text{ k}\Omega$  WITH  $v = 1 \text{ V}$

$$I_L = \frac{v}{R_3 R_5} = \frac{v}{(2 \text{ M})(1 \text{ K})} = \frac{v}{2 \text{ K}} = 500 \mu\text{A}$$

Fig. 22 - Using CA3493 as a bilateral current source.

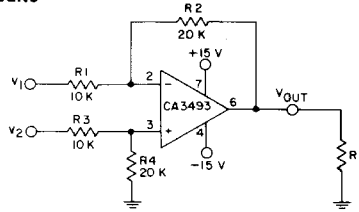

ALL RESISTANCE VALUES ARE IN OHMS

$$V_{OUT} = v_2 \left( \frac{R_4}{R_3 + R_4} \right) \left( \frac{R_1 + R_2}{R_1} \right) - v_1 \left( \frac{R_2}{R_1} \right)$$

IF  $R_4 = R_2, R_3 = R_1$  AND  $\frac{R_2}{R_1} = \frac{R_4}{R_3}$

THEN  $V_{OUT} = (v_2 - v_1) \left( \frac{R_2}{R_1} \right)$

FOR VALUES ABOVE  $V_{OUT} = 2(v_2 - v_1)$

IF  $A_V$  IS TO BE MADE 1 AND IF  $R_1 = R_3 = R_4 = R$   
WITH  $R_2 = 0.999 R$  (0.1% MISMATCH IN  $R_2$ )

THEN  $V_{OCM} = 0.0005 V_{IN}$  OR  $CMRR = 66 \text{ dB}$   
THUS, THE  $CMRR$  OF THIS CIRCUIT IS LIMITED BY  
THE MATCHING OR MISMATCHING OF THIS NETWORK  
RATHER THAN THE AMPLIFIER.

Fig. 21 - Differential amplifier (simple subtractor) using CA3493.

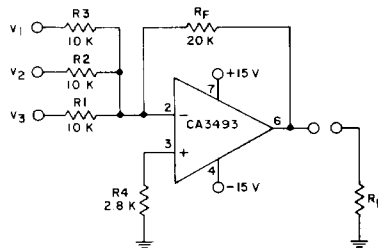

$$V_{OUT} = - \left( \frac{R_F}{R_1} v_1 + \frac{R_F}{R_2} v_2 + \frac{R_F}{R_3} v_3 \right)$$

$$V_{OUT} = - (2 v_1 + 2 v_2 + 2 v_3)$$

ALL RESISTANCE VALUES ARE IN OHMS

Fig. 23 - Typical summing amplifier application.

## CA3493A, CA3493

The CA3493 is an excellent choice for use with thermocouples. In Fig. 24, the CA3493 amplifies the signal generated 500 times.

The three 22-megohm resistors will provide full-scale output if the thermocouple opens.

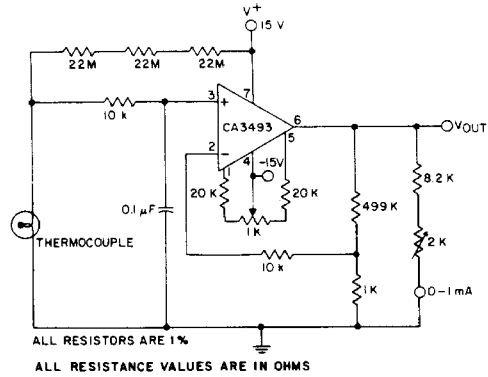

Fig. 24 - The CA3493 used in a thermocouple circuit.