

<Summary>

BIC221C is a high efficiency POWER-IC of MCM (multi chip module) with synchronous rectification system chopper control part, N channel MOSFET of main switch and low side MOSFET for synchronous rectification. Maximum output is 3A, and for the input voltage range it corresponds to 4.5V-20V which covers 5V system low input voltage. The functions such as over-current protection, over-heat protection and ON/OFF control etc. are all put in the surface mount one-package IC, which makes it possible to achieve a small size and light DC-DC converter with very few external components.

<Features>

- Input voltage range of 4.5V to 20V.
- Adjustable output voltage range of 0.8V to 14V.
- Internal power MOSFET
- Maximum output current 3A
- Built-in MOSFET for main switch and MOSFET for commutation
- Over-Current protection (external resistor not required)
- Heat protection
- Remote ON / OFF control
- Lead-free correspondence

<Applications>

- Information distribution equipment
- Office automation equipment
- Electronic measuring instruments
- Home appliances
- Telecommunications equipment
- Factory automation equipment (Process control)
- Audio-video devices

<Nomenclature>

Model name: BIC221C

For packaging, only tape and reel is available.

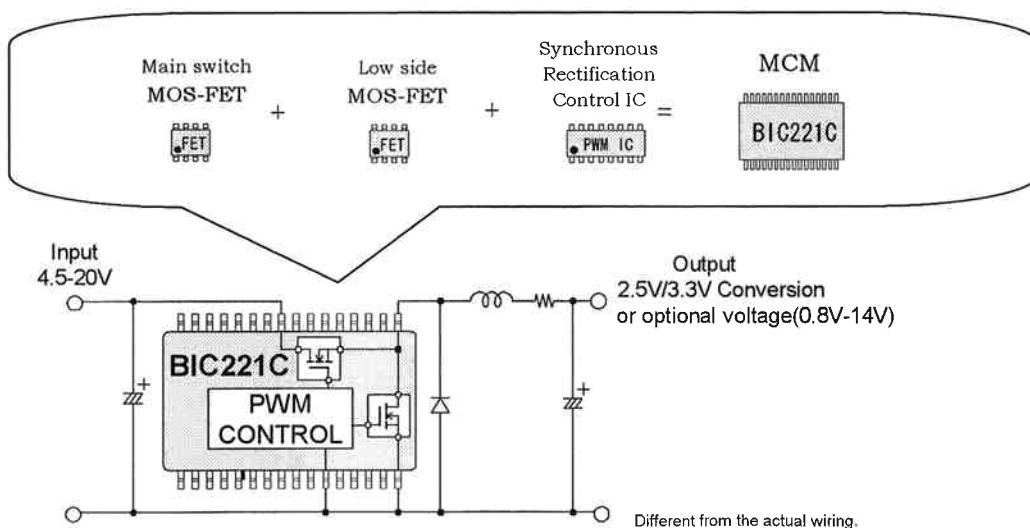

<Absolute Maximum Rating> (Ta=25°C)

Item	Symbol	Rating	Unit
Input voltage	Vcc	22	V
Main MOSFET input voltage	V _{BD}	22	V
Output current (ave)	I _{OUTave}	3	A
Output current (peak)	I _{OUTpeak}	4	A
Input voltage between V _B and V _{OUT}	V _B	5.5	V
Vboot sink current	I _{boot}	-30	mA
Remote control voltage	V _{RC}	Vcc	V
OSC input voltage	V _{OSC}	V _{ref}	V
LC input voltage	V _{LC}	V _{ref}	V
Amp- input voltage	V _{amp-}	V _{ref}	V
OCL-,OCL+ input voltage	V _{OCL}	a) Vcc-1.4 b) 14(Vcc>15.4V)	V
V _{ref} sink current	I _{ref}	-3	mA
Storage temperature	T _{stg}	-40 to 150	°C
Junction temperature	T _j	150	°C

<Recommended Operating Conditions> (Without otherwise specified Ta=25°C)

Item	Recommendation	Unit
Input voltage	4.5-20	V
Output voltage setting range	0.8-14	V
Operating temperature	-30 to 85	°C

<Electrical Characteristics>

Item	Condition	MIN	TYP	MAX	Unit
High side MOSFET					
Drain-source breakdown voltage	ID=1mA, VGS=0V	22	-	-	V
Zero gate voltage drain current	VDS=22V, VGS=0V	-	-	10	μA
Static drain-source on-state resistance	ID=1.2A VGS=4.5V	-	22	55	mΩ
Source-drain diode forward voltage	IS=1.2A, VGS=0V	-	-	1.5	V
Low side MOSFET					
Drain-source breakdown voltage	ID=1mA, VGS=0V	22	-	-	V
Zero gate voltage drain current	VDS=22V, VGS=0V	-	-	10	μA
Static drain-source on-state resistance	ID=1.2A VGS=4.5V	-	22	55	mΩ
Source-drain diode forward voltage	IS=1.2A, VGS=0V	-	-	1.5	V
Total device					
Supply current (f=100kHz)	Vcc=4.5~20V	-	3.3	3.9	mA
Supply current (f=300kHz)	Vcc=4.5~20V	-	5	5.9	mA
Supply current at remote OFF	Vcc=4.5~20V	-	25	50	μA
Undervoltage lockout section					
Undervoltage lockout threshold (start)	-	4.1	4.3	4.5	V
Undervoltage lockout hysteresis	-	0.4	0.5	0.6	V
Bootstrap section					
Bootstrap voltage	Vcc=5V	3.84	4	4.16	V
Line regulation	Vcc=4.5~20V	-	-	30	mV
Load regulation	Vcc=5V	-	-	30	mV
Reference section					
Reference voltage	Vcc=5V	3.84	4	4.16	V
Line regulation	Vcc=4.5~20V	-	-	30	mV
Load regulation	Vcc=5V	-	-	30	mV

Item	Condition	Min.	Typ.	Max.	Unit
Oscillator section					
Initial frequency1 accuracy (f=100kHz)	Vcc=5V	85	100	115	kHz
Initial frequency2 accuracy (f=300kHz)	Vcc=5V	255	300	345	kHz
Maximum duty cycle	Vcc=5V	85	90	95	%
Remote control section					
Remote control ON input voltage	Vcc=5V	-0.2	-	0.7	V
Remote control OFF input voltage	Vcc=5V	2	-	Vcc	V
Remote control source current	Vcc=5V	-	2	10	μA
Soft-start section					
Soft-start source current	Vcc=5V	-3	-2.5	-2	μA
Error amplifier section					
Error amplifier reference voltage	Vcc=5V	0.784	0.8	0.816	V
Over-current limit section					
Threshold of over-current limit at Ron detection	Vcc=5V	3	-	-	A
Threshold of over-current limit at external resistance detection	Vcc=5V	85	100	115	mV
Timer latch section					
Timer current	Vcc=5V	-40	-33	-26	μA
Soft-start input voltage before timer starting	Vcc=5V	2.75	2.9	3.05	V
Threshold of latch	Vcc=5V	3.3	3.45	3.6	V
Output section					
Output voltage accuracy (Vo=0.8V)	Vcc=4.5-20V	0.784	0.8	0.816	V
Output voltage accuracy (Vo=2.5V)	Vcc=4.5-20V	2.425	2.5	2.575	V
Output voltage accuracy (Vo=3.3V)	Vcc=4.5-20V	3.2	3.3	3.4	V
Thermal shutdown section					
Thermal shutdown temperature	-	-	140	-	°C

< Block Diagram >

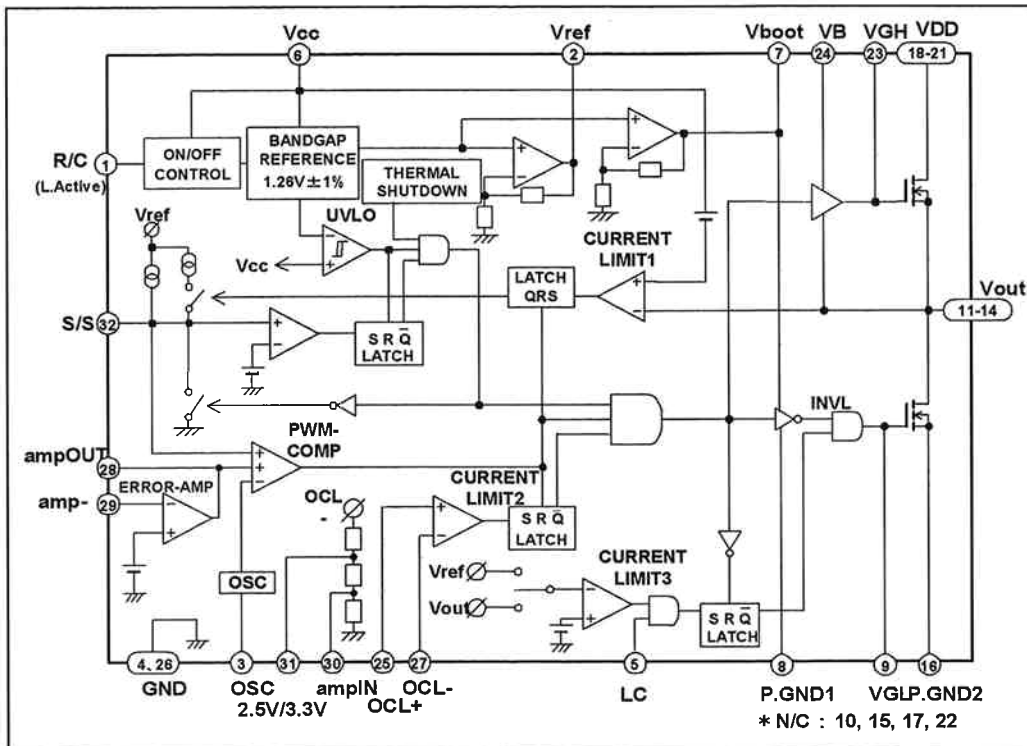

< External Dimensions >

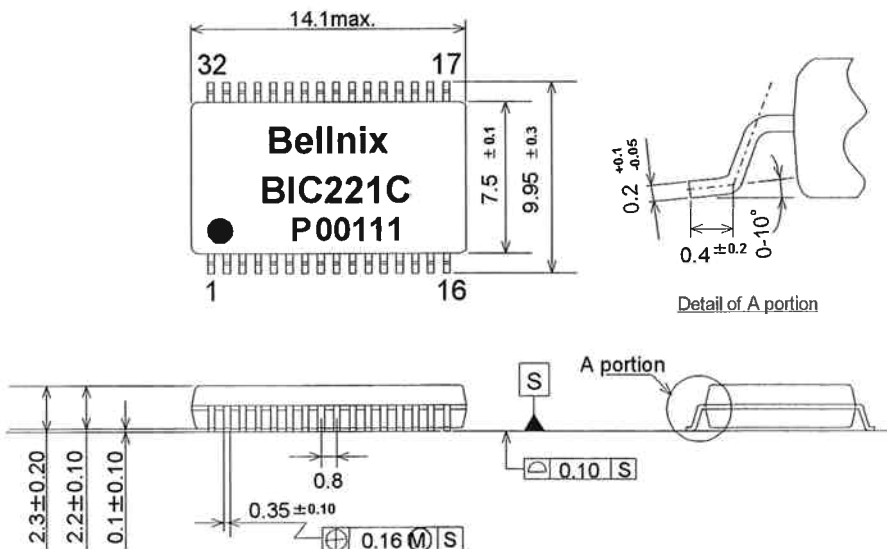

Terminal base: Cu
plating: Ni/ Pd/ Au

Case Epoxy resin (UL94 V-0)

Dimensions: mm

<Pin Functions>

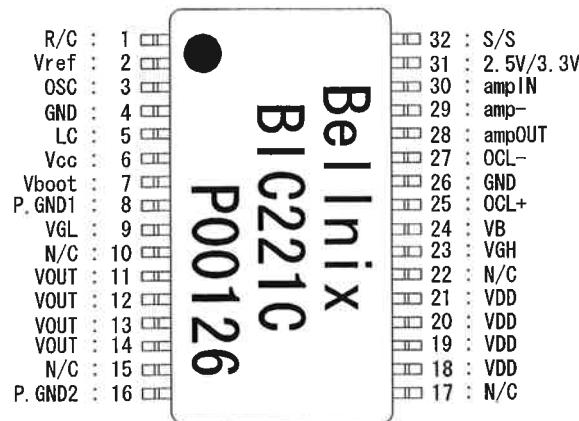

Pin number	Symbol	Function description
1	R/C	Terminal for remote control.
2	Vref	Terminal for internal reference voltage output.
3	OSC	Terminal for switching frequency select input. Connect to Vref at 300kHz select. Connect to GND at 100kHz select.
4,26	GND	Signal ground
5	LC	Terminal for cut-off detection function ON/OFF. Connect to Vref at ON. Connect to GND at OFF.
6	Vcc	Supply terminal for the control circuit.
7	Vboot	High side drive supply for high side MOSFET.
8	P.GND1	Power ground of low side driver.
9	VGL	Gate of low side MOSFET.
11-14	VOUT	Terminal for power stage output.
16	P.GND2	Source of low side MOSFET.
18-21	VDD	Drain of high side MOSFET.
23	VGH	Gate of high side MOSFET.
24	VB	Terminal for bootstrap. Bootstrap capacitor between VB and VOUT. Supply for high side circuit.
25	OCL+	Terminal for over current limit (+) at external resistance detection.
27	OCL-	Terminal for over current limit (-) at external resistance detection.
28	ampOUT	Terminal for error amplifier output.
29	amp-	Terminal for error amplifier (-) input. Connect to ampIN at 2.5V/3.3V output. Connect to point which divided by resistance for output voltage adjustable.
30	ampIN	Terminal for internal reference voltage detection output. Connect to amp (-) at internal reference detection select and 2.5V/3.3V output.
31	2.5V/3.3V	Terminal for 2.5V/ 3.3V output voltage select. At 2.5V output=OCL(-). At 3.3V output=open.
32	S/S	Terminal for soft-start. Connect capacitor to GND.
10,15,17,22	N/C	Non connection.

<Functions>

1. Setting the Output Voltage

BIC221C output voltage may be set between 0.8V and 14V. When set to 2.5V or 3.3V the internal dividing resistor is used and an external resistor is not required. Output voltage is set with a minimum accuracy of ±3%.

Three ways of setting the wiring for different output voltage.

1. For 2.5V output
2. For 3.3V output
3. For variable output 0.8V-14.0V or when adjusting the output

Wiring for 2.5V Output

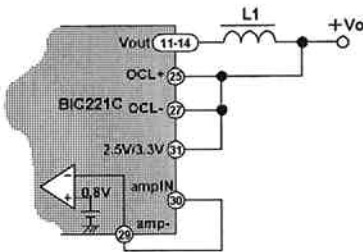

Wiring for 3.3V Output

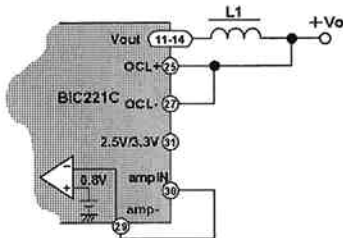

The internal dividing resistor is connected across the OCL and GND pins, with the dividing point connected to the ampIN pin. The ampIN pin should therefore be connected to the amp- pin externally.

Wiring for Variable Output

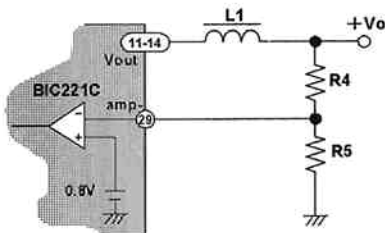

An external dividing resistor is required if output voltage is to be set to other than 2.5V or 3.3V. As the error amp reference voltage is 0.8V the value for the dividing resistor is determined with the equation below.

$$R5 = 1K [\Omega]$$

$$R4 = \frac{R5 \times (Vo - 0.8)}{0.8} [\Omega]$$

Vo : Output voltage [V]

As the reference voltage has a minimum accuracy of ±2%. The accuracy of the set output voltage is determined by the accuracy of the reference voltages and the accuracy of the resistor.

2. Selecting the Oscillation Frequency

The BIC221C incorporates an internal oscillator, and an external C.R is therefore not required. The oscillation frequency may be set to either 100kHz or 300kHz.

Switching losses in switching power supplies generally increase as the oscillation frequency increases, however the BIC221C is designed to provide sufficiently high efficiency at 300kHz.

Furthermore, the number of peripheral components (eg the inductor) is minimized, and thus a standard circuit using the 300kHz frequency provides benefits in terms of both cost and space. Use of the 100kHz frequency is effective in terms of reducing high frequency noise, and is more effective than the 300kHz frequency at low-load at which switching losses dominate.

The OSC pin is used in setting the oscillation frequency. The 300kHz frequency is selected by connecting the OSC pin to the Vref pin, and 100kHz by connecting it to the GND pin.

Frequency Switching

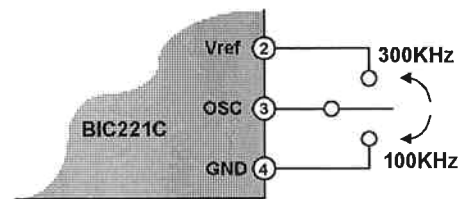

300KHz: Short between OSC pin and -Vref pin

100KHz: Short between OSC pin and -GND pin

3. The Soft Start Function

The BIC221C incorporates a soft start function to prevent overshoot at start-up and to reduce electrical stress on the device. As shown in the diagram below, the condenser (C2) is connected across the S/S and GND pins. As the duty ratio is limited by the voltage at the S/S pin, gradual charging of this condenser allows a fixed rate of increase in the output voltage.

Soft Start Circuit

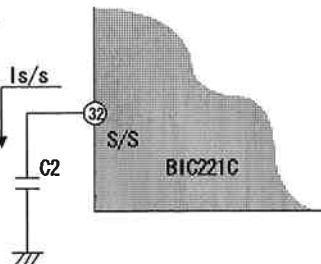

As shown in the diagram, the S/S pin is charged at a fixed current. When the voltage at this pin reaches 0.5V, main switch oscillation begins and output voltage increases. As the voltage at the S/S pin increases to a constant value of 2.9V the output voltage must reach the set voltage during that interval. If the capacitance of the output condenser is too high, the increase in the output voltage does not follow the increase at the S/S pin, thus preventing start-up in some cases.

Relationship Between Soft Start Voltage and Input/Output Voltage

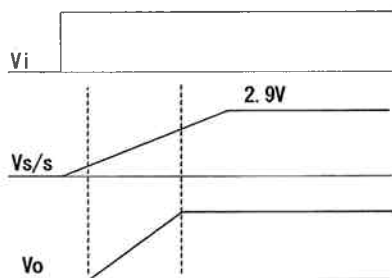

It is necessary to monitor output voltage V_o so that it is always started up in advance to the S/S terminal voltage. (Refer to the chart above) As shown in the graph below, the capacitance of the condenser connected to the S/S pin determines the start-up time.

Relationship Between S/S Condenser and Output Voltage Start-up Time

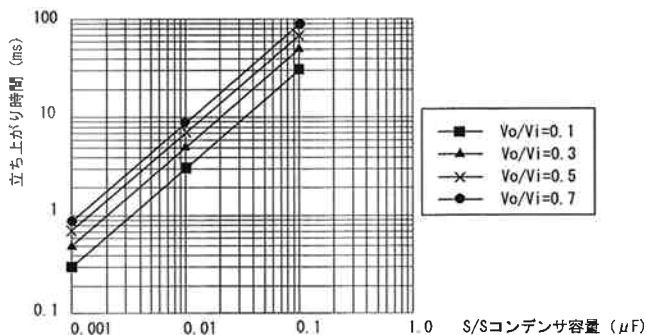

Select a high value for capacitance of the condenser connected to the S/S pin if latch is halted at start-up.

4. The Remote ON/ OFF Function (R/C)

An external signal may be used for ON/OFF control of the BIC221C. The BIC221C is switched ON when the R/C pin is set to L (0.7V or lower), and switched OFF when it is set to H (2V or higher), or is open. Current consumption at OFF is approximately 25μA.

As the R / C pin is pulled up internally it may be used as an open collector, thus eliminating the need for application of an external voltage. Any external voltage applied must be no higher than VCC.

When the remote ON / OFF function is used, a condenser is connected across the R/C and GND pins to prevent malfunctioning due to noise.

If the capacitance of this condenser is too high, the output voltage will be produced instantaneously when an input voltage is applied while the BIC221C is OFF. The capacitance of this condenser should be approximately 1/ 3 of that of the S / S condenser (C2) as obtained from the graph in 3. Soft Start Function.

Remote Control Circuit

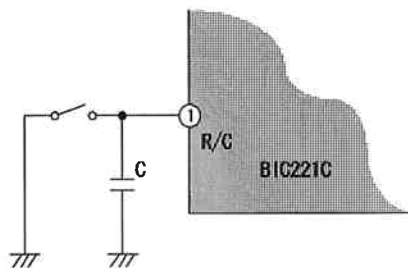

5. The Reference Voltage (Vref)

The BIC221C provides an internal temperature compensated reference voltage (4V) which may be used as a reference voltage up to 1mA for external circuits. A condenser (C8) of approximately 0.1μF is connected across the Vref and GND pins to prevent malfunctioning due to noise.

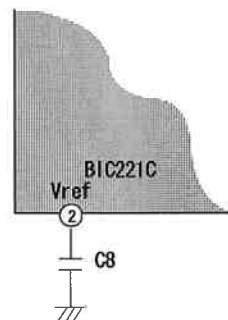

* Note that this voltage differs from the error amp reference voltage.

6. The Over-current Protection Function (timer latch)

The BIC221C incorporates an over-current protection function. As the over-current condition is detected with the use of the voltage drop resulting from the ON detection resistance is not required. When the over-current condition is detected the condenser (C2) connected to the S/S pin is charged again, and when level of 3.45V is reached the latch is halted.

To turn the timer latch off, use the R/C function to switch OFF the BIC221C, or switch OFF the power supply voltage.

This function also employs the S/S pin condenser as a timer. Determine the capacitance of this condenser in reference to the section on soft start.

Over-current Protection

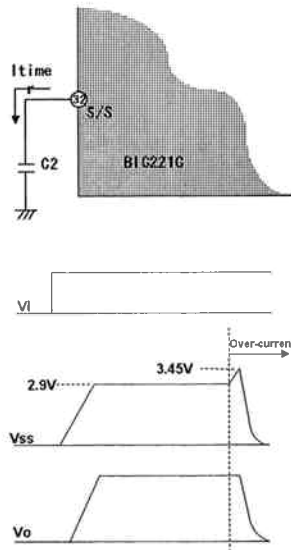

In the process of increasing the output voltage at startup, the converter generally charges the output condenser resulting in the over-current condition. When the over-current protection circuit operates the latch is halted and start-up becomes impossible. The BIC221C timer circuit is locked to prevent its operation until the voltage at the S/S pin reaches 2.9V, and when the S/S pin is fully charged the lock is cleared and the timer circuit is ready for operation. If, however, the output voltage does not rise by the time the S/S pin is charged to 2.9V, the over-current protection circuit operates and the latch is halted. The output voltage must therefore reach the set voltage before the voltage at the S/S pin reaches 2.9V.

7. The Current Limiting Function (external resistance detection)

In addition to over-current protection using the timer latch, the BIC221C incorporates a function to limit output current. Connection of an external resistor facilitates incorporation of droop characteristics for the output at any desired current value. Limiting the maximum output power simplifies start-up when the current supply capacity of the input power supply is low.

As shown in the diagram, the voltage drop across the inserted resistor (R2) is detected at 100mV.

The timer latch is disabled when droop characteristics are incorporated in the output using this function. When the impedance at the load side approaches zero, current increases and the timer latch operates to protect the circuit. The OCL+ and OCL- should be shorted if this function is not used.

Circuit for Current Limiting Function (external resistance detection)

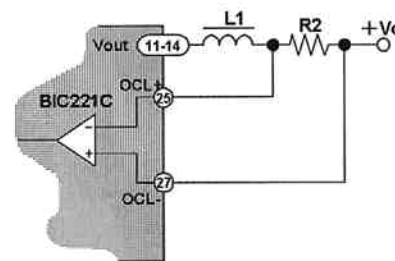

8. Short-circuit Protection

The short-circuit protection function described above operates when the output pin is completely short-circuited, or if power is switched on in the short-circuited condition, however as an extremely high current flows in the converter the latch circuit may not operate due to noise resulting from this short-circuit current. A protection circuit independent of the BIC221C should therefore be provided to accommodate such cases. (Refer to p. 16 External Protection Circuits.)

9. The Overheat Protection Function

The BIC221C incorporates an overheat protection function. The oscillator is halted when the junction temperature reaches 140°C due to operation under adverse conditions. The oscillator begins operation again when the temperature drops to 110°C. A reset signal is not required.

10. Error Amp Gain Adjustment

Error amp gain adjustment is effective in ensuring stable operation of the power supply circuit and good and good transient response. As the appropriate constant varies with the components used (eg output condenser), the BIC221C has an external error amp input/ output pin for adjustment following selection of the primary components.

Error Amp Gain Adjustment Circuit

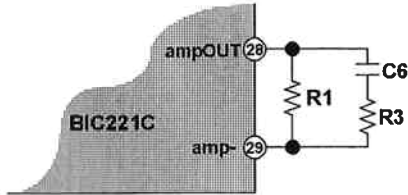

11. Bootstrap

The BIC221C employs an N-ch MOSFET in the high-side switch. The load supply circuit is bootstrapped to the gate of this MOSFET. A condenser (C3) is connected across the VB and VOUT pins as part of the power supply.

The capacitance of C3 must be sufficient in relation to the capacitance of the MOSFET gate. Use a ceramic condenser of approximately 0.1µF.

The load applied to C3 is supplemented from the Vboot pin via D1 with each pulse cycle. This is backed up by C4, while simultaneously stabilizing the voltage at the Vboot pin. The capacitance of C4 should therefore be equal to or greater than that of C3.

The voltage at the Vboot pin is controlled to 4V. As C3 is charged with a voltage which is less than this 4V by an amount equal to the VF of the diode D1 when the VF of this diode is high, the gate drive voltage drops and the previous performance is then not obtained. As the average current is in the order of a few mA, a small signal diode is sufficient, however it is important to avoid a diode with a high voltage resistance and high VF. (Refer to p. 14 Application Circuit Examples.)

Bootstrap Circuit

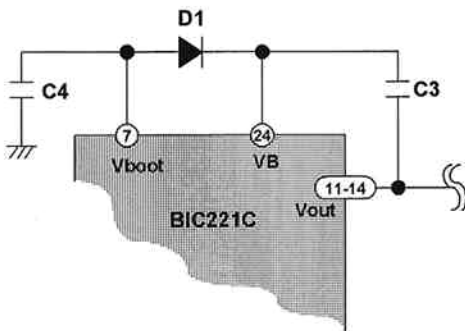

12. The L Cut (cut off detect) Function

As previously described, a continuous current normally flows in the choke coil. This current includes a ripple current determined by the inductance and input/ output voltage of the choke coil. As the average value is the output current, when the output current is less than $\Delta 1/2$ at low-load the current becomes discontinuous (cut-off).

The BIC221C allows selection of two operating modes in the cut-off region.

(1) Power Saving Mode (L cut ON)

This mode is ON when the LC and Vref pins are connected (H). When the choke coil current is cut-off the ON range is narrowed and the average current drops. As the current flowing in the MOSFET is reduced the losses at low-load are reduced, however variation in the ON range increases and transient response deteriorates in proportion. As power saving is beneficial at high input voltages, benefits at 5V are minimal and it is therefore recommended that (2) Current Regeneration Mode (L cut OFF) be used at low voltages.

L1 Current Waveform at Low-load

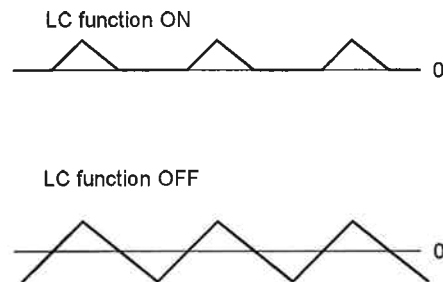

Input Current (Vi=20V) at Low-load

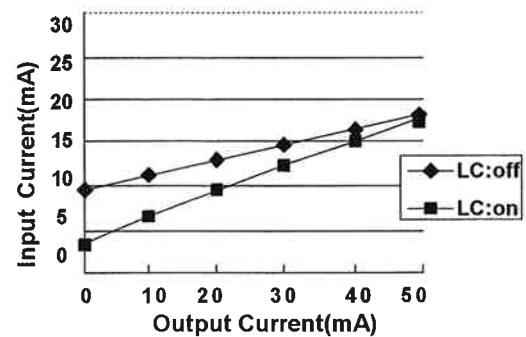

(2) Current Regeneration Mode (L cut OFF)

This mode is OFF when the LC and GND pins are connected (L). The current in the choke coil flows in the reverse direction, thus regenerating energy and resulting in a continuous current even at no-load.

As the ON range remains constant irrespective of the load applied, a stable response is obtained even under rapid changes in load from the no-load condition. On the other hand, as the actual current value increases, input current at low-load increases slightly in comparison with that at L cut ON.

Transient Response with LC ON/OFF

Conditions: $V_{in}=5V$
 $V_{out}=3.3V$

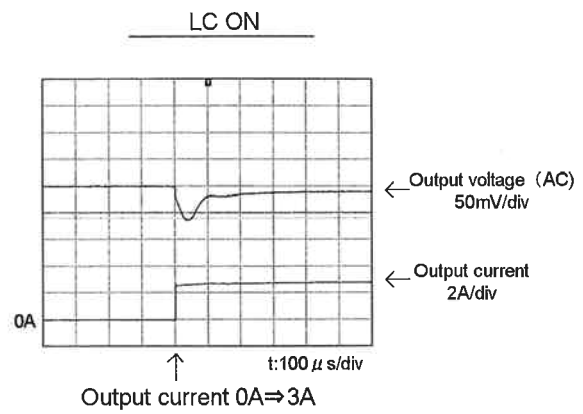
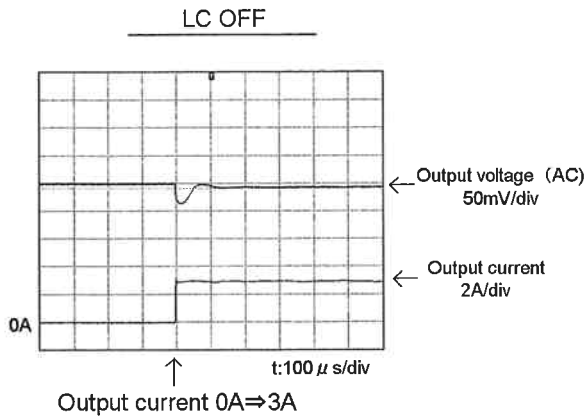

Transient response may be optimized with error amp gain adjustment (refer to p. 10 Error Amp Gain Adjustment for details).
 For the graph above, two 1200 μ F aluminum electrolytic condensers (C5) were used for the output condenser, a 100pF condenser for C6, and a 1M Ω resistor for R3.

Load current is extremely low, and the difference shown in the diagram is obtained at the transient response from the choke coil current cut-off region (up to approximately 15% of the maximum output current), however there is almost no difference in transient response due to LC ON/ OFF in the non-cut-off region.

<Selection of Primary Components and Pin Connections>

1. Standard Connection Diagram

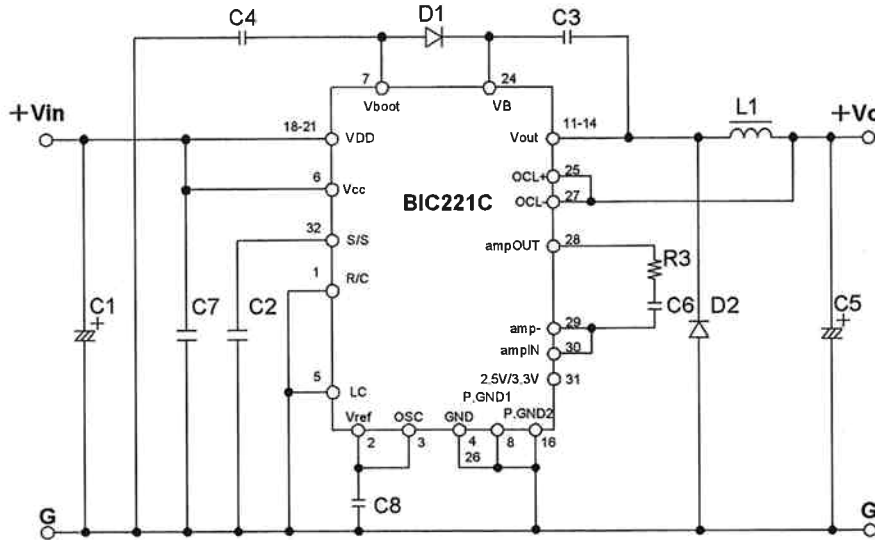

2. Selecting the Output Choke Coil (inductor) (L1)

The choke coil has an important effect on power supply performance. As a ripple current flows in the inductor as shown in the diagram below, the inductance should be selected to ensure that ΔI is approximately 30% of the maximum output current when the input voltage is at its maximum.

Current Waveform in Output Choke Coil (L1)

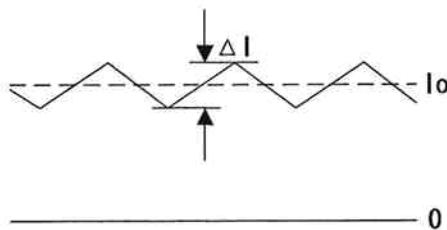

$$L = \frac{(V_{in(max)} - V_o) \times V_o}{\Delta I \times V_{in(max)} \times f} [H]$$

- $V_{in(max)}$: Maximum input voltage [V]
- V_o : Output voltage [V]
- ΔI : 30% of maximum output current [A]
- f : Oscillation frequency (100kHz or 300kHz) [Hz]
- I_o : Maximum output current [A]

The inductor is generally selected on the basis of the calculation, however in some cases the nature of the product may require an inductor which differs from the calculated value. An inductor in which ΔI is between 20% and 40% of the output current is recommended.

If a higher inductance value is selected the output ripple voltage is reduced, however as the current rating drops the size of the required inductor is increased. On the other hand, if a lower inductance value is selected the size of the required inductor is reduced while peak current is increased, thus slightly increasing the loss when a load is applied.

While the BIC221C incorporates an over-current protection function, the inductor selected must be such that magnetic saturation does not occur at the over-current detection point.

As a magnetic field is generated in the vicinity of the inductor, component layout and pattern design must be such as to ensure that they do not affect the control circuit. Toroidal or closed magnetic circuit pot type inductors are recommended for applications likely to be affected by magnetic field leakage and radiated noise.

3. Selecting the Output Condenser (C5)

An output condenser is required to reduce output ripple and thus obtain a stable DC voltage. The converter output ripple voltage is determined by ΔI and condenser impedance. The output condenser is selected in relation to the impedance. Select the output condenser based on the desired output ripple voltage using the following equation.

$$Z_c \leq \frac{V_{rip}}{\Delta I} [\Omega]$$

Z_c : Condenser impedance [Ω]

V_{rip} : Output ripple voltage [V]

ΔI : 30% of maximum output current [A]

The desired ripple voltage is obtained if a condenser with an impedance less than that calculated with the above equation is selected from the catalog.

In addition to a low impedance, the output condenser must also have a reasonable capacitance. Control will readily become unstable and amp gain adjustment will prove difficult if capacitance is low. Aluminum electrolytic condensers and functional high-polymer electrolytic condensers are of sufficiently high capacitance so that it need not be considered when selecting on the basis of the equation above. The use of such condensers, rather than ceramic or film condensers, is therefore recommended. On the other hand, concurrent use of ceramic or film condensers is effective in eliminating high frequency noise.

4-1. Selecting the Input Condenser (C1)

As a large ripple current flows in the input condenser it is necessary to consider the allowable value for ripple current. Select an input condenser with an allowable ripple current exceeding the value calculated in the equation below.

$$I_{rip} \geq \sqrt{D(1-D)} \times I_o [A]$$

$$D = \frac{V_o}{V_i}$$

I_{rip} : Allowable ripple current [A]

V_o : Output voltage [V]

V_i : Input voltage [V]

D : Duty ratio

I_o : Output current [A]

D is the ratio between the ON interval and the OFF interval, and I_{rip} is at a maximum when this value is 0.5. The capacitance of the input condenser need not be particularly high, however care is required if a ceramic or film condenser is used. As large ripple voltages are generated in the input condenser during charging and discharge, a particularly low input

voltage may result in operation becoming unstable. As this ripple voltage is returned to the input line other circuits powered from the same line may be affected. Interference may occur, particularly when using multiple DC-DC converters, and in such cases an inductor of a few μH is inserted in the stage before the input condenser to eliminate the problem.

4-2. Selecting the Input Condenser (C9)

The input condenser (C1) will consider the ripple allowable current and choose a low impedance product, however as the temperature falls, the impedance of this capacitor (C1) may rise.

Even at low-temperature, for stable operation of the converter, make sure to connect a multilayer ceramic condenser (C9: 10 μF or more) that has good temperature characteristics.

5. Selecting the Regenerative Diode (D2)

The BIC221C employs synchronous rectification using a regenerative MOSFET, and requires a diode to bypass the regenerative current during the dead-time interval. If this diode is not present regenerative current flows in the MOSFET body diode during the dead-time interval, resulting in increased losses and noise. A Schottky barrier diode with low VF is ideal for use in preventing current flowing in the body diode, however it is important that this diode has a low leakage current to prevent thermal runaway.

Recommended component :

D1FM3 (Shindengen)

30V, 3A VF =0.4V (max.) IR=0.1mA (max.)

M1FM3 (Shindengen)

30V, 2.1A VF =0.4V (max.) IR=0.05mA (max.)

<Application Circuit Examples>

1. Outline Specification

Input voltage : 12V

Output : 2.5V, 3A

Operating frequency : 300KHz

R/C, LC : OFF (Function is not used)

Over-current : Timer latch

2. Application Circuit Example

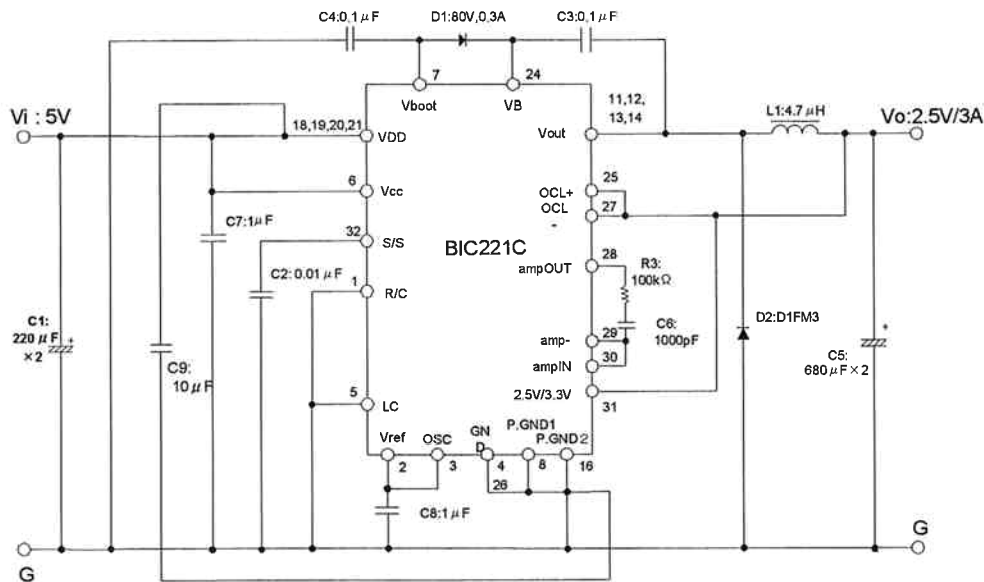

3. Component Examples

Component code	Type	Rating
C1	Electrolytic condenser	25V, 220μF×2pcs
C2	Ceramic condenser	25V, 0.01μF
C3	Ceramic condenser	25V, 0.1μF
C4	Ceramic condenser	25V, 0.1μF
C5	Electrolytic condenser	10V, 680μF×2pcs
C6	Ceramic condenser	25V, 1000pF
C7	Ceramic condenser	10V, 1μF
C8	Ceramic condenser	10V, 1μF
C9	Ceramic condenser	10V, 10μF
D1	Switching diode	80V, 300mA
D2	Schottky barrier diode	D1FM3 (30V, 3A)
L1	Inductor	4.7μH
R3	Resistor	100kΩ

<Mounting>

1. Substrate Mounting Example

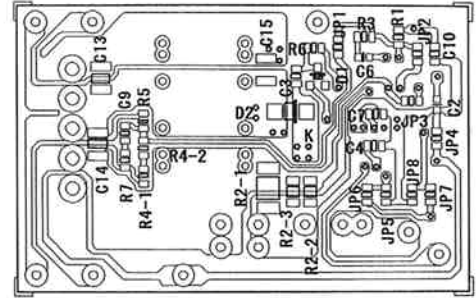
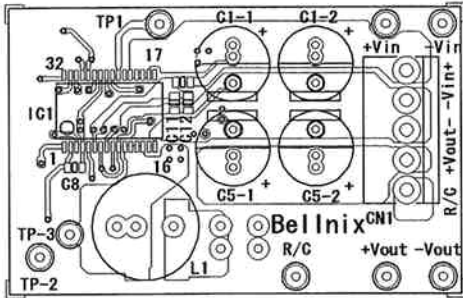

This is a substrate mounting example prepared for our evaluation board.

As this pattern does not incorporate an over-voltage protection circuit or input fuse (Refer to P. 16) they must be added separately if the circuit is to be used in practice.

2. Mounting cautions

Vibration and other mechanical disturbances can exert stress on the internal parts of the device. Carefully examine your equipment and place the device where vibration and other shock is minimal.

3. Soldering Conditions

The infrared reflow method is recommended. If the soldering time is too long or the soldering temperature is too high, it may damage the function of this IC, so be sure to use within the specified conditions.

1) Infrared reflow method

Temperature profile in the reflow method is as shown in the figure at the right.

2) Wave soldering conditions

- Pre-heating conditions

Center of the case temp.: 80-140°C

Pre-heating time: 30-60sec

- Heating conditions

Soldering temp.: 265±5°C

Heating time: 10±1sec

- Heating frequency: one time

- Notes

Solder bridge will be effected by the land, so give consideration when designing the printed board.

3) Storage conditions

After the dampproof package is opened, in an environment of temp. 30°C and relative temp. 70% or below: within 168Hrs.

4) Baking conditions

One time within 24Hrs. at 125°C

5) Soldering Iron

When using a soldering iron, execute under the following conditions.

- Soldering iron tip temp.: 380±10°C

- Heating time: 3±1sec

- Heating frequency: one time

Soldering Pad Reference Pattern

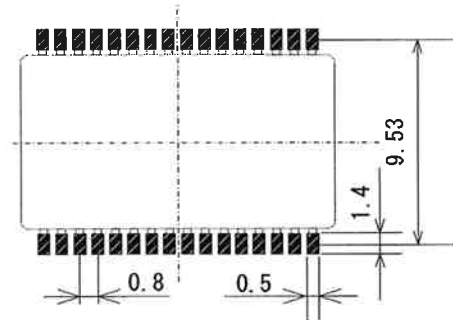

Infrared and air flow soldering conditions

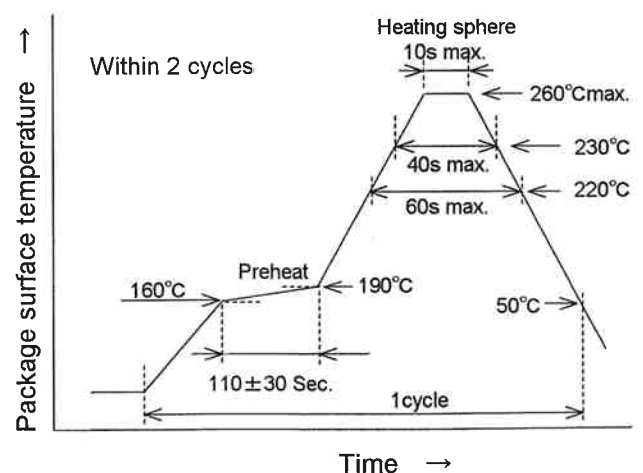

4. Cleaning cautions

Carefully remove all flux. Allow time for the soldered areas to completely dry before using the device.

5. Resinous Coating

When remolding after mounting the device to the board, if the curing stress of the resinous is strong, it may give stress to the component. So be careful of choosing the resinous and calcify time.

<External Protection Circuits>

1. Connection of Input Protection Devices

While the BIC221C incorporates both over-current protection and overheat protection functions, these protection circuits may not operate normally if a fault or a malfunction develops in the IC. A protective device (eg a fuse) should be inserted in the +ve input line to prevent overheating and consequent smoke or fire as a result of excess input current. Select the rated current of the fuse etc. in consideration of factors such as the DC-DC converter input current and current capacity of the input power supply.

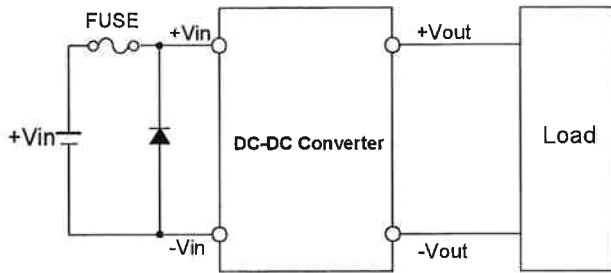

2. Connection of Over-voltage Protection Circuit

The BIC221C does not incorporate an over-voltage protection circuit. One of the modes supported is such that the input voltage will appear unchanged at the output despite operation being halted if the IC is damaged for any reason. Such damage to the load may result in smoke and fire, and an over-voltage protection circuit should therefore be added to prevent such problems.

A representative example of an over-voltage protection circuit is shown in the diagram below.

The over-voltage protection circuit is inserted on the load side of the output smoothing condenser.

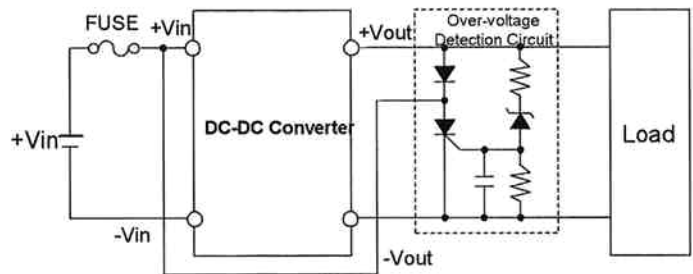

3. Reverse Bias Protection Between Output pin and GND pin

Due to the BIC221C control characteristic, at turn-off transient, a reverse current from the output capacitor will flow into the smooth coil and generate minus voltage at the output. To keep this minus voltage low, connect a schottky diode with a low Vf between the output pin and GND pin.

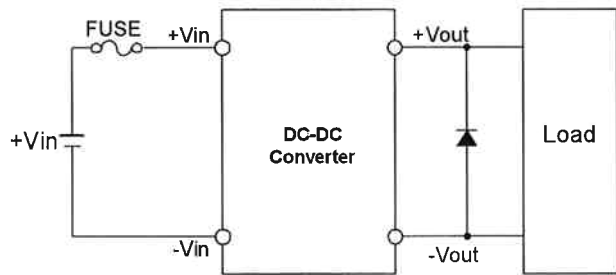

<Characteristics Ex. >

1) Efficiency and Loss - Output current characteristics

Conditions LC: OFF, f=300kHz, L=12μH
 Vout=3.3V

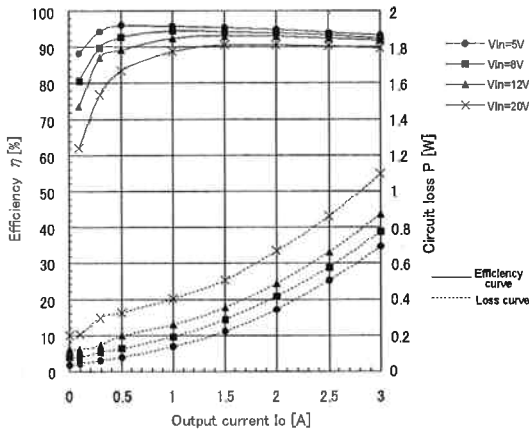

2) Line Regulation Data

Conditions LC: OFF, f=300kHz, L=12μH
 Vout=3.3V

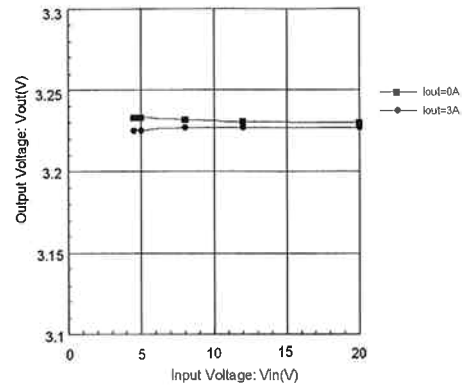

3) Load Regulation Data

Conditions LC: OFF, f=300kHz, L=12μH
 Vout=3.3V Vin=At 5V

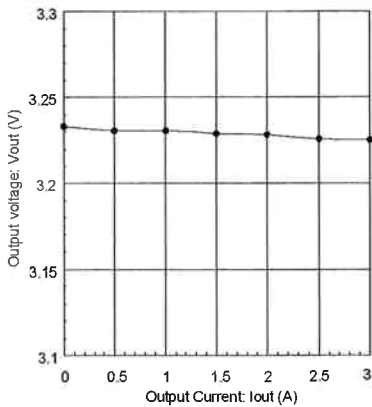

4) Output Voltage Efficiency Data

Conditions LC: OFF, f=300kHz, L=12μH
 Vin=5.0V Ta=25°C
 Output Voltage Vo=0.8V, 1.2V, 1.8V, 2.5V, 3.3V

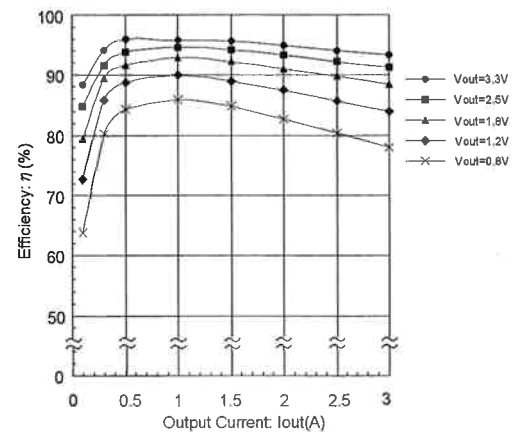

Power IC BIC221C

<Packaging>

1. Tape

Material: PVC+carbon

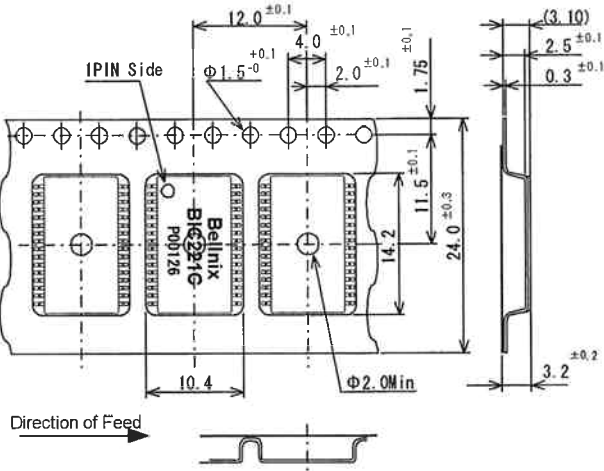

Dimensions: mm

2. Reel

Materials: Polystyrene+Carbon

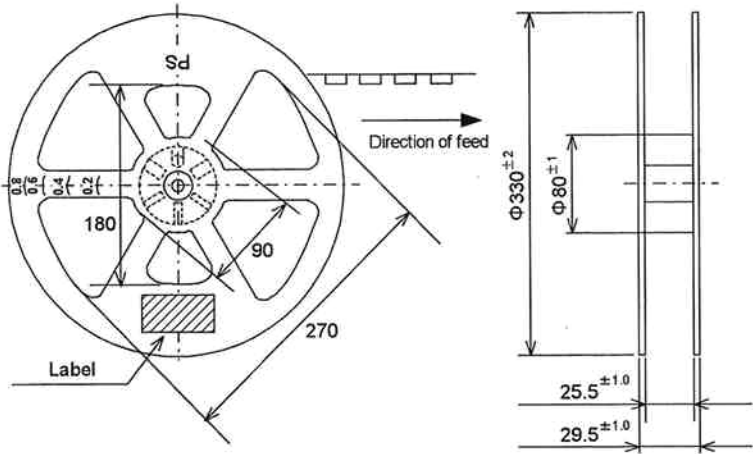

Dimensions: mm

3. Leader and Trailer

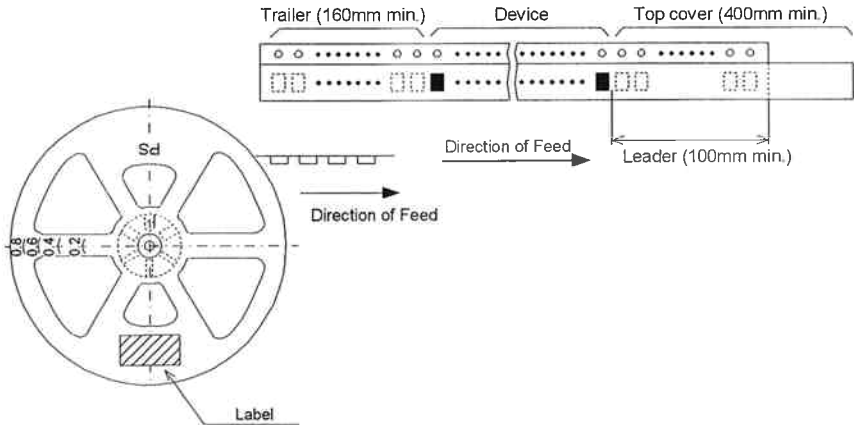

<Precautions>

- This product is for being used in general electric equipments (business equipments, telecommunication equipments and measurement equipments).
May not be used in medical equipments, nuclear equipments and trains which would affect lives or properties directly by the failure of this product.
- Do not remodel, process or use in a non-standard, it may cause serious accidents. We can not take responsibility for those products used in a wrong way or in a non-standard.
- When there is a problem, an excessive voltage may occur to the output and cause voltage decrease. Built-in a protection circuit (over-voltage protection, over-current protection etc.) assuming to have problems of malfunction and damage of equipments.
- Always keep the standards (input voltage, operating temperature and so on), without fail and be sure to insert a protection element to the input line. Also, always confirm each polarity (input and output) that there is no miss wiring before energizing. <<Wrong way of using will cause smoke fire.>>
- This product does not have a built-in over-voltage protection. When over-voltage occurs due to the abnormality in the module, there is a mode that input voltage comes out at it is, and may cause smoke and ignition. To prevent this, be sure to add over-voltage protection.
<<When over-voltage occurs, the remote ON/ OFF pin of this IC do not function .>>
- The contents specified herein are accurate and reliable, however we shall not take any responsibilities for any damages and loss or infringement of patent and any other rights, as a result of using these materials.
- This material does not guarantee the execution of patent or other rights of third party or approve the right of execution hereof.
- Reprinting and copying these materials are not allowed partially or totally without our prior written approval.

Export regulations for stragety goods

- Classified into integrated circuits, in the export regulations 1-7 section of the attached table, and the ordinance of the Ministry of Economy, Trade and Industry clause 6.
- This product is a subject for KNOW regulation.

Bellnix®

Bellnix Co., Ltd.

5-7-8 Negishi Minami-ku Saitama-shi, Saitama Japan 336-0024

Tel: +81-48-864-7733 Fax: +81-48-861-6402

E-mail: info@bellnix.co.jp

URL <http://www.bellnix.co.jp/>

All specifications are subject to change without notice.

PRINTED IN JAPAN BDD20050412-021203A

