

> **Features**

- High Current
- Low On-Resistance
- No Secondary Breakdown
- Low Driving Power
- High Forward Transconductance

> **Applications**

- Motor Control
- General Purpose Power Amplifier
- DC-DC converters

> **Outline Drawing**

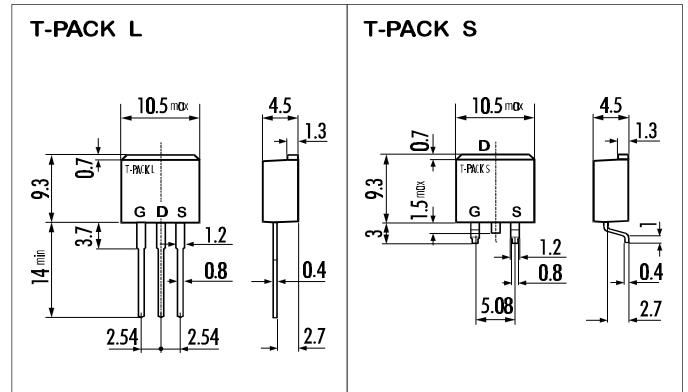

> **Maximum Ratings and Characteristics**

- Absolute Maximum Ratings ( $T_C=25^\circ\text{C}$ ), unless otherwise specified

Item	Symbol	Rating	Unit
Drain-Source-Voltage	$V_{DS}$	30	V
Drain-Gate-Voltage ( $R_{GS}=20\text{K}\Omega$ )	$V_{DGR}$	30	V
Continuous Drain Current	$I_D$	50	A
Pulsed Drain Current	$I_{D(puls)}$	200	A
Gate-Source-Voltage	$V_{GS}$	$\pm 16$	V
Max. Power Dissipation	$P_D$	80	W
Operating and Storage Temperature Range	$T_{ch}$	150	$^\circ\text{C}$
	$T_{stg}$	-55 ~ +150	$^\circ\text{C}$

> **Equivalent Circuit**

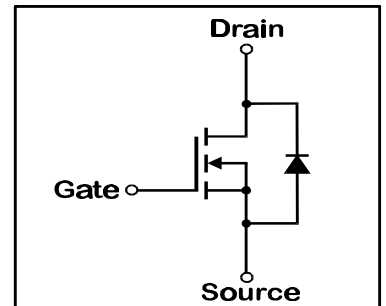

- Electrical Characteristics ( $T_C=25^\circ\text{C}$ ), unless otherwise specified

Item	Symbol	Test conditions	Min.	Typ.	Max.	Unit
Drain-Source Breakdown-Voltage	$V_{(BR)DSS}$	$I_D=1\text{mA}$ $V_{GS}=0\text{V}$	30			V
Gate Threshold Voltage	$V_{GS(th)}$	$I_D=1\text{mA}$ $V_{DS}=V_{GS}$	1,0	1,5	2,0	V
Zero Gate Voltage Drain Current	$I_{DSS}$	$V_{DS}=30\text{V}$ $T_{ch}=25^\circ\text{C}$		10	500	$\mu\text{A}$
		$V_{GS}=0\text{V}$ $T_{ch}=125^\circ\text{C}$		0,2	1,0	mA
Gate Source Leakage Current	$I_{GSS}$	$V_{GS}=\pm 16\text{V}$ $V_{DS}=0\text{V}$		10	100	nA
Drain Source On-State Resistance	$R_{DS(on)}$	$I_D=25\text{A}$ $V_{GS}=4\text{V}$		16	22	mΩ
		$I_D=25\text{A}$ $V_{GS}=10\text{V}$		10	13	mΩ
Forward Transconductance	$g_{fs}$	$I_D=25\text{A}$ $V_{DS}=12\text{V}$	17	35		S
Input Capacitance	$C_{iss}$	$V_{DS}=25\text{V}$		3500	5250	pF
Output Capacitance	$C_{oss}$	$V_{GS}=0\text{V}$		1650	2480	pF
Reverse Transfer Capacitance	$C_{rss}$	$f=1\text{MHz}$		830	1250	pF
Turn-On-Time $t_{on}$ ( $t_{on}=t_{d(on)}+t_r$ )	$t_{d(on)}$	$V_{CC}=12\text{V}$ $I_D=50\text{A}$		15	25	ns
				65	100	ns
Turn-Off-Time $t_{off}$ ( $t_{off}=t_{d(off)}+t_f$ )	$t_{d(off)}$	$V_{GS}=10\text{V}$ $R_{GS}=10\Omega$		190	290	ns
				140	210	ns
Avalanche capability	$I_{AV}$	$L=100\mu\text{H}$ $T_{ch}=25^\circ\text{C}$	50			A
Diode Forward On-Voltage	$V_{SD}$	$I_F=2I_{DR}$ $V_{GS}=0\text{V}$ $T_{ch}=25^\circ\text{C}$		1,25	1,80	V
Reverse Recovery Time	$t_{rr}$	$I_F=I_{DR}$ $V_{GS}=0\text{V}$		60		ns
Reverse Recovery Charge	$Q_{rr}$	$-di_F/dt=100\text{A}/\mu\text{s}$ $T_{ch}=25^\circ\text{C}$		70		$\mu\text{C}$

- Thermal Characteristics

Item	Symbol	Test conditions	Min.	Typ.	Max.	Unit
Thermal Resistance	$R_{th(ch-a)}$	channel to air			125	$^\circ\text{C}/\text{W}$
	$R_{th(ch-c)}$	channel to case			1,56	$^\circ\text{C}/\text{W}$

N-channel MOS-FET			
30V	13μΩ	50A	80W

# 2SK2516-01L,S

## FAP-III Series



### > Characteristics

Typical Output Characteristics

$I_D=f(V_{DS})$ ; 80μs pulse test;  $T_C=25^\circ\text{C}$

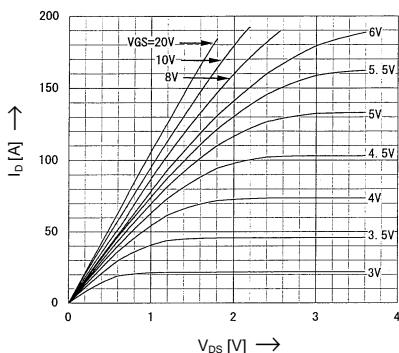

Drain-Source On-State Resistance

$R_{DS(on)}=f(T_{ch})$ ;  $I_D=25\text{A}$ ;  $V_{GS}=10\text{V}$

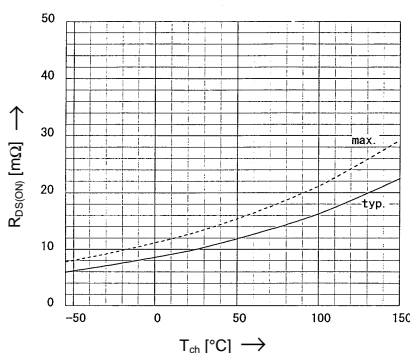

Typical Transfer Characteristics

$I_D=f(V_{GS})$ ; 80μs pulse test;  $V_{DS}=25\text{V}$ ;  $T_{ch}=25^\circ\text{C}$

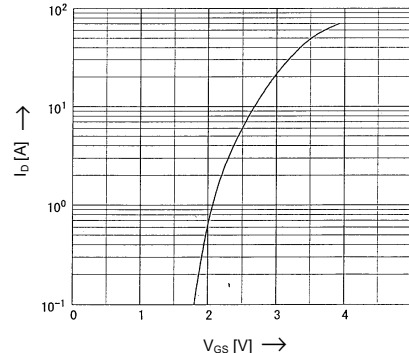

Typical Drain-Source On-State-Resistance

$R_{DS(on)}=f(I_D)$ ; 80μs pulse test;  $T_C=25^\circ\text{C}$

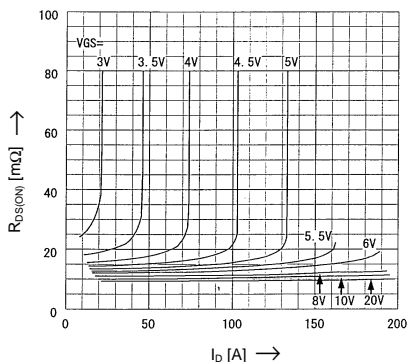

Typical Forward Transconductance

$g_{fs}=f(I_D)$ ; 80μs pulse test;  $V_{DS}=25\text{V}$ ;  $T_{ch}=25^\circ\text{C}$

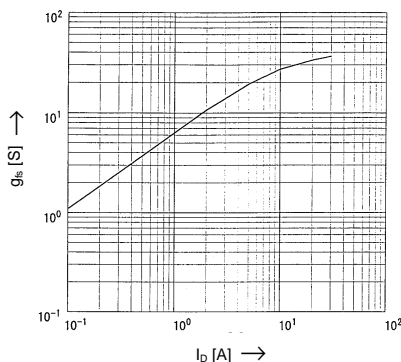

Gate Threshold Voltage vs.  $T_{ch}$

$V_{GS(th)}=f(T_{ch})$ ;  $I_D=1\text{mA}$ ;  $V_{DS}=V_{GS}$

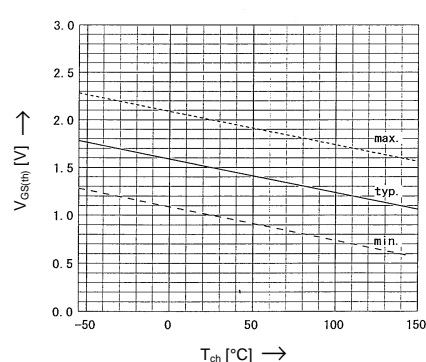

Typical Capacitances

$C=f(V_{DS})$ ;  $V_{GS}=0\text{V}$ ;  $f=1\text{MHz}$

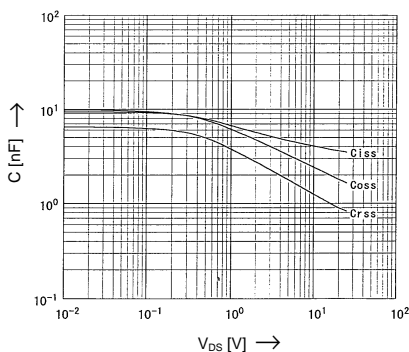

Typical Gate Charge Characteristics

$V_{GS}=f(Q_g)$ ;  $I_D=50\text{A}$ ;  $T_C=25^\circ\text{C}$

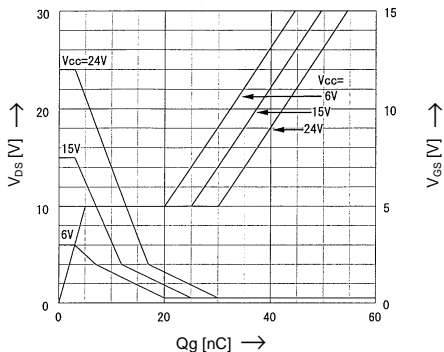

Forward Characteristics of Reverse Diode

$I_F=f(V_{SD})$ ; 80μs pulse test;  $V_{GS}=0\text{V}$

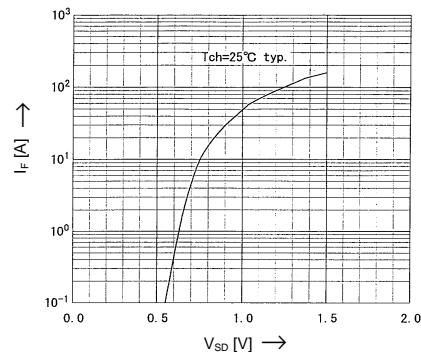

Power Dissipation

$P_D=f(T_C)$

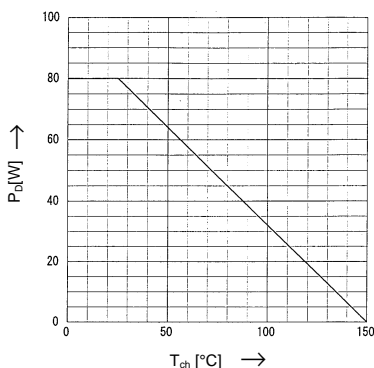

Safe Operation Area

$I_D=f(V_{DS})$ ;  $D=0.01$ ;  $T_C=25^\circ\text{C}$

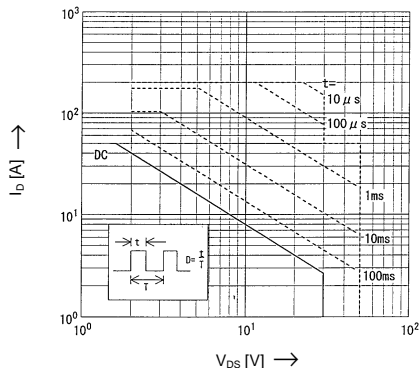

Transient Thermal Impedance

Transient Thermal impedance

$Z_{th(ch-c)}=f(t)$  parameter:  $D=t/T$

