

## STEERING DIODE ARRAY

**APPLICATIONS**

- ✓ Ethernet - 10/100/1000 Base T
- ✓ Cellular Phones
- ✓ Handheld Electronics
- ✓ FireWire
- ✓ USB Interface

**IEC COMPATIBILITY (EN61000-4)**

- ✓ 61000-4-2 (ESD): Air - 15kV, Contact - 8kV
- ✓ 61000-4-4 (EFT): 40A - 5/50ns
- ✓ 61000-4-5 (Surge): 12A, 8/20 $\mu$ s - Level 1(Line-Gnd) & Level 2(Line-Line)

**FEATURES**

- ✓ ESD Protection > 40 kilovolts
- ✓ Provides 14 Lines of Protection
- ✓ **LOW LEAKAGE CURRENT < 20nA**
- ✓ **ULTRA LOW CAPACITANCE: 3pF Typical**

**MECHANICAL CHARACTERISTICS**

- ✓ Molded JEDEC SO-16
- ✓ Weight 0.15 grams (Approximate)
- ✓ Flammability rating UL 94V-0
- ✓ 16mm Tape and Reel Per EIA Standard 481
- ✓ Marking: Part Number, Logo, Date Code & Pin One Defined By Dot on Top of Package

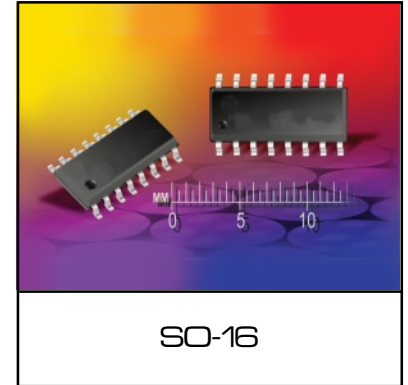
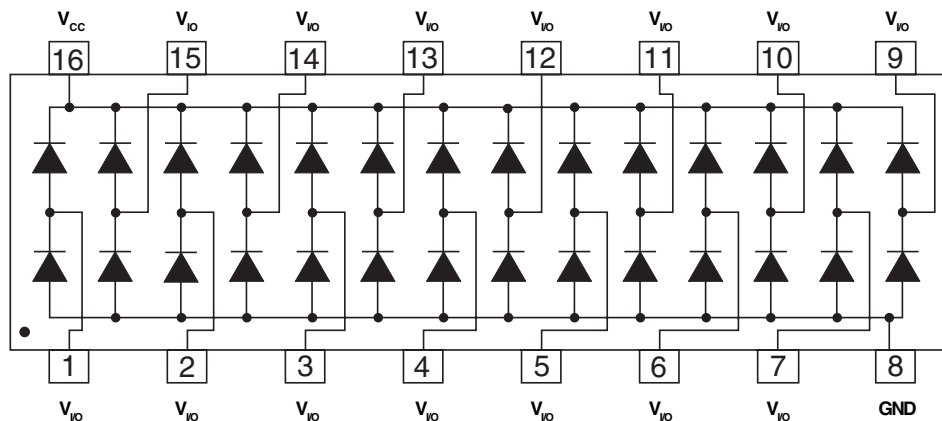
**PIN CONFIGURATION**

DEVICE CHARACTERISTICS

MAXIMUM RATINGS @ 25°C Unless Otherwise Specified			
PARAMETER	SYMBOL	VALUE	UNITS
Operating Temperature	$T_J$	-55°C to 150°C	°C
Storage Temperature	$T_{STG}$	-55°C to 150°C	°C
Continuous Power Dissipation	$P_{PC}$	145	mW

ELECTRICAL CHARACTERISTICS PER LINE @ 25°C Unless Otherwise Specified							
PART NUMBER	DEVICE MARKING	REPETITIVE PEAK REVERSE VOLTAGE (See Note 1)	TYPICAL FORWARD VOLTAGE	MAXIMUM PEAK PULSE FORWARD CURRENT	MAXIMUM REVERSE LEAKAGE CURRENT	MAXIMUM QUIESCENT SUPPLY CURRENT	TYPICAL CAPACITANCE (See Note 2)
		$V_{RRM}$ VOLTS	8/20µs @1A $V_F$ VOLTS	8/20µs $I_{FM}$ AMPS	$V_{RRM}$ @20V $I_R$ nA	@20V $I_{RQ}$ nA	@0V, 1 MHz $C_j$ pF
ET720	ET720	30	2	12	20	200	3

Note 1:  $V_{RRM}$  is  $+V_{CC}$  for pin 16,  $-V_{EE}$  for pin 1.

Note 2: Measure  $C_j$  between any  $V_{IO}$  pins to ground and divide by 2.

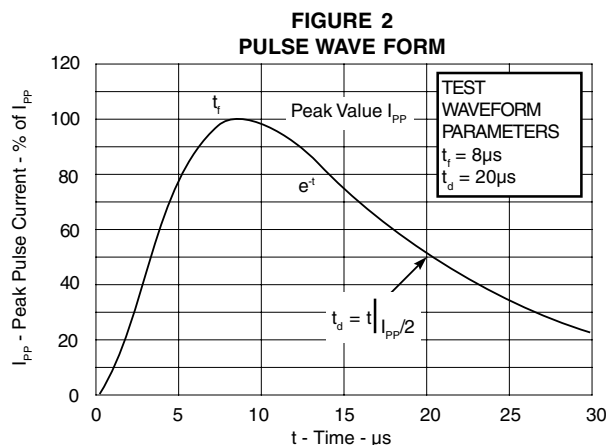
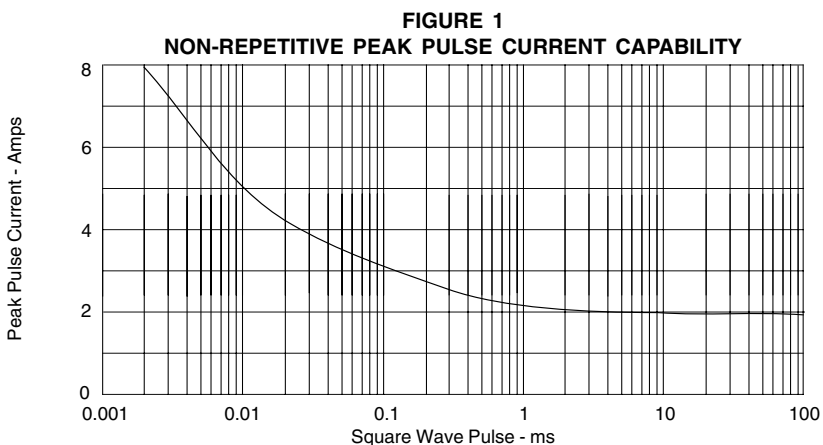

GRAPHS

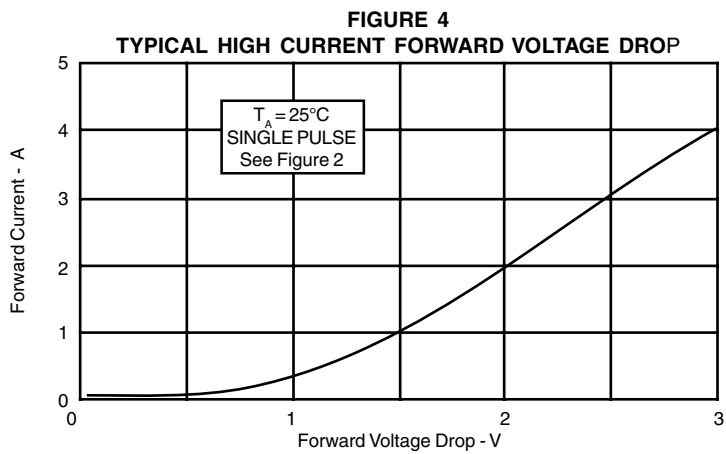
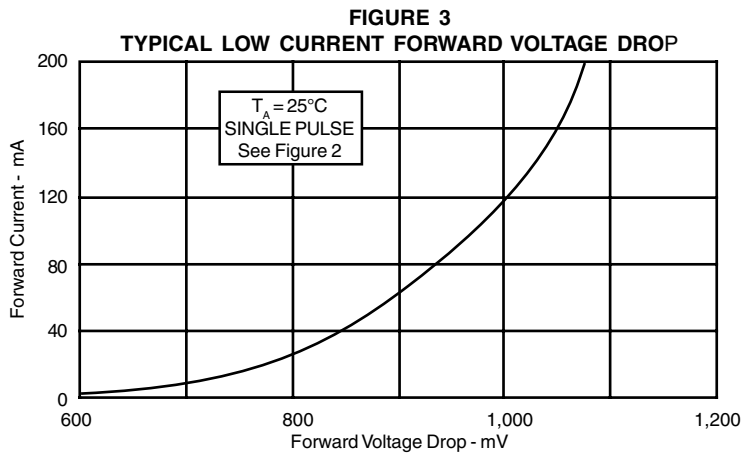

PACKAGE OUTLINE & DIMENSIONS

### PACKAGE OUTLINE

### SO-16

### PACKAGE DIMENSIONS

DIM	MILLIMETERS		INCHES	
	MIN	MAX	MIN	MAX
A	9.80	10.00	0.386	0.393
B	3.80	4.00	0.150	0.157
C	1.35	1.75	0.054	0.068
D	0.35	0.49	0.014	0.019
F	0.40	1.25	0.016	0.049
G	1.27 BSC	1.27 BSC	0.05 BSC	0.05 BSC
J	0.19	0.25	0.008	0.009
K	0.10	0.25	0.004	0.009
P	5.80	6.20	0.229	0.244
R	0.25	0.50	0.010	0.019

### MOUNTING PAD

### NOTES

- T = Seating Plane and Datum Surface.
- Dimensions "A" and "B" are Datum.
- Dimensions "A" and "B" do not include mold protrusions.
- Maximum mold protrusion is 0.015" (0.380 mm) per side.
- Dimensioning and tolerances per ANSI Y14.5M, 1982.
- Dimensions are exclusive of mold flash and metal burrs.

### TAPE & REEL/BULK ORDERING NOMENCLATURE

- Surface mount product is taped and reeled in accordance with EIA-481.
- Suffix-T7 = 7 Inch Reel - 1,000 pieces per 16mm tape, i.e., ET720-T7.
- Suffix-T13 = 13 Inch Reel - 2,500 pieces per 16mm tape, i.e., ET720-T13.
- No Suffix = Product Shipped in Tubes of 37 pcs per Tube.

**Outline & Dimensions: Rev 1 - 11/01, 06007**

COPYRIGHT © ProTek Devices 2003

SPECIFICATIONS: ProTek reserves the right to change the electrical and or mechanical characteristics described herein without notice (except JEDEC).

DESIGN CHANGES: ProTek reserves the right to discontinue product lines without notice, and that the final judgement concerning selection and specifications is the buyer's and that in furnishing engineering and technical assistance, ProTek assumes no responsibility with respect to the selection or specifications of such products.

**ProTek Devices**  
 2929 South Fair Lane, Tempe, AZ 85282  
 Tel: 602-431-8101 Fax: 602-431-2288  
 E-Mail: [sales@protekdevices.com](mailto:sales@protekdevices.com)  
 Web Site: [www.protekdevices.com](http://www.protekdevices.com)