

AZ DISPLAYS, INC.

COMPLETE LCD SOLUTIONS

SPECIFICATIONS FOR LIQUID CRYSTAL DISPLAY

PART NUMBER:

AGM3224K

REVISED:

NOVEMBER 11, 2002

AZ DISPLAYS, INC.

1. MECHANICAL DATA

(1) Product No.	AGM3224K
(2) Module Size	88.3 (W)mm X 69.1 (H)mm X 2.2MAX (D)mm
(3) Dot Size	0.225 (W)mm X 0.225 (H)mm
(4) Dot Pitch	0.24 (W)mm X 0.24 (H)mm
(5) Number of Dots	320 (W) X 240 (H) Dots
(6) Duty	1/240
(7) LCD Display Mode	FSTN: <input type="checkbox"/> Black and White(Normally White/Positive Image) Rear Polarizer: <input type="checkbox"/> Transflective
(8) Viewing Direction	9 O'clock
(9) Backlight	W/O
(10) Weight	24.5 g(Approx)
(11) Controller	Excluded
(12) DC/DC Converter	Excluded

2. ABSOLUTE MAXIMUM RATINGS

(1) ELECTRICAL ABSOLUTE RATINGS

GND=0V

ITEM	SYMBOL	MIN	MAX	UNIT	COMMENT
Power Supply for Logic	VDD-GND	-0.3	7.0	V	
Power Supply for LC Drive	VLCD-GND	-0.3	36.0	V	
Input Voltage	VI	-0.3	VDD+0.3	V	
Static Electricity	-	-	-	-	Note 1

(2) ENVIRONMENTAL ABSOLUTE MAXIMUM RATINGS

ITEM	WIDE TEMP.			
	OPERATING		STORAGE	
	MIN.	MAX.	MIN.	MAX.
Ambient Temperature	-20	70	-30	80
Humidity(Without Condensation)	Note 2,3		Note 2,4	

Note 1 LCM should be grounded during handling

Note 2 Background color will change slightly depending on ambient temperature.
This phenomenon is reversible.

Note 3 $T_a \leq 70^\circ\text{C}$: 75%RH max
 $T_a > 70^\circ\text{C}$: Absolute humidity must be lower
 than the humidity of 75%RH at 70°C

Note 4 T_a at -30°C will be $< 48\text{hrs}$, at 80°C will be $< 120\text{hrs}$

3. ELECTRICAL CHARACTERISTICS

(VDD = 3.0V ± 10%)

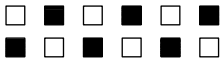
ITEM	SYMBOL	CONDITION	MIN.	TYP.	MAX.	UNIT	
Input Voltage	VIH	H level	0.8VDD	—	VDD	V	
	VIO	L level	0	—	0.2VDD	V	
Recommended LC Driving Voltage (WIDE TEMP. LCM)	VLCD-GND (Vop)	1/240 Duty	-20°C	17.3	17.5	17.7	V
			0°C	15.7	15.9	16.1	
		1/12 Bias	25°C	15.2	15.4	15.6	
			50°C	14.4	14.6	14.8	
			70°C	13.5	13.7	13.9	
Power Supply Current	IDD	VDD=3.0V GND=0V VDD-GND=22.7V FLM=70Hz	—	0.1	0.3	mA	
	ILCD	PATTERN : 	—	0.55	1.0		

4. OPTICAL CHARACTERISTICS

AT Vop

ITEM		Cr(Contrast Ratio)										θ (Viewing Angle)		ϕ (Viewing Angle)	
		-20°C		-0°C		25°C		50°C		70°C		25°C		25°C	
MODE		MIN.	TYP.	MIN.	TYP.	MIN.	TYP.	MIN.	TYP.	MIN.	TYP.	MIN.	TYP.	MIN.	TYP.
Z	T	2.5	3.0	3.5	4.0	5.0	5.5	3.0	3.5	2.0	2.5	-	F: 30 R: 25	-	±30
note		NOTE 6										NOTE 5			

NOTE :

Z: OTHER

T: NORMALLY WHITE(9 O'clock)

AT $\phi=0^\circ$ $\theta=0^\circ$

ITEM	SYMBOL	CONDITION	MIN.	TYP.	MAX.	UNIT	NOTE
Response Time (rise)	Tr	-20°C	5200	6700	10000	ms	NOTE 2
		0°C	950	1200	1800		
		25°C	280	350	500		
		50°C	130	160	250		
		70°C	80	100	150		
Response Time (fall)	Tf	-20°C	3400	4300	6500	ms	NOTE 2
		0°C	550	700	1000		
		25°C	200	250	350		
		50°C	70	90	140		
		70°C	50	70	110		

(NOTE 1)

Definition of Operation Voltage(V_{op})

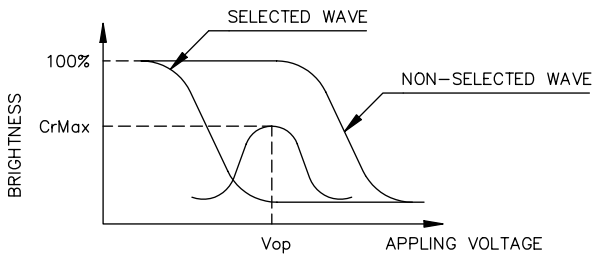

(positive type)

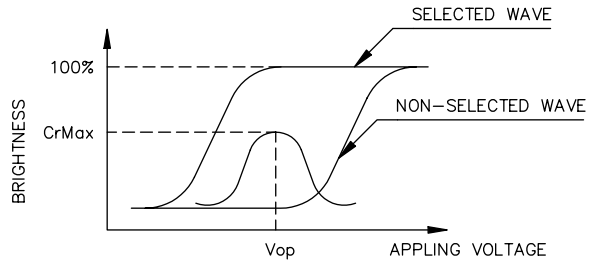

(negative type)

*Conditions

- Viewing Angle : 0
- Frame Frequency : 70Hz
- Applying Waveform : 1/N duty 1/a bias

(NOTE 2)

Definition of Response Time(T_r, T_f)

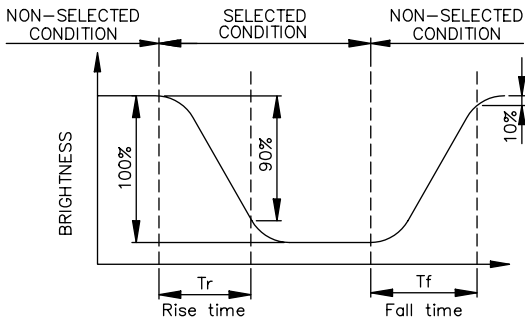

(positive type)

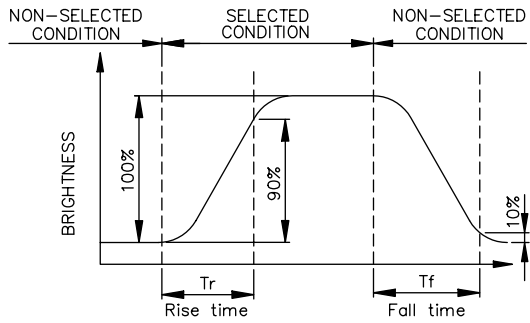

(negative type)

*Conditions

- Operating Voltage : V_{op}
- Viewing Angle (θ, ϕ) : (0,0)
- Frame Frequency : 70Hz
- Applying Waveform : 1/N duty 1/a bias

(NOTE 3)

Description of Measuring Equipment and Driving Waveforms

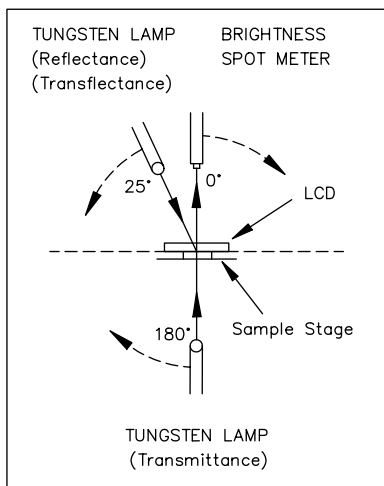

CONST.
TEMP.
CHAMBER

Multiplex Driving (1/N duty 1/a bias)

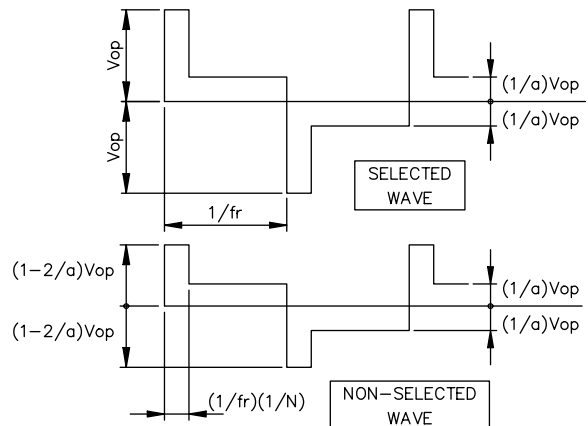

(NOTE 4)

Definition of Viewing Direction

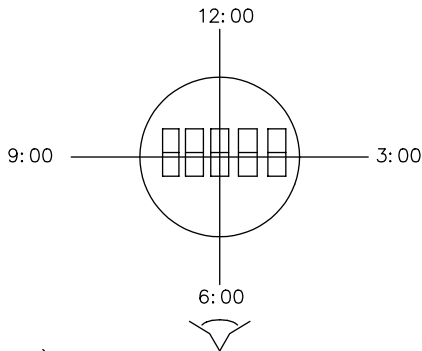

(NOTE 5)

Definition of Viewing Angle

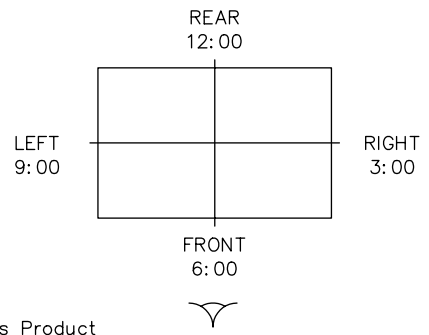
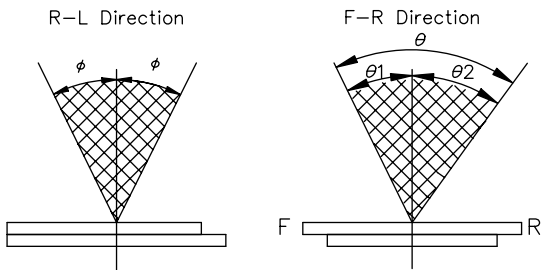

*For This Product
The Viewing Direction Is 6 O'clock
So $\theta_1 > \theta_2$

$$\theta = \theta_1 + \theta_2$$

*Conditions

Operating Voltage : V_{op}
Frame Frequency : 70Hz
Applying Waveform : 1/N duty 1/a bias
Contrast Ratio : larger than 2

(NOTE 6)

Definition of Contrast Ratio (Cr)

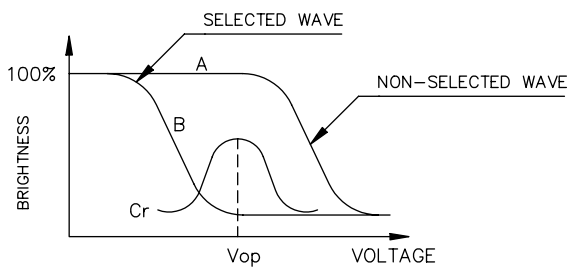

(positive type)

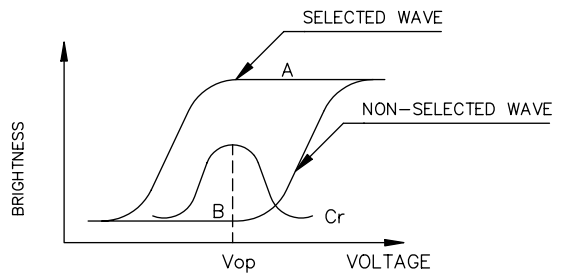

(negative type)

$$\text{Contrast Ratio : } Cr = A/B$$

*Conditions

Viewing Angle : 0
Frame Frequency : 70Hz
Applying Waveform : 1/N duty 1/a bias

5. BLOCK DIAGRAM

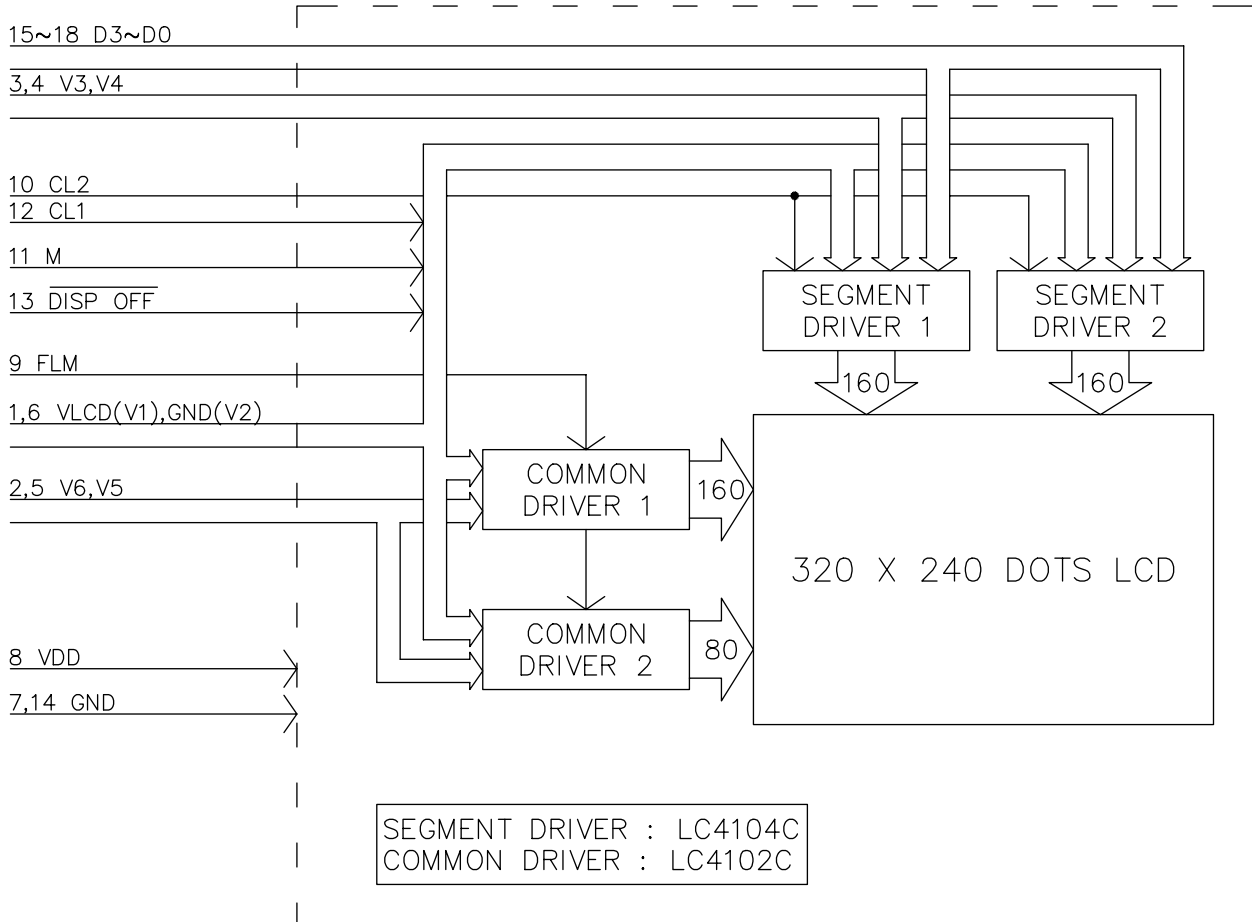

Note :

- 1) Controller and bias voltage supply circuit are not included.
- 2) VLCD(V1),GND(V2),V6,V3,V4 and V5 are power supply voltage for LCD.
(V1>V6>V3>V4>V5>V2)

6. INTERNAL PIN CONNECTION

PIN NO.	SYMBOL	FUNCTION
1	VLCD(V1)	Bias voltage(Liquid crystal drive voltage)
2	V6	Bias voltage(V1>V6>V3>V4>V5>V2)
3	V3	
4	V4	
5	V5	
6	GND(V2)	(GND: 0V)
7	GND	0V
8	VDD	Power supply voltage: +3.0V typ
9	FLM	Frame signal
10	CL2	Display data shift clock
11	M	LCD drive signal(AC signal)
12	CL1	Display data latch signal
13	$\overline{\text{DISP OFF}}$	Display ON/OFF control signal("H": Display ON, "L": Display OFF)
14	GND	0V
15	D3	Display data
16	D2	
17	D1	
18	D0	

7. POWER SUPPLY

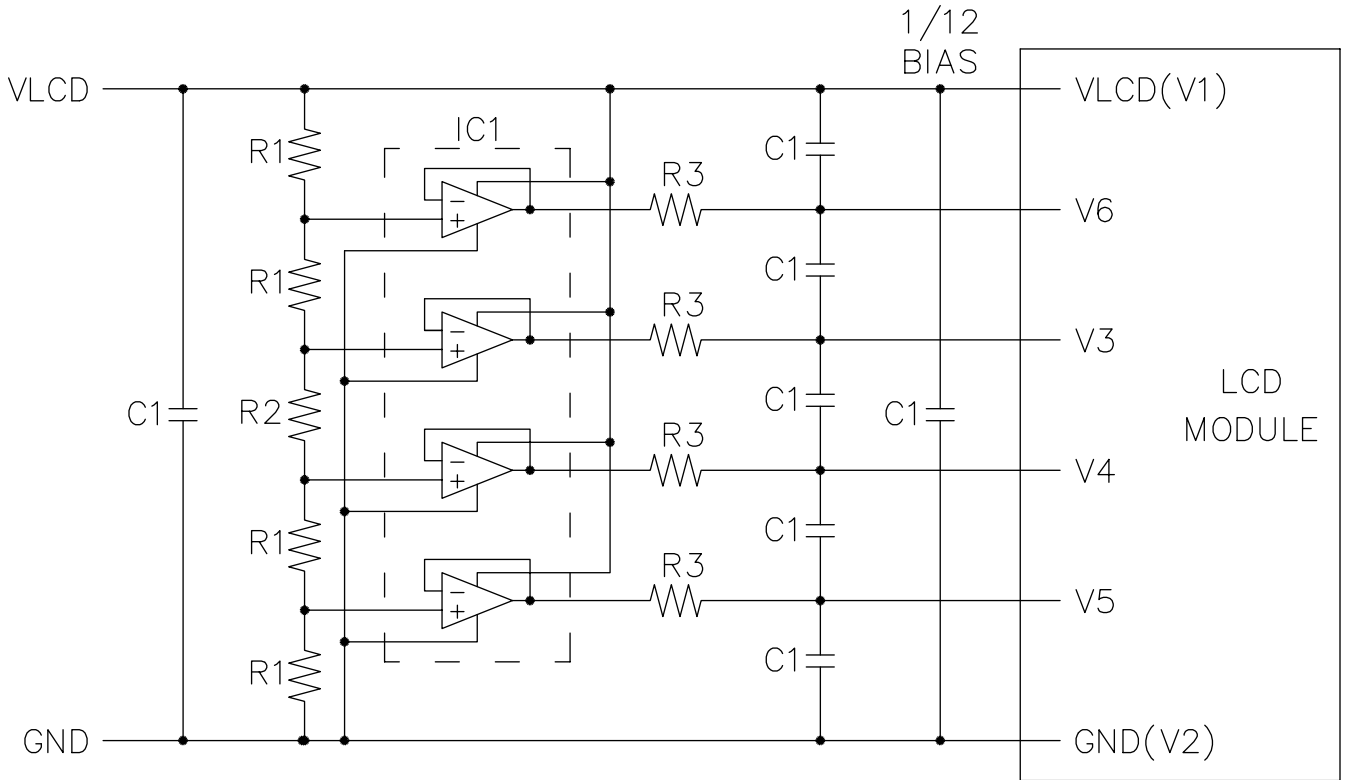

IC1 : LP324M(NATIONAL SEMICONDUCTOR)
 R1 : 22(KOHM) \pm 0.5%, R2 : 180(KOHM) \pm 2%, R3 : 4.7(OHM) \pm 5%
 C1 : 2.2-4.7(uF)

8. TIMING CHARACTERISTICS

8-1. INTERFACE TIMING

@ VDD=3.0V±10%, Ta=-20~70 °C

Item	Symbol	Test condition	Min.	Typ.	Max.	Unit
CL2 Cycle Time	tC	Fig.a	82	-	-	ns
CL2 Pulse Width	tSWH,tSWL	Fig.a	28	-	-	ns
CL2 Rise/Fall Time	tCR,tCF	Fig.a	-	-	50	ns
Data Set Up Time	tDSU	Fig.a , Fig.b	100	-	-	ns
Data Hold Time	tDHD	Fig.a , Fig.b	30	-	-	ns
CL1 Cycle Time	tL	Fig.b	250	-	-	ns
CL1 "H" Pulse Width	tLWH	Fig.a , Fig.b	100	-	-	ns
CL1 Rise/Fall Time	tLR,tLF	Fig.b	-	-	30	ns
CL2 To CL1 Delay Time	tCL	Fig.a	30	-	-	ns
CL1 To CL2 Delay Time	tLC	Fig.a	-	-	200	ns
FLM TO CL1 SETUP TIME	tFLS	Fig.b	30	-	-	ns
FLM TO CL1 HOLD TIME	tFLH	Fig.b	50	-	-	ns

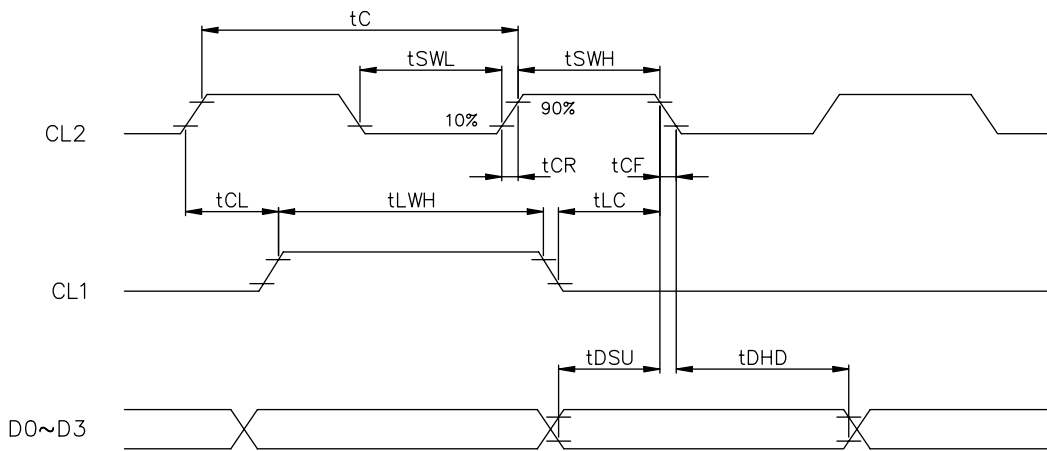

Fig . a Interface timing (SEGMENT)

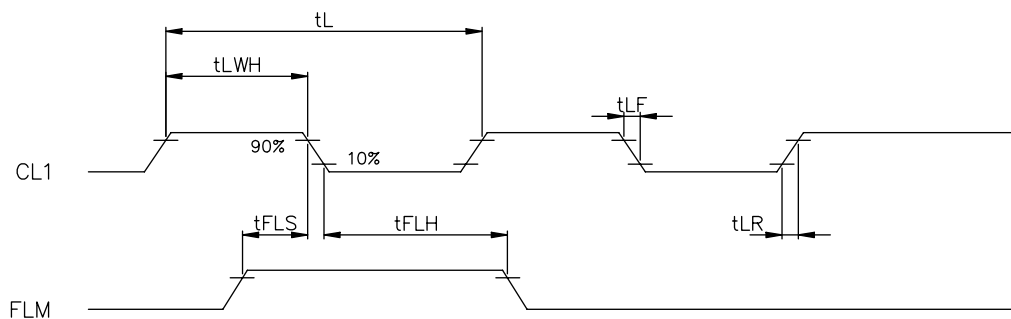
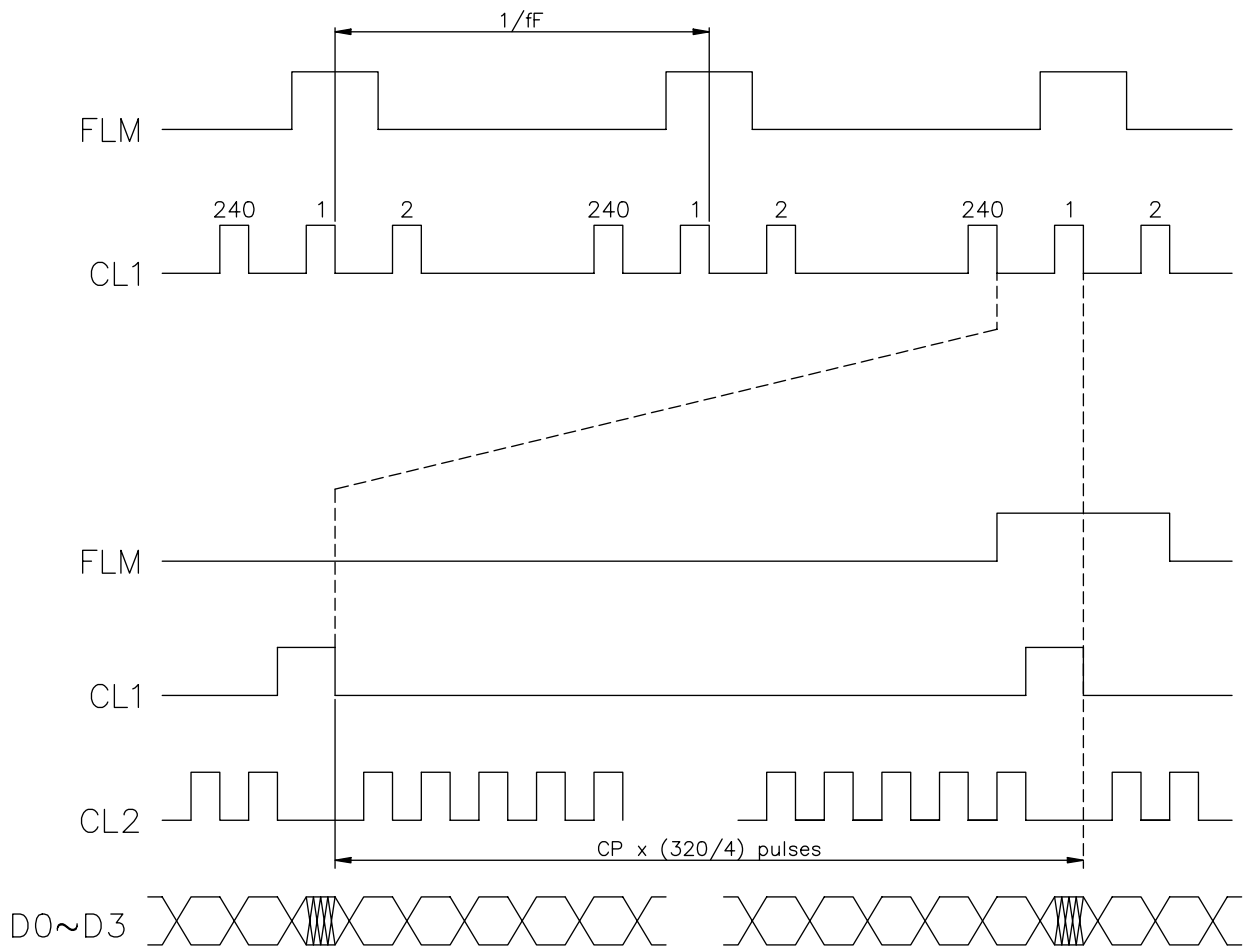
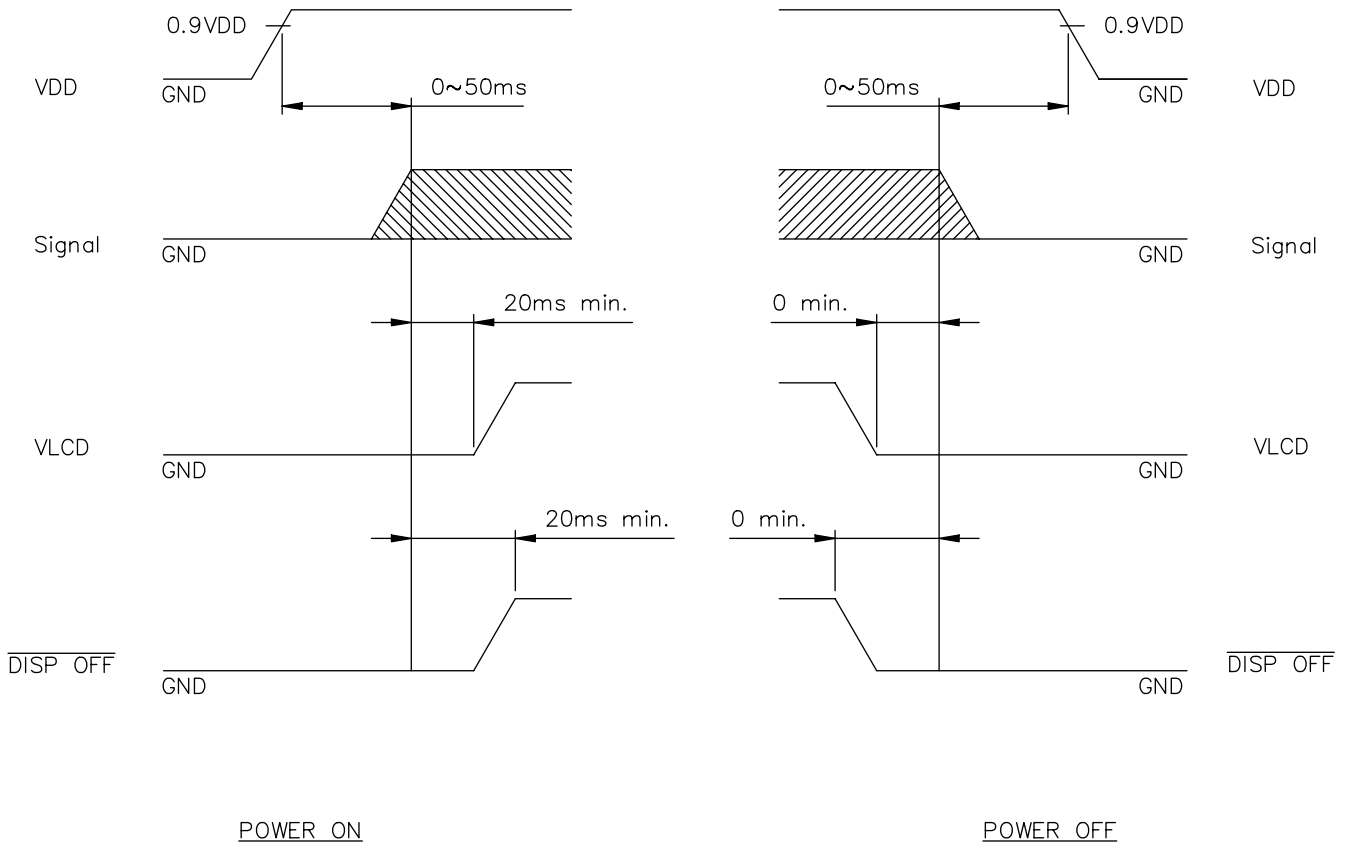

Fig . b Interface timing (COMMON)

8-2. TIMING CHART OF INPUT SIGNAL



8-3. POWER ON/OFF TIMING



Missing pixels may occur when the LCM is driven beyond the above power interface timing sequence.

8-4.DISPLAY PATTERN

	Column1	Column2	Column3	Column4	Column320
Row 1	1 • 1	1 • 2	1 • 3	1 • 4	1 • 320
Row 2	2 • 1	2 • 2	2 • 3		
Row 3	3 • 1	3 • 3			
	D0: (1 • 4) ↘ (1 • 8) • • • • • (240 • 320) D1: (1 • 3) ↘ (1 • 7) • • • • • (240 • 319) D2: (1 • 2) ↘ (1 • 6) • • • • • (240 • 318) D3: (1 • 1) ↘ (1 • 5) • • • • • (240 • 317)				
Row 240	240 • 1				240 • 320

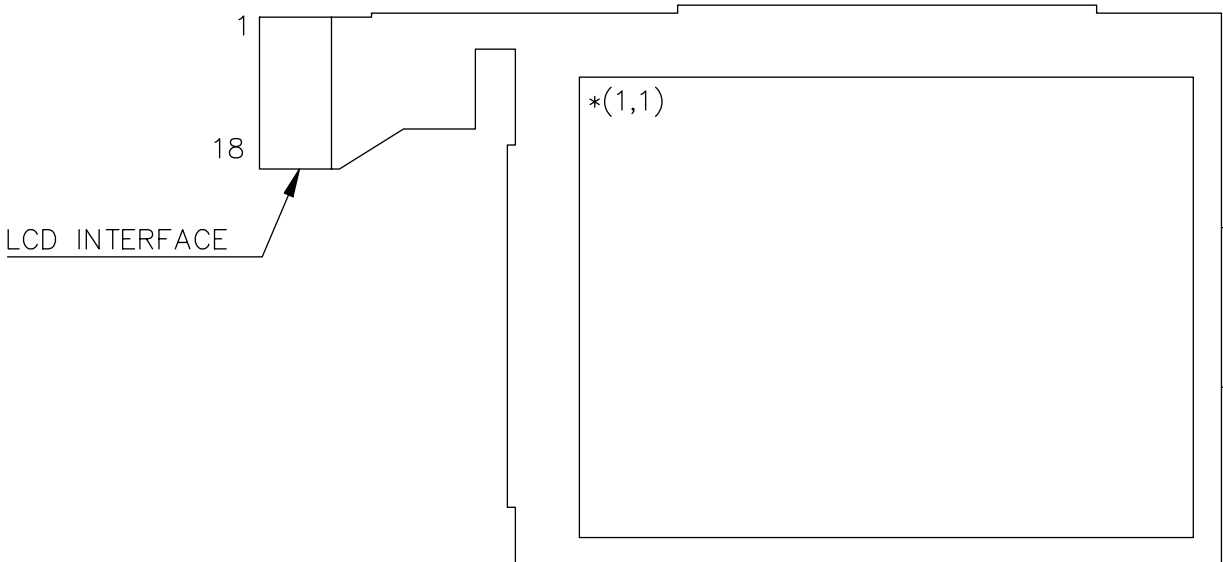

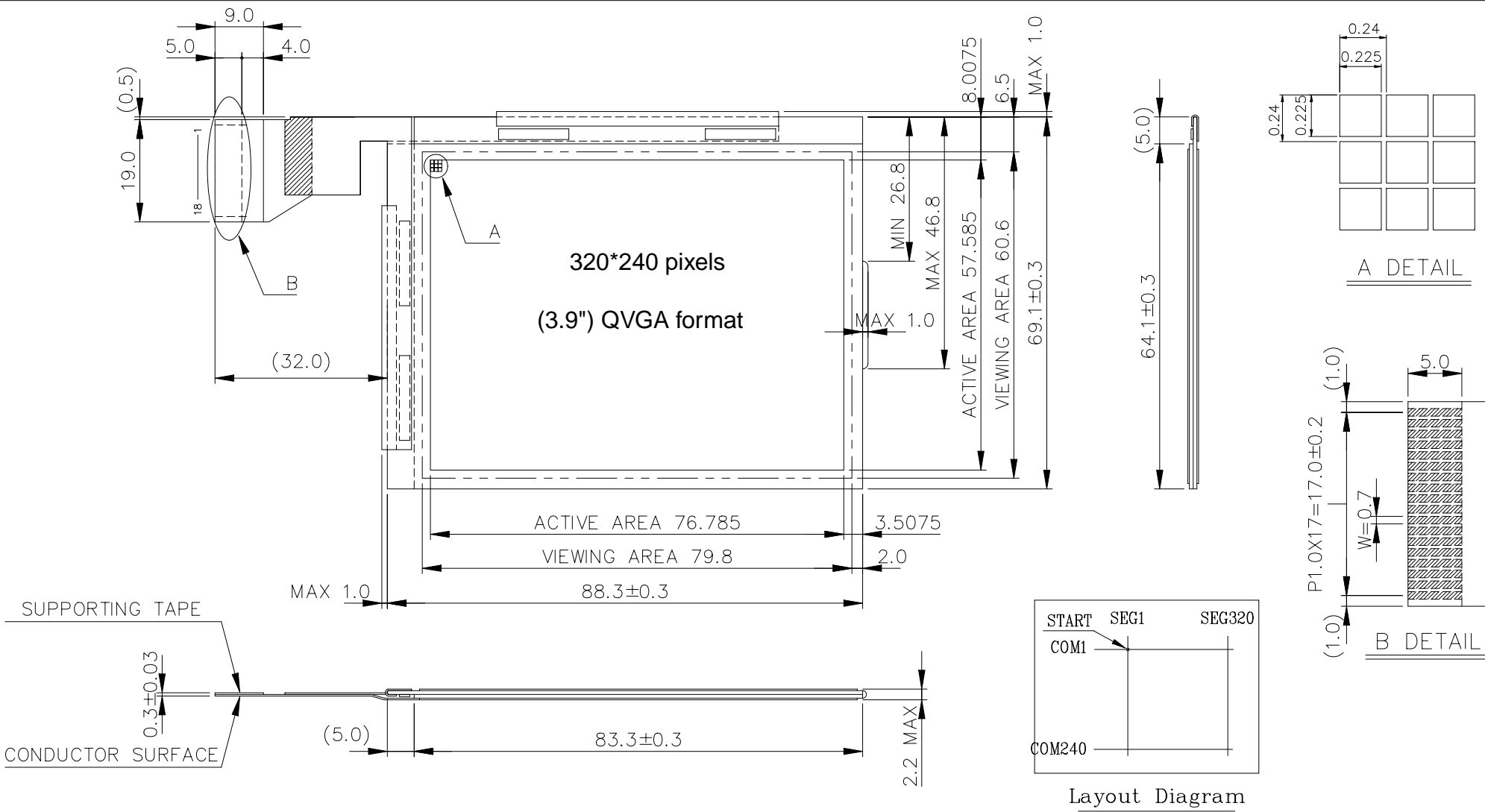

PIN NO	SYMBOL	FUNCTION	14	GND	0V
1	VLCD(V1)	Bias voltage(Liquid crystal drive voltage)	15	D3	Display data
2	V6		16	D2	
3	V3		17	D1	
4	V4		18	D0	
5	V5				
6	GND(V2)	(GND:0V)			
7	GND	0V			
8	VDD	Power supply voltage: +3.0V typ			
9	FLM	Frame signal(sync. Of display)			
10	CL2	Display data shift clock			
11	M	LCD drive signal(AC signal)			
12	CL1	Display data latch signal			
13	DISP OFF	Display ON/OFF control signal("H": Display ON,"L": Display OFF)			

Note:
 1. RESOLUTION : 320x240 DOTS.
 2. COG IC : COM LC4102C
 SEG LC4104C

DIMENSION	TOLERANCE
L ≦ 6	±0.25 (mm)
6 < L ≦ 18	±0.3 (mm)
18 < L ≦ 50	±0.4 (mm)
50 < L ≦ 125	±0.5 (mm)
125 < L	±0.6 (mm)
ANGLE	±1° (DEG)

AZ DISPLAYS, INC.

AGM3224K

NAME	DATE	THIRD ANGLE P.

REV. NO.	DESCRIPTION	DATE	DESIGN	CHECK	APPROVE
5					
4					
3					
2					
1					

APPROVE	CHECK	DESIGN	DRAWN	SCALE	UNIT
		J.Y.Lin	Ping Ping	89.05.16	89.05.16
				-	mm

DWG NO. M359-D0A