



RE46C100

Piezoelectric Horn Driver Circuit
Product Specification

General Description

This product is intended for applications using a self oscillating piezoelectric horn although it can be used in direct drive applications. Feedback control and a driver circuit are provided as well as a horn enable function.

Applications

Smoke detectors
CO Detectors
Personal Security Products
Electronic Toys

Features

- Low Quiescent Current (<100na)
- Low Driver Ron - 20Ω typical at 9V
- Wide Operating Voltage Range
- 8 Pin DIP and SO Packages
- Available in Standard Packaging or RoHS Compliant Pb Free Packaging

Pin Configuration

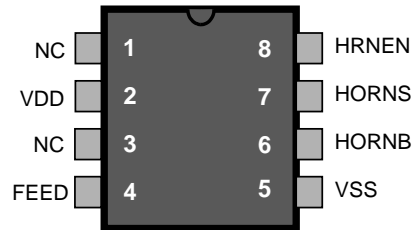

ABSOLUTE MAXIMUM RATINGS

PARAMETER	SYMBOL	VALUE	UNITS
Supply Voltage	V _{DD}	18	V
Input Voltage Range Except FEED	V _{in}	-.3 to V _{dd} +.3	V
FEED Input Voltage Range	V _{infd}	-10 to +22	V
Input Current except FEED	I _{in}	10	mA
Operating Temperature	T _A	-40 to 85	°C
Storage Temperature	T _{STG}	-55 to 125	°C
Maximum Junction Temperature	T _J	150	°C

Stresses beyond those listed under Absolute Maximum Ratings may cause permanent damage to the device. These are stress ratings only and operation at these conditions for extended periods may affect device reliability.

This product utilizes CMOS technology with static protection; however proper ESD prevention procedures should be used when handling this product. Damage can occur when exposed to extremely high static electrical charge.

RE46C100

Piezoelectric Horn Driver Circuit
Product Specification



R&E International

DC Electrical Characteristics at TA = 25°C, VDD=9V, Typical Application (unless otherwise noted)

Parameter	Symbol	Test Pin	Test Conditions	Limits			
				Min	Typ	Max	Units
Supply Voltage	V _{DD}	2	Operating	6	9	16	V
Supply Current	I _{DD1}	2	HRNEN and FEED=0V			100	nA
Input Voltage Low	V _{IL1}	8				1	V
Input Voltage High	V _{IH1}	8		2.3			V
Input Leakage Low	I _{IL1}	8	Vin=VSS			-100	nA
	I _{LFD}	4	FEED=-10V			-50	uA
Input Leakage High	I _{IH1}	8	Vin=VDD			100	nA
	I _{HFD}	4	FEED=22V			50	uA
Output Voltage Low	V _{OL1}	6,7	I _{ol} =16mA		.3	.5	V
	V _{OL2}	6,7	I _{ol} =16mA, VDD=7.2V			.9	V
Output Voltage High	V _{Oh1}	6,7	I _{oh} =-16mA	8.5	8.7		V
	V _{Oh2}	6,7	I _{oh} =-16mA, VDD=7.2V	6.3			V

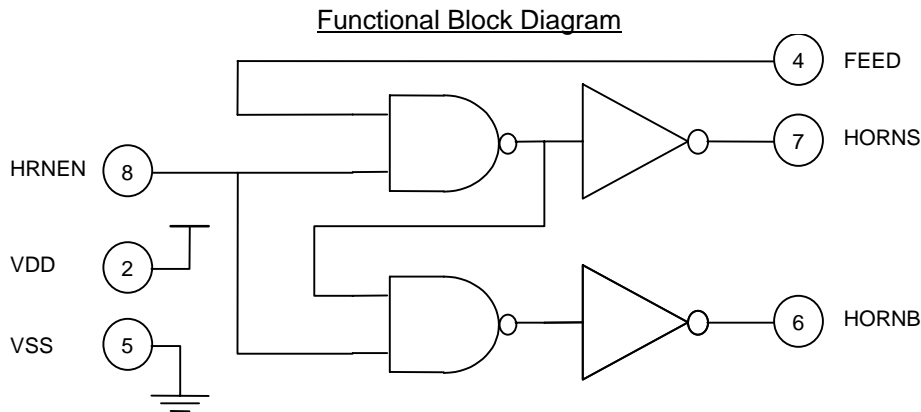

RE46C100

Piezoelectric Horn Driver Circuit
Product Specification



R&E International

Typical Application

