

## 1.2V to 3.6V Universal Bi-directional Level Shifter with Automatic Direction Control & Advanced Package Solution

### Features

- Designed for low voltage operation: 1.2V to 3.3V  $\pm 10\%$
- Universal bidirectional level shifting with automatic direction control
- Fast bus speeds up to 160 Mbps
- $I_{OFF}$  supports partial Power-Down mode operation
- Drive Capability 12mA
- Independent translation of each bit
- Each supply rail is configurable over supply range
- ESD Protection exceeds JESD22
  - 2000V Human Body Model (A114-B)
  - 200V Machine Model (A115-A)
- Latch-up performance exceeds 100mA per JESD 78
- Industrial operation at  $-40^{\circ}\text{C}$  to  $+85^{\circ}\text{C}$
- Packaging (Pb-free & Green):
  - 45 lead VFBGA (NL)

### Description

Pericom Semiconductor's PI4ULS3V16M is a 16-bit (dual-octal) non-inverting bus transceiver with two separate supply rails. A port ( $V_{CCA}$ ) and B port ( $V_{CCB}$ ) are set to operate at 1.4V to 3.6V. This arrangement permits universal bidirectional translation of differential signal levels over the voltage ranges.

PI4ULS3V16M is designed for asynchronous communication between data buses. Data is transmitted from the A bus to the B bus, or vice versa, without direction control. All  $A_X$  and  $B_X$  are tri-stated when data is coming from both directions at the same time. The output-enable ( $\overline{OE}$ ) input is used to disable outputs so buses are isolated.

The control pins, SEL, TEST\_EN and Out\_SEL are supplied by  $V_{CCB}$ .

The device is fully specified for partial power-down applications using  $I_{OFF}$ . The  $I_{OFF}$  circuitry disables the outputs, preventing damaging current backflow through the device when it is powered down.

To ensure the high-impedance state during power-up or power-down, the output-enable ( $\overline{OE}$ ) input should be tied to  $V_{CC}$  through a pullup resistor.

### Block Diagram

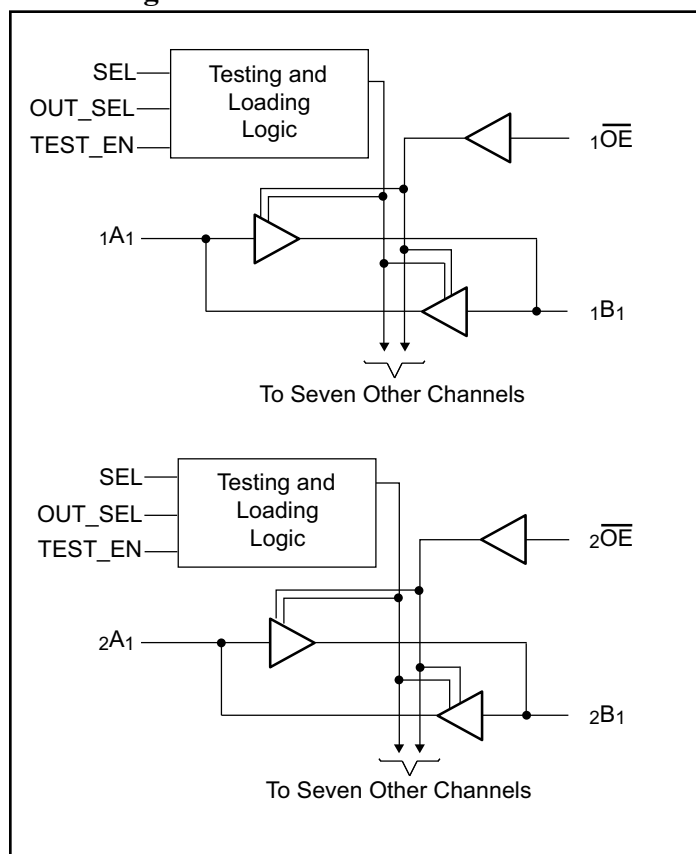

### Applications

- Voltage Translation
- Bus Relay
- Mobile Terminals

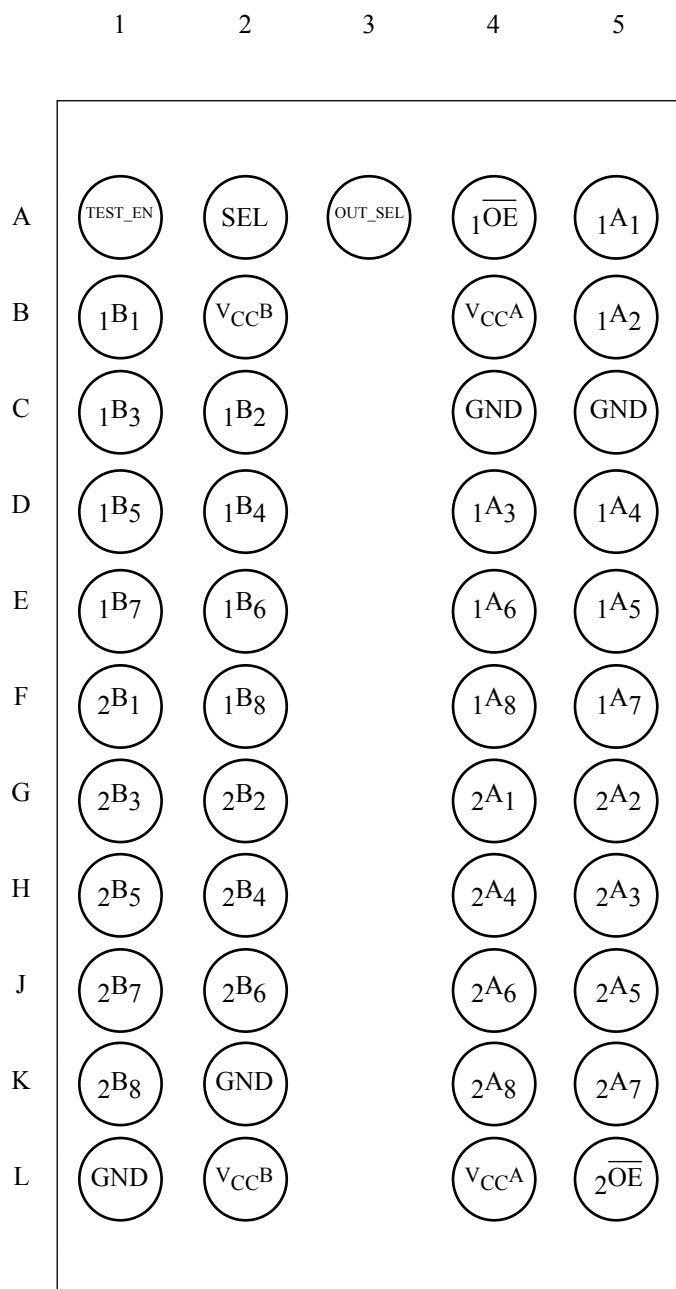
**Pin Configuration (Top View)**

### Maximum Ratings<sup>(3)</sup>

(Absolute maximum ratings over operating free-air temperature range, unless otherwise noted)

Supply voltage range: $V_{CCA}$ ..... -0.5V to 4.6V	Input clamp current, $I_{IK}$ ( $V_I < 0$ )..... -50mA
$V_{CCB}$ ..... -0.5V to 4.6V	Output clamp current, $I_{OK}$ ( $V_O < 0$ )..... -50mA
Input voltage range, $V_I$ <sup>(1)</sup> Control Inputs ..... -0.5V to 4.6V	Continuous output current, $I_O$ ..... $\pm 20$ mA
Voltage Range applied to any I/O pins in the high-impedance or Power-Off state, $V_{IO}$ <sup>(1)</sup> :	Continuous current through $V_{CCA}$ , $V_{CCB}$ or GND ..... $\pm 100$ mA
A Port ..... -0.5V to 4.6V	Storage temperature range, $T_{STG}$ ..... -65°C to 150°C
B Port..... -0.5V to 4.6V	
Voltage Range applied to any I/O pins in the High or Low state $V_{IO}$ <sup>(1, 2)</sup> :	
A Port ..... -0.5V to $V_{CCA} + 0.5$ V	
B Port..... -0.5V to $V_{CCB} + 0.5$ V	

**Notes:**

1. The input negative voltage and output voltage ratings may be exceeded if the input and output current ratings are observed.
2. This value is limited to 3.6V maximum.
3. Stresses greater than those listed under MAXIMUM RATINGS may cause permanent damage to the device. This is a stress rating only and functional operation of the device at these or any other conditions above those indicated in the operational sections of this specification is not implied. Exposure to absolute maximum rating conditions for extended periods may affect reliability.

### Pin Description

Pin Name	Description
$\overline{xOE}$	3-State Output Enable Inputs (Active LOW)
SEL	Outputs Loading Selection
$xAX$	Side A Inputs/Outputs
$xBX$	Side B Inputs/Outputs
TEST_EN	Enable Test Mode
OUT_SEL	Output Impedance Selection
GND	Ground
$V_{CCA}$ , $V_{CCB}$	Power

### Truth Table<sup>(1)</sup>

Inputs		Outputs Loading <sup>(2)</sup>	Operation
$\overline{xOE}$	SEL		
L	L	$C_L \leq 50$ pF	Bus B data to Bus A, or Bus A data to Bus B
L	H	$C_L \leq 30$ pF	
H	X		Z (Isolation)

**Notes:**

1. H = HIGH Signal Level  
L = LOW Signal Level  
X = Don't Care or Irrelevant  
Z = High Impedance
2. Refer to Figure 1 for Output Loading Chart

### Test Mode / Output Impedance Select

TEST_EN	Out_SEL	Condition
L	L	Normal Operation Low output impedance 300 $\Omega$
L	H	Normal Operation High output impedance 2.2K $\Omega$
H	L	Test_MODE A $\rightarrow$ B
H	H	Test_MODE B $\rightarrow$ A

**Recommended Operating Conditions<sup>(1, 2, 3)</sup>**

Parameter	Description		V <sub>CCI</sub>	Min.	Max.	Units
V <sub>CCA</sub> , V <sub>CCB</sub>	Supply Voltage			1.2	3.6	V
V <sub>IH</sub>	High-Level Input Voltage	I/O pins	1.2V to 1.95V	0.65 x V <sub>CCI</sub>		
			2.3V to 2.7V	1.7		
			2.7V to 3.6V	2		
V <sub>IL</sub>	Low-Level Input Voltage	I/O pins	1.2V to 1.95V		0.35 x V <sub>CCI</sub>	
			2.3V to 2.7V		0.7	
			2.7V to 3.6V		0.8	
V <sub>IHB</sub>	High-Level Input Voltage	Control Inputs (OE and SEL)	1.4V to 1.95V	0.65 x V <sub>CCB</sub>		
			2.3V to 2.7V	1.7		
			2.7V to 3.6V	2		
V <sub>ILB</sub>	Low-Level Input Voltage	Control Inputs (OE and SEL)	1.4V to 1.95V		0.35 x V <sub>CCB</sub>	
			2.3V to 2.7V		0.7	
			2.7V to 3.6V		0.8	
V <sub>I</sub>	Input Voltage	I/O pins and Control Inputs		0	3.6	
V <sub>O</sub>	Output Voltage	I/O pins and Control Inputs		0	3.6	
I <sub>OH</sub>	High-Level Output Current	I/O pins	V <sub>CCO</sub> = 1.2V		-3	
			V <sub>CCO</sub> = 1.4V		-5	
			V <sub>CCO</sub> = 1.65V		-8	
			V <sub>CCO</sub> = 2.3V		-9	
			V <sub>CCO</sub> = 3.0V		-12	
I <sub>OL</sub>	Low-Level Output Current	I/O pins	V <sub>CCO</sub> = 1.2V		-3	
			V <sub>CCO</sub> = 1.4V		5	
			V <sub>CCO</sub> = 1.65V		8	
			V <sub>CCO</sub> = 2.3V		9	
			V <sub>CCO</sub> = 3.0V		12	
ΔV/Δt	Input Transition rise or fall rate				10	V/ns
T <sub>A</sub>	Operating Free-Air Temperature			-40	85	°C

**Notes:**

1. V<sub>CCI</sub> is the V<sub>CC</sub> associated with the data input port.
2. V<sub>CCO</sub> is the V<sub>CC</sub> associated with the data output port.
3. To ensure proper device operation, all unused device inputs must be held at V<sub>CCI</sub> or GND.

**Electrical Characteristics for** (Over recommended free-air temperature range, unless otherwise noted.)<sup>(3)</sup>

Parameter	Description	Test Conditions	V <sub>CCA</sub> /V <sub>CCB</sub>	Min.	Typ. <sup>(1)</sup>	Max.	Units
V <sub>OH</sub>	High-Level Output Voltage	I <sub>OH</sub> = -100μA	1.2V to 3.6V	V <sub>CCO</sub> - 0.1V			V
		I <sub>OH</sub> = -2mA	1.2		0.8		
		I <sub>OH</sub> = -4mA	1.4	1			
		I <sub>OH</sub> = -7mA	1.65V	1.2			
		I <sub>OH</sub> = -9mA	2.3V	1.8			
		I <sub>OH</sub> = -12mA	3.0V	2.4			
V <sub>OL</sub>	Low-Level Output Voltage	I <sub>OL</sub> = 100μA	1.2V to 3.6V			0.2	V
		I <sub>OL</sub> = 2mA	1.2		0.1		
		I <sub>OL</sub> = 4mA	1.4			0.4	
		I <sub>OL</sub> = 7mA	1.65V			0.4	
		I <sub>OL</sub> = 9mA	2.3V			0.4	
		I <sub>OL</sub> = 12mA	3.0V			0.4	
I <sub>CC</sub>	Quiescent Supply Current	V <sub>I</sub> = V <sub>CCI</sub> or GND, I <sub>O</sub> = 0	1.2V to 3.6V			10	μA
I <sub>I</sub>	Control Inputs (OE and SEL)	V <sub>I</sub> = V <sub>CCB</sub> or GND	1.2V to 3.6V			±5	
I <sub>OZ</sub> <sup>(2)</sup>	3-State Output Current	V <sub>O</sub> = V <sub>CCO</sub> or GND	1.2V to 3.6V			±10	
I <sub>OFF</sub>	Power-off Leakage Current	V <sub>I</sub> or V <sub>O</sub> = 0 to 3.6V	0V			±10	
C <sub>IN</sub>	Control Input Capacitance	V <sub>I</sub> = V <sub>CCB</sub> or GND			3		pF
C <sub>IO</sub>	I/O Capacitance	V <sub>O</sub> = V <sub>CCA/B</sub> or GND			5		

**Notes:**

1. All typical values are at T<sub>A</sub> = 25°C.
2. For I/O ports, the parameter I<sub>OZ</sub> includes the input leakage current.
3. Parameters are specified under test mode conditions.

### Timing Characteristics for $V_{CCA} = 1.5V \pm 0.1V$

(Over recommended free-air temperature range, unless otherwise noted.)

Parameter	From (Input)	To (Output)	$V_{CCB} = 1.2V$	$V_{CCB} = 1.5V \pm 0.1V$		$V_{CCB} = 1.8V \pm 0.15V$		$V_{CCB} = 2.5V \pm 0.2V$		$V_{CCB} = 3.3V \pm 0.3V$		Units
			Typ	Min.	Max.	Min.	Max.	Min.	Max.	Min.	Max.	
$t_{PD}$	A	B	8	1.0	7.0	1.0	6.5	1.0	6.0	1.0	5.0	ns
	B	A	6	1.0	7.0	1.0	6.5	1.0	6.0	1.0	5.5	
$t_{SK(a)}^{(1)}$					0.3		0.3		0.3		0.3	
$t_{SK(b)}^{(1)}$					0.25		0.25		0.25		0.25	
$f_{max}$ 10pF load SEL='HIGH'	B	A	15	15		22		25		28		MHz
	A	B	14	15		18		18		20		

### Timing Characteristics for $V_{CCA} = 1.8V \pm 0.15V$

(Over recommended free-air temperature range, unless otherwise noted.)

Parameter	From (Input)	To (Output)	$V_{CCB} = 1.2V$	$V_{CCB} = 1.5V \pm 0.1V$		$V_{CCB} = 1.8V \pm 0.15V$		$V_{CCB} = 2.5V \pm 0.2V$		$V_{CCB} = 3.3V \pm 0.3V$		Units
			Typ	Min.	Max.	Min.	Max.	Min.	Max.	Min.	Max.	
$t_{PD}$	A	B	8	1.0	6.0	0.5	5.5	0.5	5.0	0.5	4.5	ns
	B	A	6	1.0	6.0	0.5	5.5	0.5	5.0	0.5	4.5	
$t_{SK(a)}^{(1)}$					0.25		0.25		0.25		0.25	
$t_{SK(b)}^{(1)}$					0.2		0.2		0.2		0.2	
$f_{MAX}$ 10pF load SEL='HIGH'	B	A	15	18		25		35		37		MHz
	A	B	20	20		25		25		27		

### Timing Characteristics for $V_{CCA} = 2.5V \pm 0.2V$

(Over recommended free-air temperature range, unless otherwise noted.)

Parameter	From (Input)	To (Output)	$V_{CCB} = 1.2V$	$V_{CCB} = 1.5V \pm 0.1V$		$V_{CCB} = 1.8V \pm 0.15V$		$V_{CCB} = 2.5V \pm 0.2V$		$V_{CCB} = 3.3V \pm 0.3V$		Units
			Typ	Min.	Max.	Min.	Max.	Min.	Max.	Min.	Max.	
$t_{PD}$	A	B	8	1.0	5.5	0.5	5.0	0.5	4.5	0.5	4.0	ns
	B	A	6	1.0	5.5	0.5	5.0	0.5	4.5	0.5	4.0	
$t_{SK(a)}^{(1)}$					0.25		0.25		0.25		0.25	
$t_{SK(b)}^{(1)}$					0.2		0.2		0.2		0.2	
$f_{max}$ 10pF load SEL='HIGH'	B	A	15	18		25		40		50		MHz
	A	B	23	25		35		40		45		

**Note:**

- This is the skew between any two outputs of the same package, and switching in the same direction. For  $t_{SK(a)}$ , Output 1 and Output 2 are any two outputs. For  $t_{SK(b)}$ , Output 1 and Output 2 are in the same bank. These parameters are warranted but not production tested.

**Timing Characteristics for  $V_{CCA} = 3.3V \pm 0.3V$** 

(Over recommended free-air temperature range, unless otherwise noted.)

Parameter	From (Input)	To (Output)	$V_{CCB} = 1.2V$	$V_{CCB} = 1.5V \pm 0.1V$		$V_{CCB} = 1.8V \pm 0.15V$		$V_{CCB} = 2.5V \pm 0.2V$		$V_{CCB} = 3.3V \pm 0.3V$		Units
			Typ	Min.	Max.	Min.	Max.	Min.	Max.	Min.	Max.	
$t_{pD}$	A	B	7	1.0	5.0	0.5	4.5	0.5	4.0	0.5	3.5	ns
	B	A	6	1.0	5.0	0.05	4.5	0.5	4.0	0.5	3.5	
$t_{SK(a)}^{(1)}$					0.25		0.25		0.25		0.25	
$t_{SK(b)}^{(1)}$					0.2		0.2		0.2		0.2	
$f_{max}$ 10pF load SEL='HIGH'	B	A	16	20		25		45		53		MHz
	A	B	24	25		35		50		55		

**Note:**

- This is the skew between any two outputs of the same package, and switching in the same direction. For  $t_{SK(a)}$ , Output 1 and Output 2 are any two outputs. For  $t_{SK(b)}$ , Output 1 and Output 2 are in the same bank. These parameters are warranted but not production tested.

**Operating Characteristics ( $V_{CCA}$  and  $V_{CCB} = 2.5V$ ,  $T_A = 25^\circ C$ )**

Parameter		Test Conditions	Typ.	Units
$C_{pd}^{(1)}$ ( $V_{CCA}$ )	Power Dissipation Capacitance A to B	Outputs Enabled	15	pF
		Outputs Disabled	2	
	Power Dissipation Capacitance B to A	Outputs Enabled	30	
		Outputs Disabled	10	
$C_{pd}^{(1)}$ ( $V_{CCB}$ )	Power Dissipation Capacitance A to B	Outputs Enabled	30	pF
		Outputs Disabled	10	
	Power Dissipation Capacitance B to A	Outputs Enabled	15	
		Outputs Disabled	2	

**Note:**

- This parameter is specified under test mode conditions.

### Parameter Measurement Information

V <sub>CCA</sub> /V <sub>CCB</sub>	C <sub>L</sub>
1.2V ~ 1.6V	10pF
1.8V ±0.15V	20pF
2.5V ±0.2V	30pF
3.3V ±0.3V	50pF

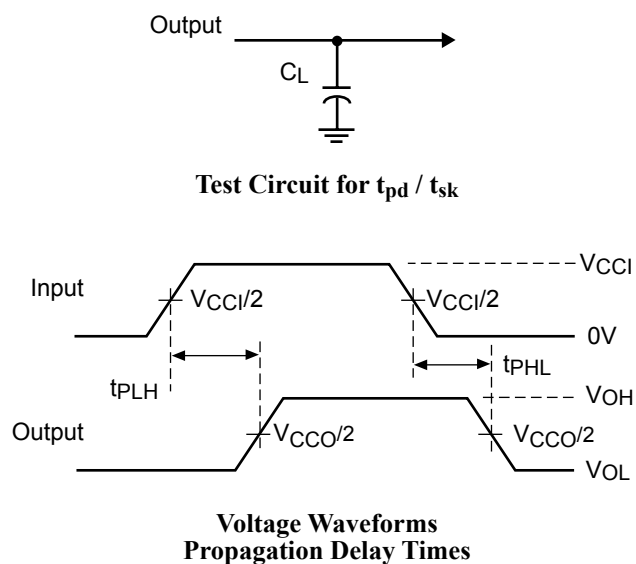

**Figure 1. Load Circuit and Voltage Waveforms**

**Notes:**

- C<sub>L</sub> includes probe and jig capacitance.
- All input pulses are supplied by generators having the following characteristics: PRR ≤ 10Mz, Z<sub>O</sub> = 50Ω, t<sub>r</sub> ≤ 2.5ns, t<sub>f</sub> ≤ 2.5ns.
- The outputs are measured one at a time with one transition per measurement.
- V<sub>CCI</sub> defines the input port (V<sub>CCA</sub> or V<sub>CCB</sub>).
- V<sub>CCO</sub> defines the output port (V<sub>CCA</sub> or V<sub>CCB</sub>).



**Packaging Mechanical: 45-lead VFBGA**

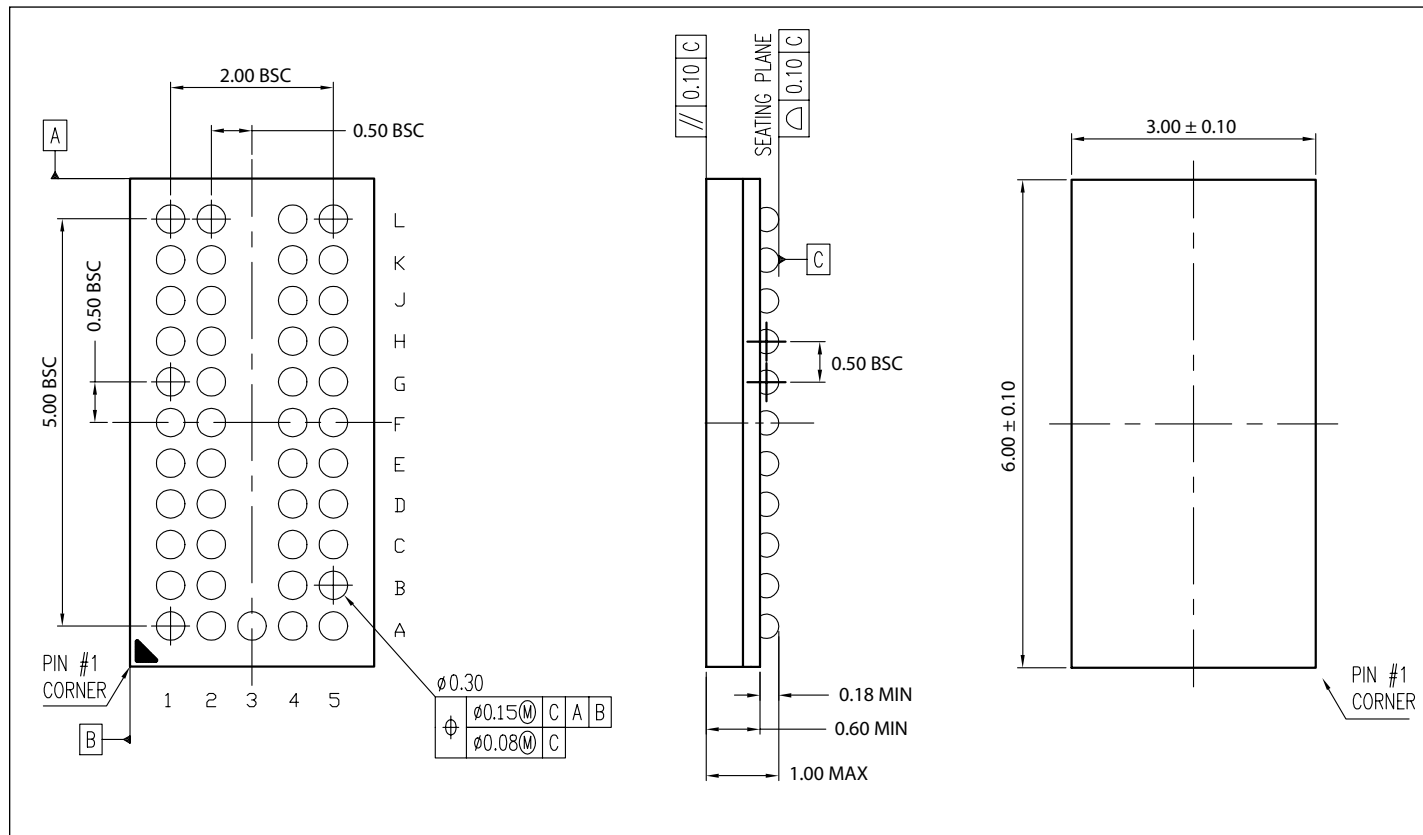

**Ordering Information**

Ordering Code	Packaging Code	Package Description
PI4ULS3V16MNLE	NL	Pb-free & Green, 45-ball VFBGA

**Notes:**

- Thermal characteristics can be found on the company web site at [www.pericom.com/packaging/](http://www.pericom.com/packaging/)
- E= Pb-free and Green
- X suffix = Tape/Reel