

Tous droits strictement réservés. Reproduction ou communication à des fins
 interdite sans permission écrite du propriétaire.
 Property of FCI. Copyright FCI.

A
FCI

All rights strictly reserved. Reproduction or communication to any
 form without written permission is prohibited.
 Property of FCI. Copyright FCI.

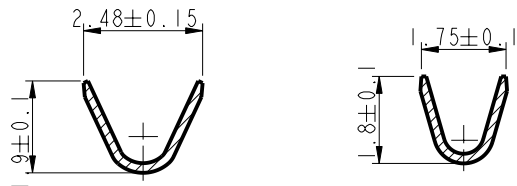
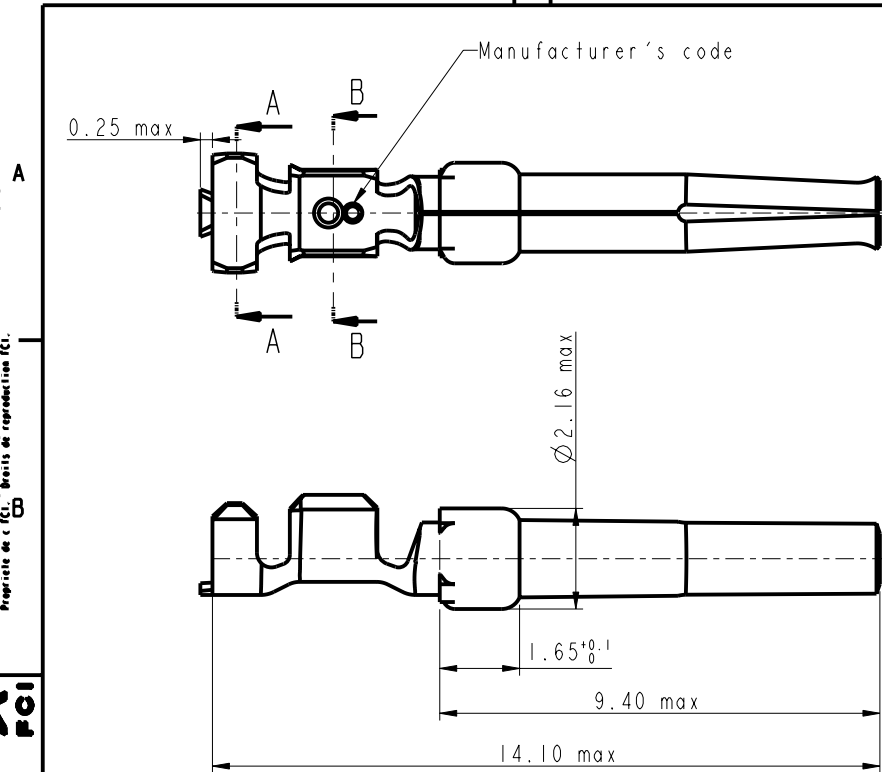

SECTION A-A

SECTION B-B

NOTES:

- 1-Material:phosphor bronze,thickness 0.20
- 2-Finish on contact area:see table
finish on termination:bright tin lead over nickel
- 3-Wire range:20 to 24 AWG
- 4-Max outer dia of wire insulator:1.73 mm
- 5-Current carrying capacity per contact:
5.Amps max when crimped to #20 AWG
5 Amps max when crimped to #22 AWG
3 Amps max when crimped to #24 AWG
- 6-After 5 insertions into connector,
contact retention must be 5 pounds axial load min
- 7-When contact is crimped to 20 AWG,the insulation
support crimped height must be 1.78 mm max to ensure
a proper insertion into housing
- 6-Packaging:Box of 500 contacts

NOTE:ROHS INFORMATIONS

The LF products meet European union directives and other country regulations as described in GS-22-008
 Terminations plating spec:2µm Nickel min + 2µm Sn min
 Packaging spec: see GS-14-930

CORE RANGE	.
8656353064LF	Flash Au
8656353064	Flash Au
PART NUMBER	Plating

lfr	ecn no	dr	date
D	LS05-006	MPE	14/06/05
-	-	-	-
-	-	-	-
-	-	-	-
-	-	-	-
-	-	-	-
-	-	-	-
-	-	-	-
-	-	-	-

A FCI	www.fciconnect.com		surface <input checked="" type="checkbox"/>	tolerance <input checked="" type="checkbox"/>	projection <input checked="" type="checkbox"/>	Scale 10:1
	Dr	C JARRY	28/01/97	Product family	size A3	
Eng				Spec ref		
Chr				Material	SEE NOTES	ECN
Appr						
title CRIMP SOCKET				dwg no C01-8656-0512		Rev. D
#WIRE 20-24 in box 500 cts				catalog no		CUSTOMER COPY sheet 1 of 1