

UTC 2SD718 NPN EPITAXIAL SILICON TRANSISTOR

HIGH POWER AMPLIFIER APPLICATION

FEATURES

- *Recommended for 45~50W Audio Frequency Amplifier Output Stage.
- *Complementary to 2SB688.

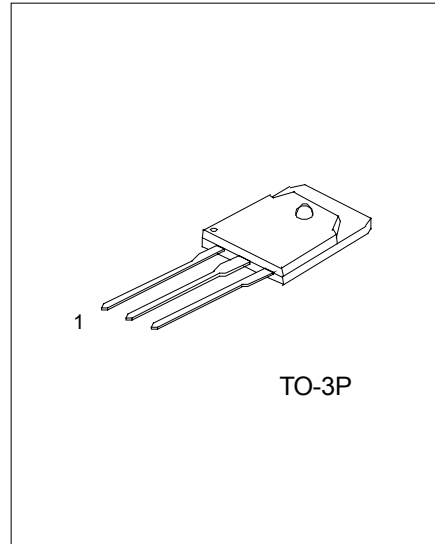

1: BASE 2:COLLECTOR 3: EMITTER

ABSOLUTE MAXIMUM RATINGS (Ta=25°C)

PARAMETER	SYMBOL	RATINGS	UNIT
Collector-Base Voltage	V _{CB0}	120	V
Collector-Emitter Voltage	V _{CEO}	120	V
Emitter-Base Voltage	V _{EB0}	5	V
Collector Current	I _c	10	A
Base Current	I _b	1	A
Collector Power Dissipation (T _c =25°C)	P _c	80	W
Junction Temperature	T _j	150	°C
Storage Temperature Range	T _{stg}	-55 ~150	°C

ELECTRICAL CHARACTERISTICS (Ta=25°C, unless otherwise specified)

PARAMETER	SYMBOL	TEST CONDITION	MIN	TYP	MAX	UNIT
Collector-Emitter Breakdown Voltage	V _{(BR)CEO}	I _c =50mA, I _b =0	120			V
Collector Cut-off Current	I _{CB0}	V _{CB} =120V, I _E =0			10	μA
Emitter Cut-off Current	I _{EB0}	V _{EB} =5V, I _c =0			10	μA
DC Current Gain	h _{FE}	V _{CE} =5V, I _c =1A	55		160	
Collector-Emitter Saturation Voltage	V _{CE(sat)}	I _c =6A, I _b =0.6A			2.0	V
Base-Emitter Voltage	V _{BE}	V _{CE} =5V, I _c =5A			1.5	V
Transition Frequency	f _r	V _{CE} =5V, I _c =1A		12		MHz
Collector Output Capacitance	C _{ob}	V _{CB} =10V, I _E =0, f=1MHz		170		pF

CLASSIFICATION OF h_{FE}

RANK	R	O
RANGE	55-110	80-160

UTC 2SD718 NPN EPITAXIAL SILICON TRANSISTOR

ELECTRICAL CHARACTERISTICS CURVES

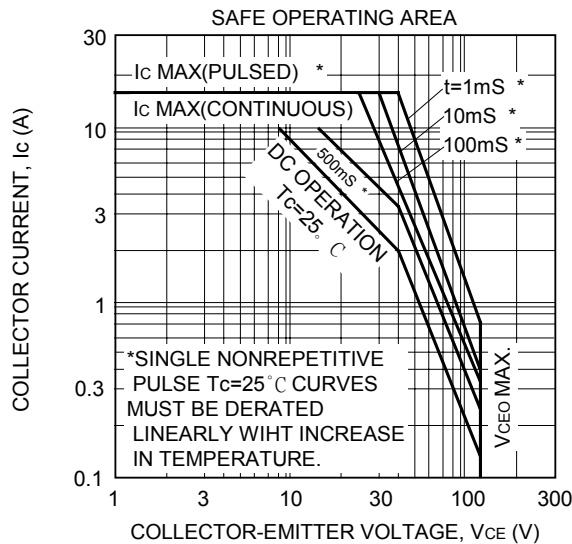
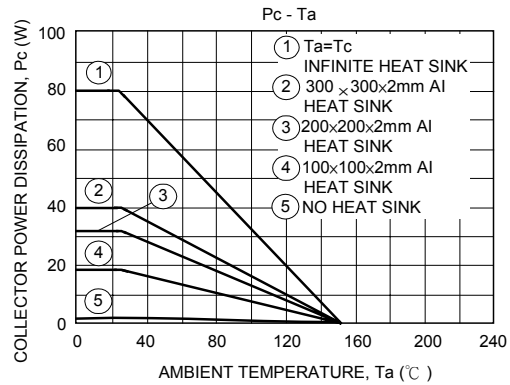
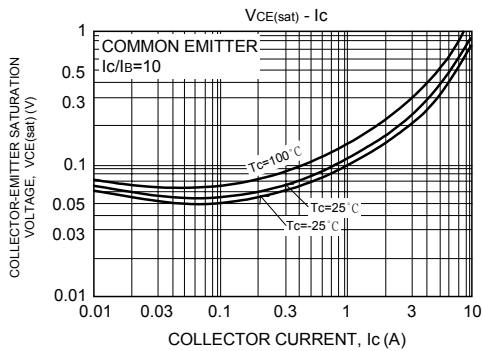
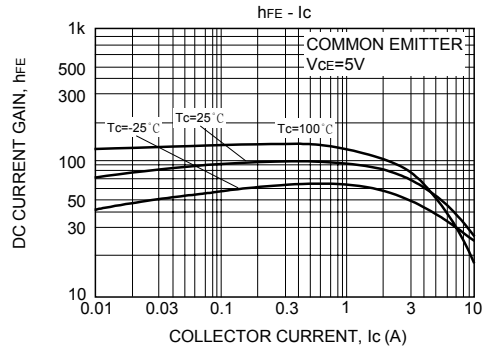
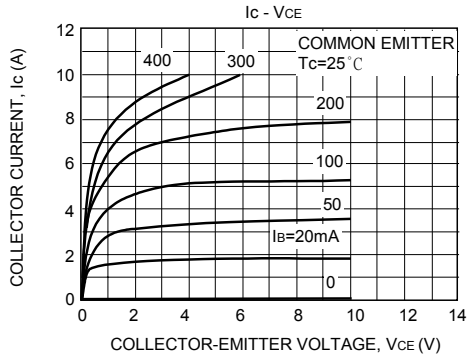

UTC 2SD718 NPN EPITAXIAL SILICON TRANSISTOR

UTC assumes no responsibility for equipment failures that result from using products at values that exceed, even momentarily, rated values (such as maximum ratings, operating condition ranges, or other parameters) listed in products specifications of any and all UTC products described or contained herein. UTC products are not designed for use in life support appliances, devices or systems where malfunction of these products can be reasonably expected to result in personal injury. Reproduction in whole or in part is prohibited without the prior written consent of the copyright owner. The information presented in this document does not form part of any quotation or contract, is believed to be accurate and reliable and may be changed without notice.