

- Designed to comply with the requirements of UL1950 and EN60950 to provide a supplementary insulation barrier with a working voltage of 250V
- UL File Number E169987
- BABT certificate number NC/011393
- CB test certificate NEMKO 12571
- Minimum interwinding breakdown voltage of 1500 Vrms
- Operating and storage temperature range: -40° to +85° C
- Meets IEC 695, 2-2 flammability requirements
- PWB Process Capability: standard printed wiring board assembly techniques, total-immersion cleaning
- Reliability testing: shock, vibration, temperature cycling, temperature - humidity - bias

**ELECTRICAL SPECIFICATIONS AT 25° C**

Part Number	Turns Ratio ±2%	Inductance <sup>1</sup> µH ±5%	Leakage Inductance µH max	DCR Ω max		Longitudinal Balance <sup>2</sup> dB min	Insertion Loss <sup>2</sup> dB max	Frequency Response <sup>2</sup> dB max	Harmonic Distortion <sup>2</sup> dB max
	Chip : Line	Line Side	Line Side	Chip Side	Line Side	100 kHz	300 kHz	100 kHz - 1.1MHz	100 kHz 15 Vpp
S560-6600-CE	1 : 1.91	92.5	2	0.27	0.53	60	0.25	±0.5	-80

All measurements are made with pins 2 and 3 connected and pins 6 and 7 connected

1. Inductance measured at 100 kHz, 0.1 Vac
2. Measurements made with 100Ω source impedance

**SCHEMATIC**

**S560-6600-CE**

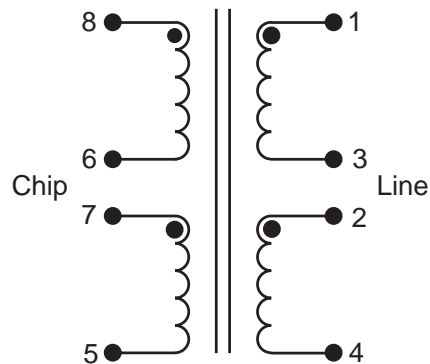

TM01352

### MECHANICAL

S560-6600-CE

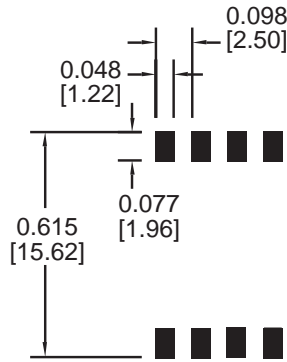
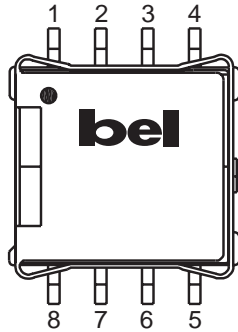

Suggested PCB Pad Layout

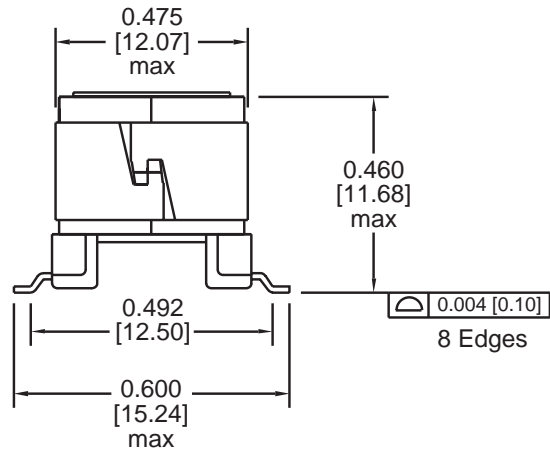
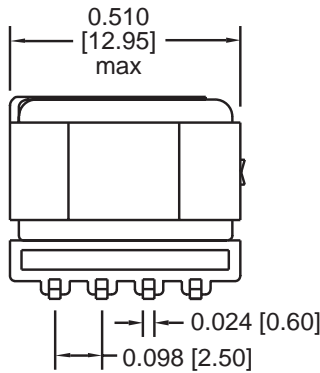

Dimensions are in inches [millimeters].  
Standard dimension tolerance is  $\pm 0.005$  [0.13] unless otherwise noted.

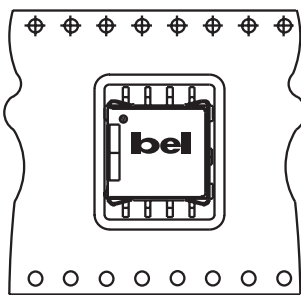

➔ User Feed Direction

Orientation of Component Inside Pocket

### Tape and Reel Packaging

32 mm wide by 24 mm pitch; 13 inch OD, 4 inch ID  
200 components per reel, maximum  
Meets ANSI/EIA 481-2 Carrier Tape Standards

©2001 Bel Fuse Inc. Specifications subject to change without notice. 08.01

### CORPORATE

**Bel Fuse Inc.**  
206 Van Vorst Street  
Jersey City, NJ 07302  
Tel 201-432-0463  
Fax 201-432-9542  
www.belfuse.com

### FAR EAST

**Bel Fuse Ltd.**  
8F / 8 Luk Hop Street  
San Po Kong  
Kowloon, Hong Kong  
Tel 852-2328-5515  
Fax 852-2352-3706  
www.belfuse.com

### EUROPE

**Bel Fuse Europe Ltd.**  
Preston Technology Management Centre  
Marsh Lane, Suite G7, Preston  
Lancashire, PR1 8UD, U.K.  
Tel 44-1772-556601  
Fax 44-1772-888366  
www.belfuse.com