

TELEPHONE SPEECH CIRCUITS

- 2/4 WIRE INTERFACE
- OPERATES DOWN TO 4 mA
- 3.5 V_{pp} DYNAMIC IN SENDING AT 25 mA

DESCRIPTION

The LS285 is monolithic integrated circuits for replacement of the hybrid circuit (2-4 wire interface) in conventional telephones interfacing the two transducers to the line and providing a controlled amount of sidetone.

The same type of transducer can be used for both transmitter and receiver, usually a 350 Ω dynamic type.

By sensing the line current, LS285 adjusts the gain in both directions to compensate for line attenuation.

Output impedance can be matched to the line, independent of transducer impedance.

The LS285 is packaged in a 14 lead dual in-line plastic package.

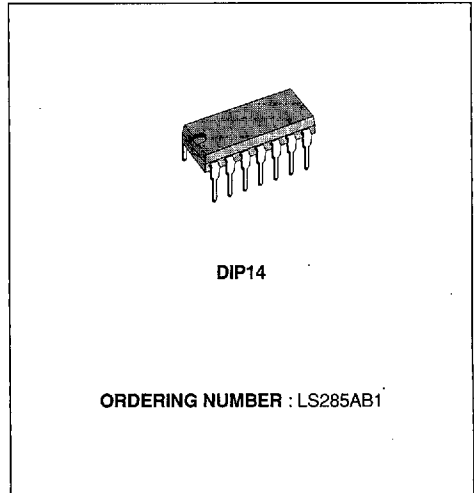

PIN CONNECTION (top view)

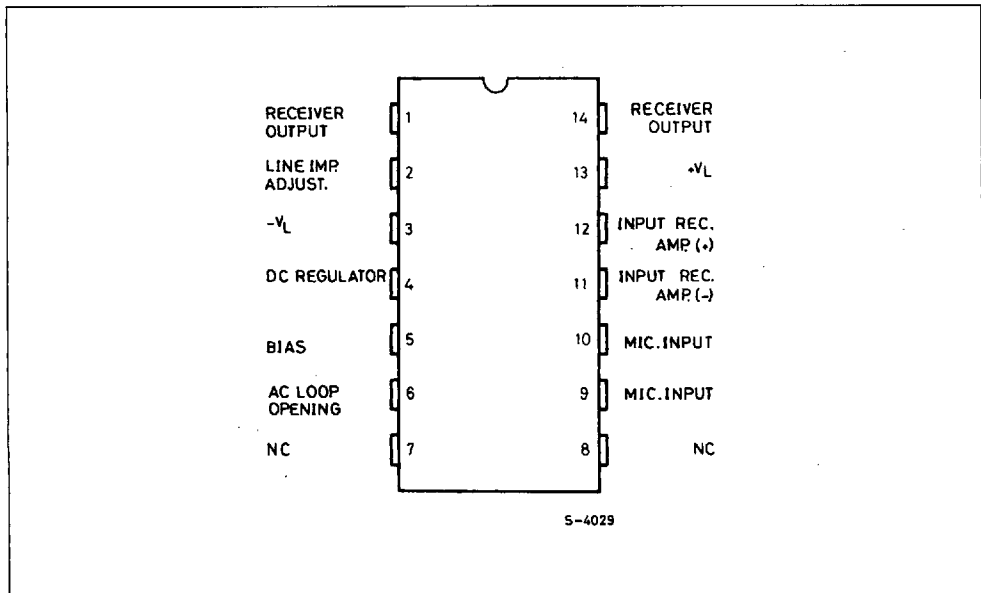

BLOCK DIAGRAM

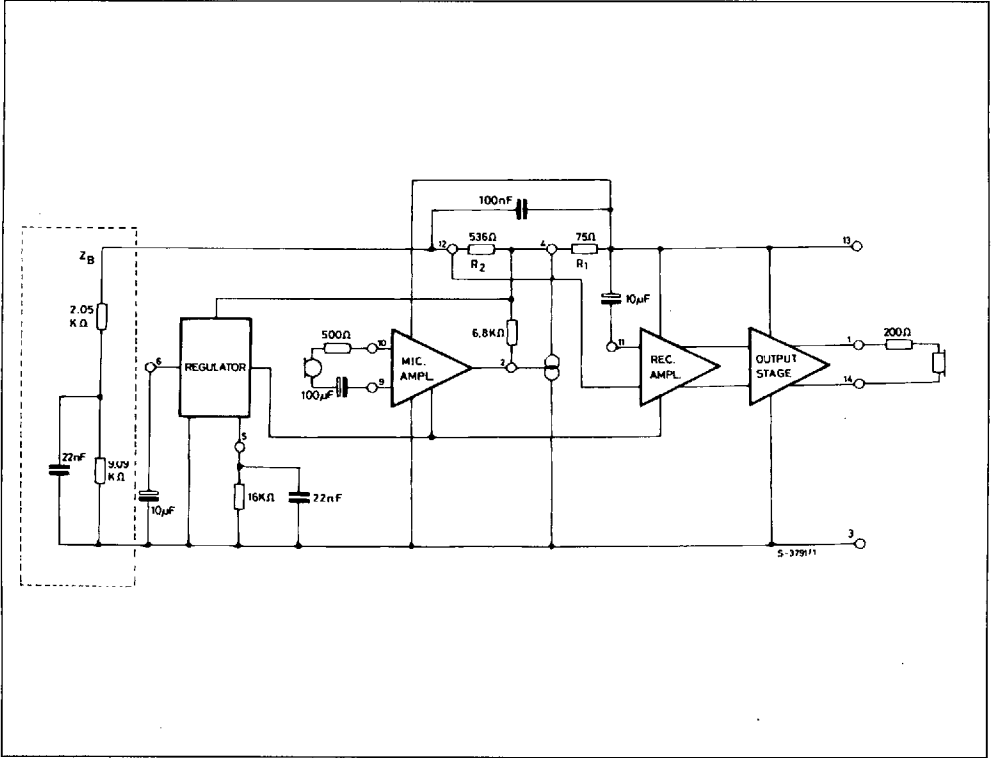

ABSOLUTE MAXIMUM RATINGS

Symbol	Parameter	Value	Unit
V_L	Line Voltage (3 ms pulse duration)	22	V
I_L	Forward Current	120	mA
I_L	Reverse Current	- 150	mA
P_{tot}	Total Power Dissipation at $T_{amb} = 70\text{ }^\circ\text{C}$	1	W
T_{stg}	Storage and Junction Temperature	- 55 to 150	$^\circ\text{C}$
T_{op}	Operating Temperature	- 40 to 70	$^\circ\text{C}$

THERMAL DATA

Symbol	Parameter	Value	Unit
$R_{th\ j-amb}$	Thermal Resistance Junction-ambient	Max<0>	$^\circ\text{C/W}$

DESCRIPTION

The LS285 is based on a bridge configuration. They contain a regulator block, a sending amplifier and a receiver amplifier.

The regulator monitors the line current and adjusts the amplifier gain to compensate for the line length. It provides DC characteristics in line with CEPT standards.

The transmit/receiver amplifiers are connected to the line via an external bridge to provide sidetone attenuation.

The line current compensation ensures that when the subscriber is talking, the signal delivered to the line is increased in according to the line length. When he is hearing, the signal level on the receiver capsule is constant.

The amplifiers can also be matched to different transducers simply by varying external components. Gain variation over the operating temperature range is less than ± 1 dB.

The impedance to the line can be adjusted ; without any change in circuit parameters ; by changing an external resistor (6.8 K Ω at pin 2).

BASIC CIRCUIT CONFIGURATION.

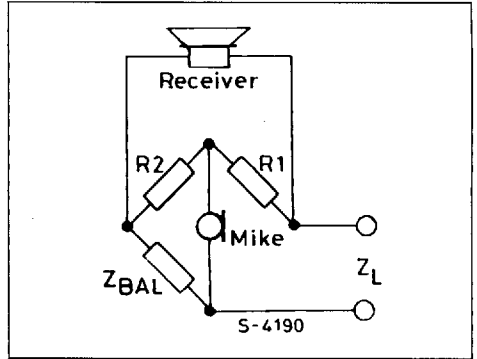

Figure 1 : Test Circuit.

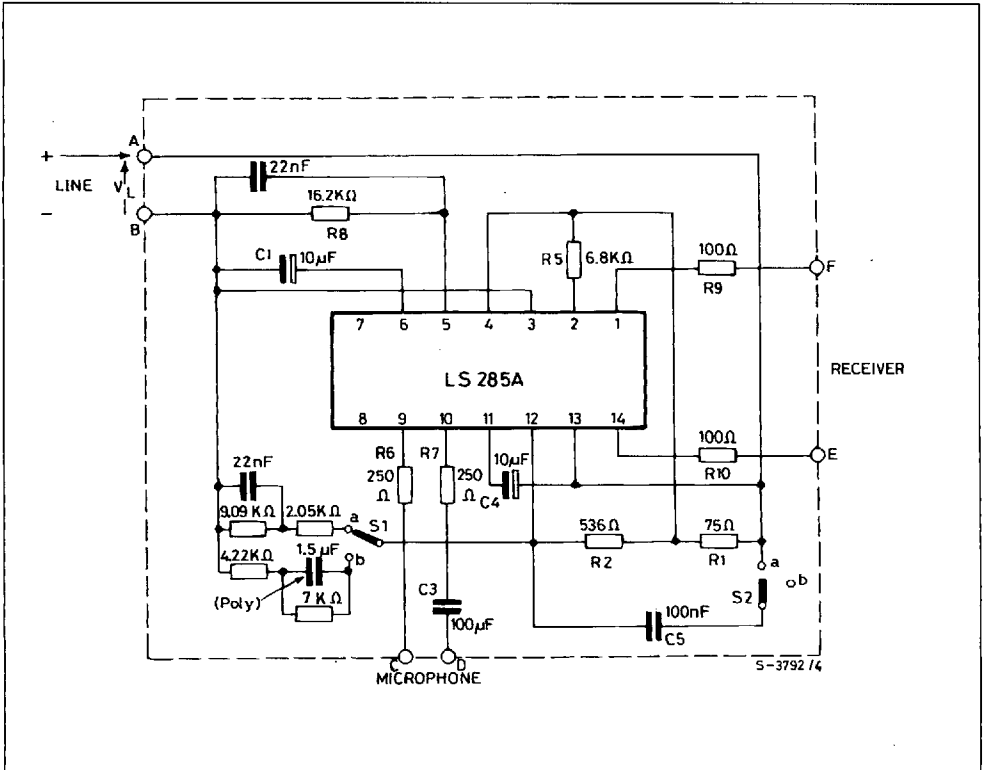

Figure 2 : Sending Gain.

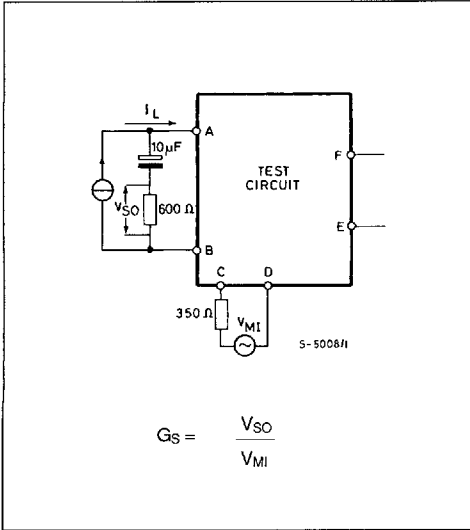

Figure 3 : Receiving Gain.

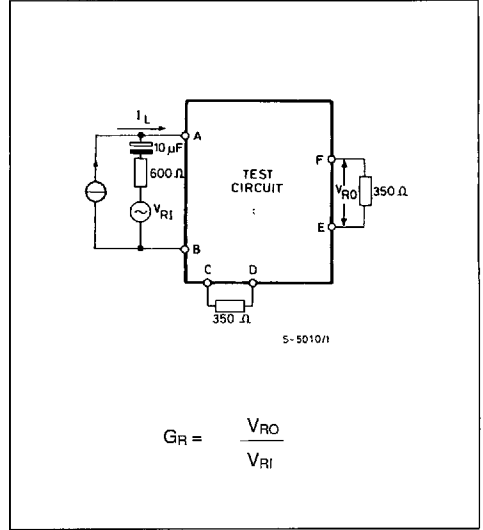

Figure 4 : Sidetone.

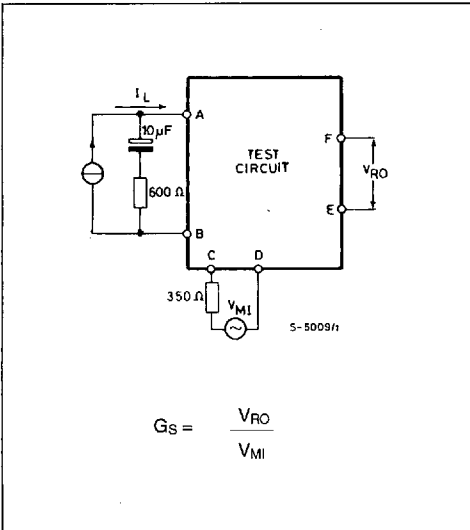
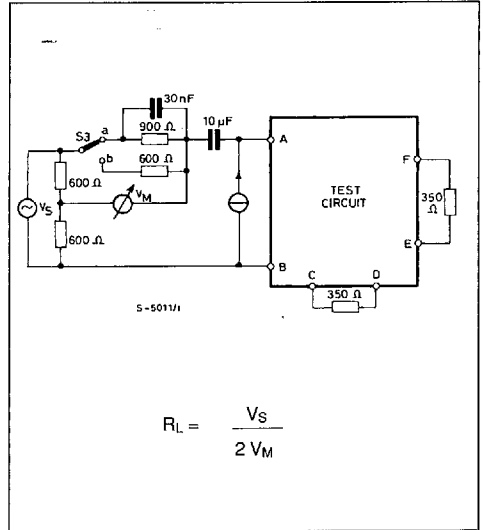

Figure 5 : Return Loss.



ELECTRICAL CHARACTERISTIC(refer to the test circuit, $T_{amb} = 25^{\circ}\text{C}$, $f = 300\text{Hz}$ to 3400Hz , S1, S2 in "a" unless otherwise specified)

Symbol	Parameter	Test Conditions	Min.	Typ.	Max.	Unit	Fig.
V_L	Line Voltage	$-15^{\circ}\text{C} < T_{amb} < +45^{\circ}\text{C}$ $I_L = 80\text{mA}$ $I_L = 20\text{mA}$ $I_L = 10\text{mA}$	9.5 4.8 3.6		11.5 5.8 1.6	V	1
G_s	Sending Gain	$f = 1\text{kHz}$ $I_L = 15\text{mA}$, $V_{MI} = 1.0V_{RMS}$ $I_L = 30\text{mA}$, $V_{MI} = 2.5V_{RMS}$ $I_L = 60\text{mA}$, $V_{MI} = 3.7V_{RMS}$ $I_L = 80\text{mA}$, $V_{MI} = 4.5V_{RMS}$	48.5 47.9 42.7 42.0		52.5 51.5 46.1 45.3	dB	2
G_s	Sending Gain Variation versus Temperature	$-15^{\circ}\text{C} < T_{amb} < +45^{\circ}\text{C}$		0.8		dB	2
	Sending Gain Flatness	$I_L = 10$ to 80mA $f_{ref} = 1\text{kHz}$, S1, S2 in (b)	-0.5		+0.5	dB	2
	Sending Distortion	$I_L = 10$ to 15mA , $V_{SO} < 0 > = < 0 > 0.7 V_p$ $I_L = 16$ to 24mA , $V_{SO} < 0 > = < 0 > 1.3 V_p$ $I_L = 25$ to 80mA , $V_{SO} < 0 > = < 0 > 1.75 V_p$			2 2 10	% % %	2 2 2
	Sending Noise	$V_{MI} = 0\text{V}$, $I_L = 60\text{mA}$		-73		dBmp	2
	Microphone Amplifier Impedance (pin 9-10)			95		Ω	1
	Max Sending Output (*)	$I_L = 10$ to 80mA , $V_{MI} = 1\text{V}$			3	V_p	2
G_R	Receiving Gain	$f = 1\text{kHz}$ $I_L = 15\text{mA}$, $V_{RI} = 0.8V_{RMS}$ $I_L = 30\text{mA}$, $V_{RI} = 1.0V_{RMS}$ $I_L = 60\text{mA}$, $V_{RI} = 1.8V_{RMS}$ $I_L = 80\text{mA}$, $V_{RI} = 10V_{RMS}$	-13.3 -13.5 -18 -19		-9.3 -10.5 -14.9 -16	dB	3
ΔG_R	Receiving Gain Variation versus Temperature	$-15^{\circ}\text{C} < T_{amb} < +45^{\circ}\text{C}$		0.25		dB	3
	Receiving Gain Flatness	$f_{ref} = 1\text{kHz}$ $I_L = 10$ to 80mA , S1, S2 in (b)	-0.5		+0.5	dB	3
	Receiving Distortion	$I_L = 10$ to 15mA , $V_{RO} = 300mV_p$ $I_L = 15$ to 80mA , $V_{RO} = 500mV_a$			2 2	% %	3 3
	Receiving Amplifier Output Impedance (pin 1-14)			110		Ω	1
	Receiving Noise	$V_{RI} = 0\text{V}$, $I_L = 60\text{mA}$, psophometric		80		μV	3
	Max receiving Output Current	$I_L = 80\text{mA}$, $V_{RI} = 10\text{V}$			3.6	mAp	3
	Sidetone	$f = 1\text{kHz}$ $I_L = 20\text{mA}$ $I_L = 80\text{mA}$		7 0		dB dB	4 4
	Return Loss	S3 in (a) S3 in (b)		14 14		dB dB	5 5

(*) This output is limited to allow for input overvoltages.

Figure 6 : Typical Application Circuit.

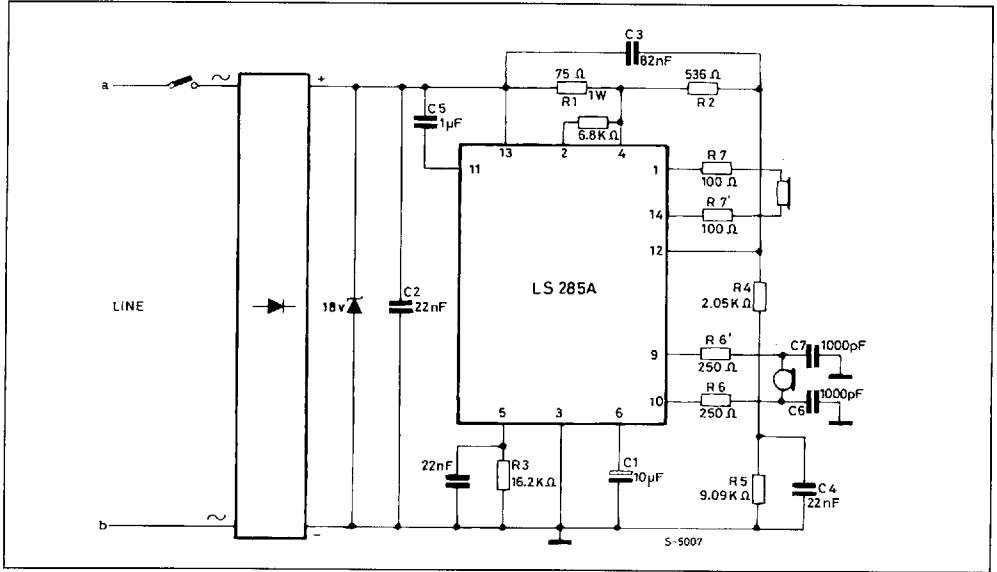

APPLICATION INFORMATION

The following table shows the recommended values for the typical application circuit of fig. 6. Different values can be used and notes are added in order to help designer.

Component	Recommended Value	Purpose	Note
R1	75Ω	Bridge Resistors	The ratio R2/R1 fixes the amount of the signal delivered to the line. (see fig. 7)
R2	536Ω		
R3	16.2kΩ	Bias Resistor	Changing R3 value it is possible to shift the gain characteristics. The value can be chosen from 15kΩ to 20<0>kΩ. The recommended value assures the maximum swing (see fig. 9).
R4	2.05kΩ	Balance Network	In order to optimize the sidetone it is possible to change R4 and R5 values. In any case : $\frac{Z_B}{Z_L} = \frac{R_2}{R_1}$ where $Z_B = R_4 + R_5/C_4$.
R 5	9.09kΩ		
R6 and R6'	250Ω	Microphone Impedance Matching	R6 and R6' must be equal ; 250 Ω is a typical value for dynamic capsules. Furthermore, they determine a sending gain variation according to : $\Delta G_S = 20 \log \frac{R_x}{850\Omega}$ where $R_x = R_6 + R_6' + R_{mike}$. The trend of ΔG_S as a function of R_x value is shown in fig. 8.
R7 and R7'	100Ω	Receive Impedance Matching	R7 and R7' must be equal ; 100Ω is a typical value for dynamic capsules.
C1	10 μF	AC Loop Opening	Ensures a high regulator impedance for AC signals ($\approx 20k\Omega$). This capacitor should not be higher than 10 μF in order to have a short response time of the system.
C2	22nF	Matching to a Capacitive Line	C2 changes with the characteristics of the transmission line.
C3	82nF	High Frequency Roll-off	C3 determines the high frequency response of the circuit. it also acts as RF bypass.
C4	22nF	Balance Network	See Note for R4 and R5.
C5	1 μF	DC decoupling for Receiving Input	
C6 and C7	1000pF	RF Bypass	
C8	22nF	Filtex Capacitor	

Figure 7 : Receiving Gain Variation vs. R1 Value
(with fixed R1/R2 ratio).

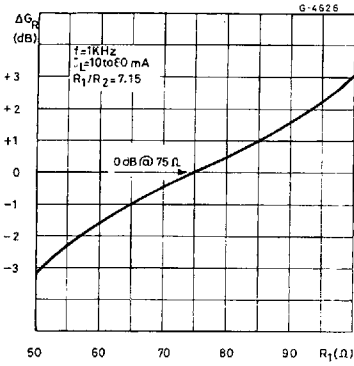

Figure 8 : Sending Gain Variation vs. Rx Value
(see note for R6 and R6').

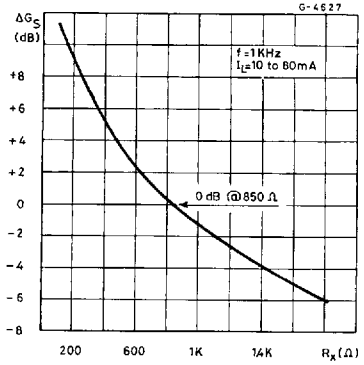

Figure 9 : Sending and receiving Gain Variation vs. Line Current.

