

**4302F-5V, 4302F-12V Series Integrated Resistor 5 Volts 12 Volts T-1 (3mm)**

**DESCRIPTION AND FEATURES**

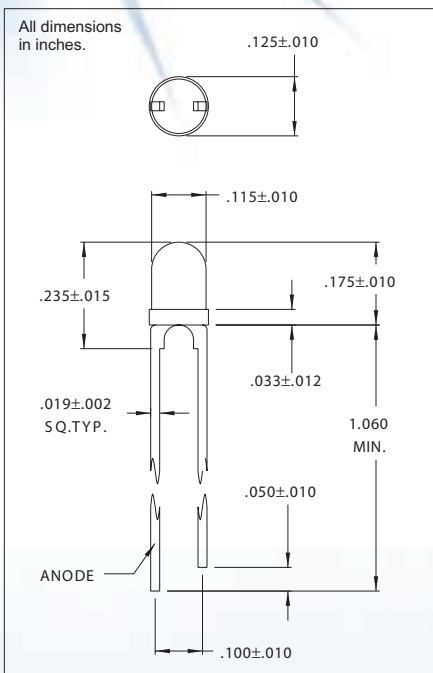

- High brightness output
- Integral current limiting resistor
- TTL compatible requires no external current limiter with 5 volt or 12 volt supply.
- Wide viewing angle - 60°.

**ELECTRO-OPTICAL CHARACTERISTICS AND RATINGS**

PART NUMBER	4302F1-5V	4302F3-5V	4302F5-5V	4302F1-12V	4302F3-12V	4302F5-12V
Output Color	Red	Amber	Green	Red	Amber	Green
Diffusion	Diffused	Diffused	Diffused	Diffused	Diffused	Diffused
Package Color	Red	Amber	Green	Red	Amber	Green
Rated Current (mA)	10	10	10	13	13	13
Forward Voltage Typ. (V)	5	5	5	12	12	12
Forward Voltage Max. (V)	7.5	7.5	7.5	15	15	15
Luminous Intensity Min. (mcd)	2.0	2.0	2.0	2.0	2.0	2.0
Luminous Intensity Typ. (mcd)	8.0	8.0	8.0	8.0	8.0	8.0
Continuous Forward Current Max. (mA)	20	15	15	20	20	20
Peak Wavelength (nm)	635	583	565	635	583	565
Viewing Angle 2θ 1/2 (degrees)	60	60	60	60	60	60
Reverse Breakdown Voltage Min. (V)	5	5	5	5	5	5