

ELECTRICAL SPECIFICATIONS:

- | | | | |
|-----|---------------------------|--|--|
| 1.0 | URNS RATIO: | $(P6-P5-P4) : (J6-J3)$
$(P3-P2-P1) : (J2-J1)$ | : 1CT : 1CT ± 3%
: 1CT : 1CT ± 3% |
| 2.0 | INDUCTANCE: | $(P6-P4)$
$(P3-P1)$ | : 350uH MIN. @ 0.1V, 100KHz, 8mA DC Bias
: 350uH MIN. @ 0.1V, 100KHz, 8mA DC Bias |
| 3.0 | LEAKAGE INDUCTANCE: | P6-P4 (WITH J6 AND J3 SHORT)
P3-P1 (WITH J2 AND J1 SHORT) | : 0.3 MAX. @ 1MHz
: 0.3 MAX. @ 1MHz |
| 4.0 | INTERWINDING CAPACITANCE: | $(P6,P5,P4)$ TO $(J6,J3)$
$(P3,P2,P1)$ TO $(J2,J1)$ | : 30pf MAX @ 1MHz
: 30pf MAX. @ 1MHZ |
| 5.0 | DC RESISTANCE: | $(J6-J3)=(J2-J1)$ | 1.2 ohms Max. |

NOTES

1.0 PINS WITHOUT ELECTRICAL CONNECTION ARE OMITTED.

Bel Stewart Connector
11118 Susquehanna Trail, South
Glen Rock, Pa 17327-9199
717.234.7512

MagJack[®]

<http://www.stewartconnector.com>

SHEET
1 OF 4

DRAWING NO.
CH0042-SL2

REV.
13

RECEIVE

- 6.0 RETURN LOSS: 1MHz TO 30MHz : 18dB MIN.
60MHz TO 80MHz : 12dB MIN.
NOTE: 100 OHMS CONNECTED TO (J2-J1) OR (J6-J3).
- 7.0 DIELECTRIC WITHSTAND: (J1, J2) TO (P1, P3) : 1500 VAC
(J3, J6) TO (P4,P6) : 1500 VAC
- 8.0 INSERTION LOSS: RS=RL=100 ohms : 1.1 dB TYP
100KHz TO 100MHz
- 9.0 RISE TIME: RS=100 OHMS AND RL = 100 OHMS : 3.0 nS MAX
OUTPUT VOLTAGE = 1 V peak : 3.0 nS MAX
PULSE WIDTH= 112nS
- 10.0 CROSS TALK: 1MHz TO 100MHz : 40 dB TYP
- 11.0 COMMON TO COMMON MODE ATTENUATION: 30MHz TO 100MHz : 35dB TYP

Bel Stewart Connector
11118 Susquehanna Trail, South
Glen Rock, Pa 17327-9199
717.234.7512

MagJack[®]

<http://www.stewartconnector.com>

SHEET
2 OF 4

DRAWING NO.
CH0042-SL2

REV.
13

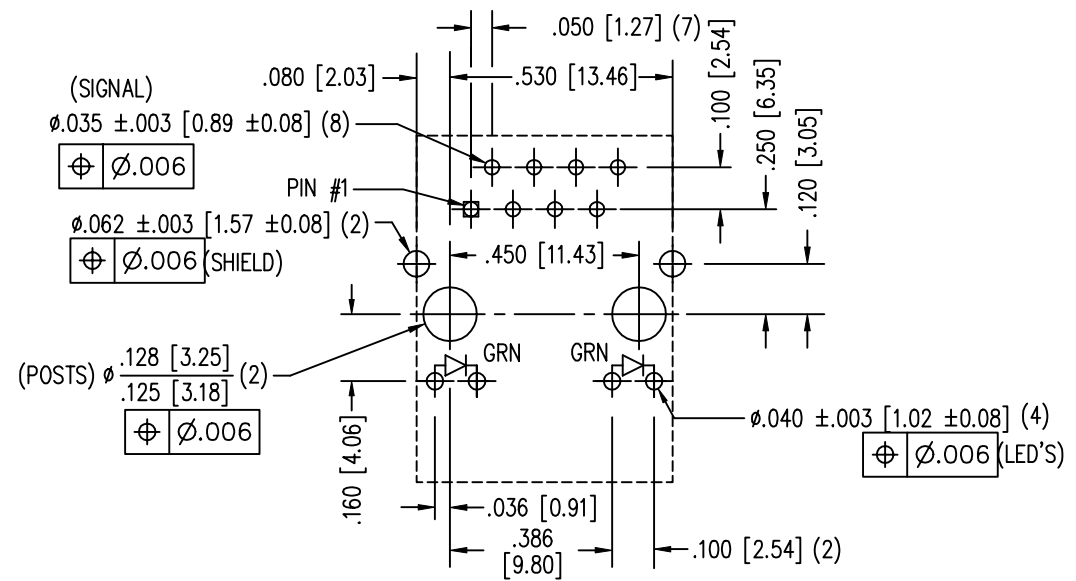
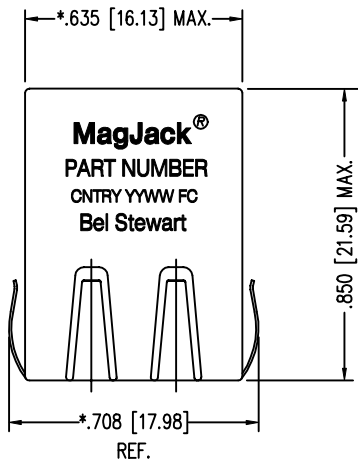

P.C.B. RECOMMENDED HOLE LAYOUT
SEEN FROM COMPONENT SIDE

ALL CENTERLINE DIMENSIONS ARE BASIC.

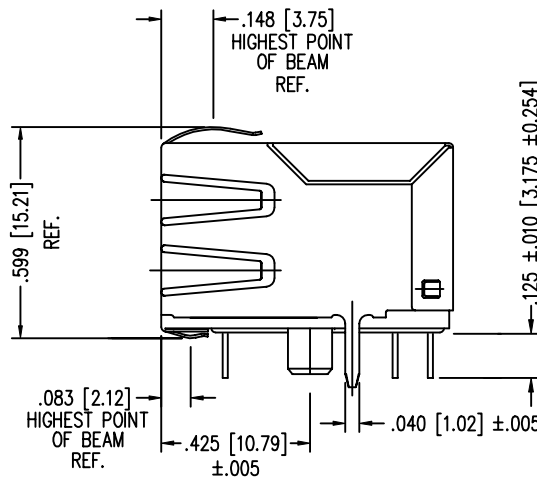
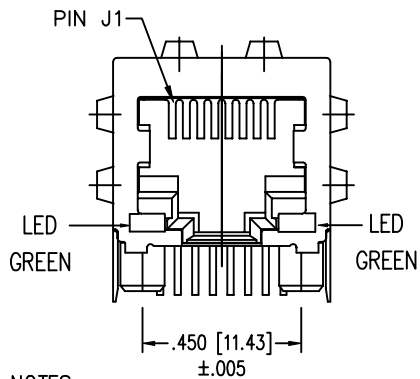

NOTES:

- CONNECTOR MATERIALS:
HOUSING: THERMOPLASTIC UL94 V-0
CONTACT/SHIELD: COPPER ALLOY
SHIELD PLATING: NICKEL OR TIN
CONTACT PLATING: SELECTIVE GOLD,
50 MICRO-INCHES MIN. IN CONTACT AREA.
- PIN NOT ELECTRICALLY CONNECTED MAYBE OMITTED.
SEE ELECTRICAL DRAWING FOR OMITTED PINS.
- TOLERANCES COMPLY WITH F.C.C. DIMENSION REQUIREMENTS.
- WAVE SOLDER COMPATIBLE - PREHEAT 125°C/90SECS.
HIGH TEMPERATURE REFLOW COMPATIBLE - 230°C/90 SEC MAX.

LED SPECIFICATION			
STANDARD LED	WAVELENGTH	* Forward V (MAX)	(TYP)
GREEN	565 nm	2.5 V	2.1 V

*WITH A FORWARD CURRENT OF 20 mA

Bel Stewart Connector
11118 Susquehanna Trail, South
Glen Rock, Pa 17327-9199
717.234.7512

MagJack®

<http://www.stewartconnector.com>

SHEET
3 OF 4

DRAWING NO.
CH0042-SL2

REV.
12

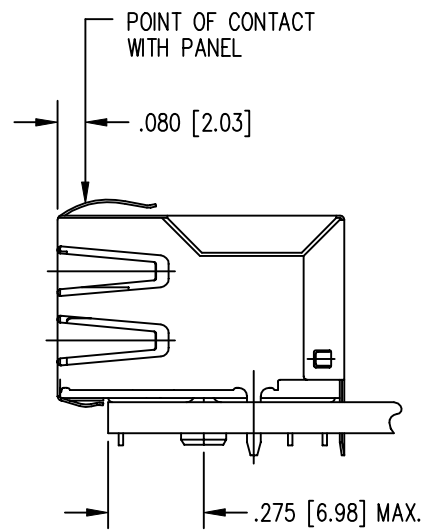
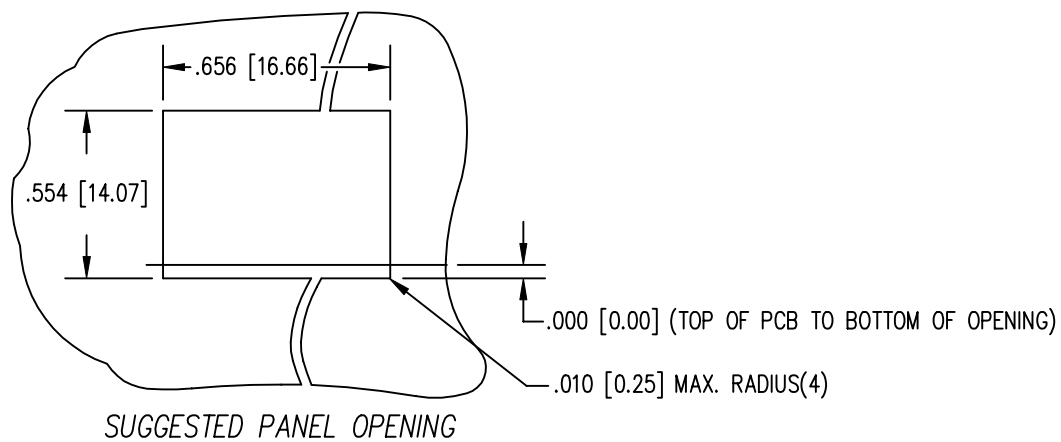

THE SUGGESTED PANEL OPENING IS INTENDED TO GIVE THE USER THE ABILITY TO HAVE REASONABLE JACK / PANEL CLEARANCES YET MAINTAIN RELIABLE GROUNDING CAPABILITY.

Bel Stewart Connector
 11118 Susquehanna Trail, South
 Glen Rock, Pa 17327-9199
 717.234.7512

MagJack[®]

<http://www.stewartconnector.com>

SHEET
4 OF 4

DRAWING NO.
CH0042-SL2

REV.
12