



SANYO Semiconductors

DATA SHEET

LA77000V — Monolithic Linear IC VHF Band RF Modulator (US3, 4ch Compatible)

Overview

The LA77000V is a VHF band RF module that supports US3, 4ch Compatible.

Functions

- RF VCO (AGC).
- RF Mixer.
- RF Buffer.
- Video clamp.
- White clipping.
- Audio FM.
- 4V regulator.
- Reference OSC.

Specifications

Maximum Ratings at Ta = 25°C

Parameter	Symbol	Conditions	Ratings	Unit
Maximum supply rating	V _{CC} max		7.0	V
Allowable power dissipation	Pd max	Ta ≤ 75°C	350*	mW
Operating temperature	T _{opr}		-20 to +75	°C
Storage temperature	T _{stg}		-55 to +150	°C

* Mounted to the glass epoxy resin made board (114.3mm×76.1mm×1.6mm)

Operating Conditions at Ta = 25°C

Parameter	Symbol	Conditions	Ratings	Unit
Recommended operating voltage	V _{CC}		5.0	V
Operating voltage range	V _{CC} op		4.5 to 5.5	V

■ Any and all SANYO Semiconductor products described or contained herein do not have specifications that can handle applications that require extremely high levels of reliability, such as life-support systems, aircraft's control systems, or other applications whose failure can be reasonably expected to result in serious physical and/or material damage. Consult with your SANYO Semiconductor representative nearest you before using any SANYO Semiconductor products described or contained herein in such applications.

■ SANYO Semiconductor assumes no responsibility for equipment failures that result from using products at values that exceed, even momentarily, rated values (such as maximum ratings, operating condition ranges, or other parameters) listed in products specifications of any and all SANYO Semiconductor products described or contained herein.

SANYO Semiconductor Co., Ltd.

TOKYO OFFICE Tokyo Bldg., 1-10, 1 Chome, Ueno, Taito-ku, TOKYO, 110-8534 JAPAN

LA77000V

Electrical Characteristics/Operating Characteristics at Ta = 25°C, V_{CC} = 5.0V, Measured with US3ch unless otherwise specified

Parameter	Symbol	Conditions	Ratings			Unit
			min	typ	max	
Current drain 1	I _{CC1}	No signal, pin 6 high	28	41	53	mA
Current drain 2	I _{CC2}	No signal, pin 6 low	15	22	29	mA
Regulator voltage	V _{reg}	No signal	3.7	3.9	4.1	V
Antenna driver voltage	V _{ant}	Pin 6 high, 220Ω load	3.2	3.5	3.8	V
Negative Resistance (pin7)	-R	Cl≤100	1.2	2.2		kΩ
RF type						
Video carrier frequency accuracy	F _p	F _p (US3ch): 61.25MHz X'tal accuracy 30ppm	-25		25	kHz
Video carrier frequency stability	F _{pt}	X'tal accuracy 30ppm Ta = 4°C to 38°C	-25		25	kHz
Video carrier output US	P _{us}	No signal (Note 1)	85.5	87.5	89.5	dBμ
Audio carrier output ratio	P/S	S: f _p + 4.5MHz	14.5	16	17.5	dB
Audio 2 nd harmonic distortion	P/S2	S2: f _p + 2 × 4.5MHz	50	65		dB
Audio 3 rd harmonic distortion	P/S3	S3: f _p + 3 × 4.5MHz	45	55		dB
Chroma beat	P/CB	V _{in} = 3.58MHz, 0.6V _{p-p} CB: f _p + 920kHz	65	74		dB
Video harmonic distortion	P/V2	V _{in} = 1MHz, 1V _{p-p} V2: f _p + 2MHz	45	72		dB
Video type						
Video modulation	M _p	V _{in} = Stair step, 1V _{p-p}	75	80	85	%
White clip level	W _{CL}	V _{in} = Stair step, 1.5V _{p-p}	90	95	99	%
Differential gain	D _G	V _{in} = 10-Stair step, 1V _{p-p} (Note 2)	-5		5	%
Differential phase	D _p	V _{in} = 10-Stair step, 1V _{p-p} (Note 2)	-5		5	°C
Video signal frequency response	R _{fV}	V _{in} = CW, 1V _{p-p} 0.75 MHz to 3.75MHz	-1.1	-0.4	0.3	dB
Video S/N	V _{S/N}	V _{in} = 50% 4.2MHz LPF ON		50		dB
Audio type						
Audio carrier frequency accuracy	F _s	X'tal accuracy 30ppm	-5		5	kHz
Audio modulation	M _s	A _{in} = 1kHz, 1V _{p-p} (Note 3)	90	100	110	%
Maximum audio modulation	M _{smx}	THD < 3%	400			%
Audio distortion	THD	A _{in} = 1 kHz, 1V _{p-p}		0.4	2	%
Audio S/N	A _{S/N}	A _{in} = 1 kHz, 1V _{p-p} V _{in} = Color bar, 1V _{p-p}	45	50		dB

Note 1: 9.5dB added to the R_{FOUT} value measured with a spectrum analyzer of the input impedance of 50Ω.

Note 2: Difference between 1 stair step and 8 stair step of 10 stair step.

Note 3: 100% = ±25kHz modulation.

Package Dimensions

unit : mm
3178B

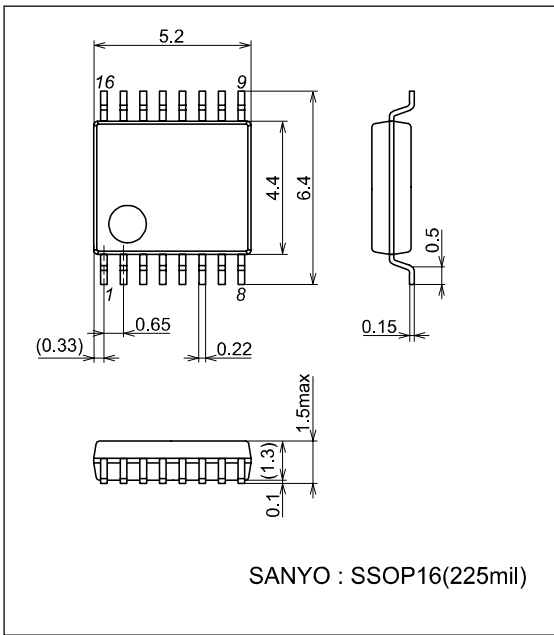

Block Diagram

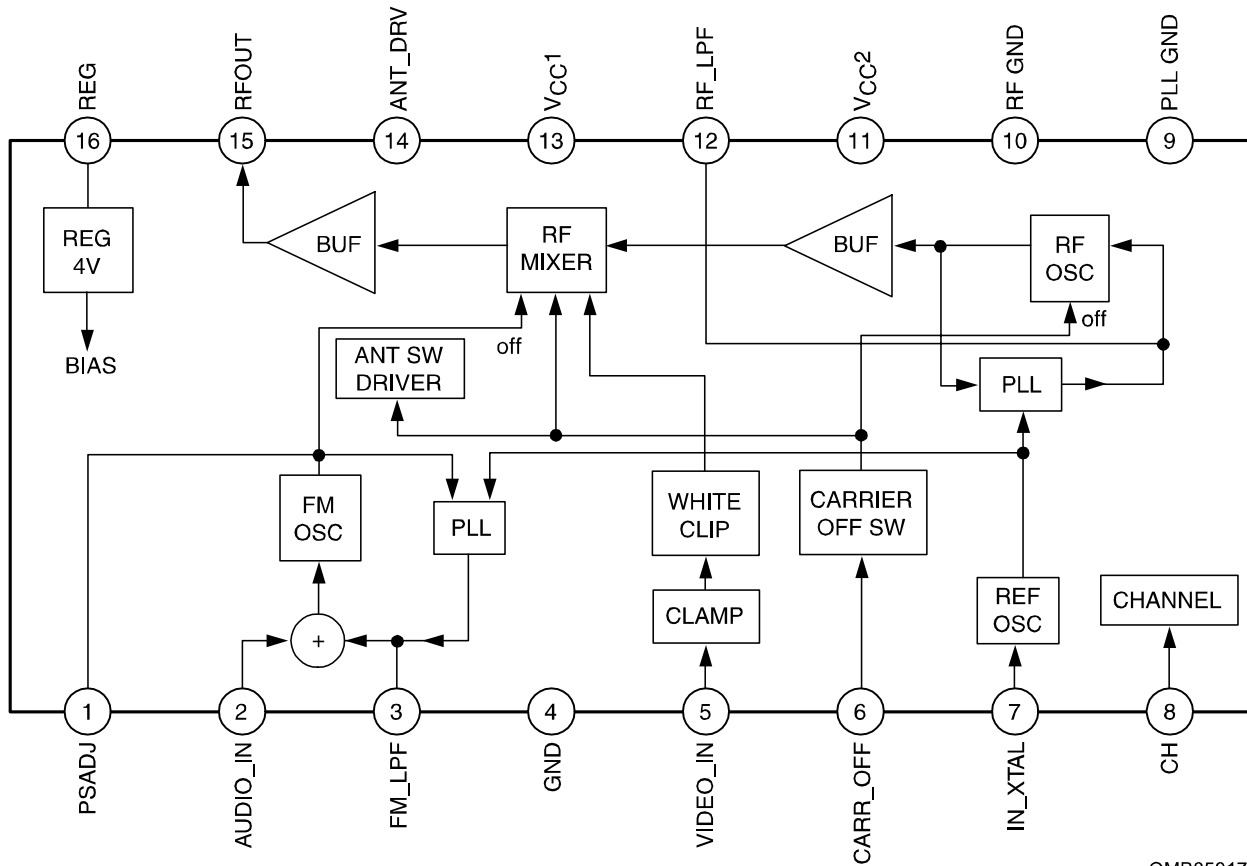

OMB05017

LA7700V

Pin equivalent circuit

Pin No.	Symbol	Voltage	Circuit	Remarks
1	P/S ADJ	2.7		Capacitor and additionally a Resistor may inserted between the circuit and GND attenuate the audio inter-carrier level.
2	AUDIO IN	0		FM audio Input.
3	FM LPF	2.2		Control pin of output FM oscillator for the PLL phase detector charge pump.
4	GND	0		
5	VIDEO IN	2.6		Video Input Clamped with sink chip.
6	CARR OFF	-		Hi:14pin Hi RF Operating Lo:14pin Lo RF Stop

Continued on next page.

LA7700V

Continued from preceding page.

Pin No.	Symbol	Voltage	Circuit	Remarks
7	IN XTAL	3.5		<p>4MHz oscillator inserted between the circuit and GND. External input of the 4MHz signal possible. Insertion of about 270kΩ resistor between the circuit and GND ensures compatibility with 3.58MHz of VTR chroma sub-carrier.</p> <p>Insertion of about 270kΩ resistor between the circuit and V_{CC} ensures compatibility with 27MHz of D-STB reference.</p>
8	CH	1.7		<p>CH selector pin</p> <p>US3: 4.2V or more</p> <p>US4: 2.7V to 3.8V</p>
9	PLL GND	0		PLL type GND
10	RF GND	0		RF type GND
11	V _{CC} ²	5.0		RF VCO type V _{CC}
12	RF LPF	2.6		Control pin of output RF oscillator for the PLL phase detector charge pump.

Continued on next page.

LA7700V

Continued from preceding page.

Pin No.	Symbol	Voltage	Circuit	Remarks
13	VCC1	5.0		VCC
14	ANT DRV	3.5		Antenna SW driver pin. 15mA drive.
15	RF OUT	3.0		RF mixed signal output.
16	REG	3.9		Regulator output.

LA77000V

Test Circuit

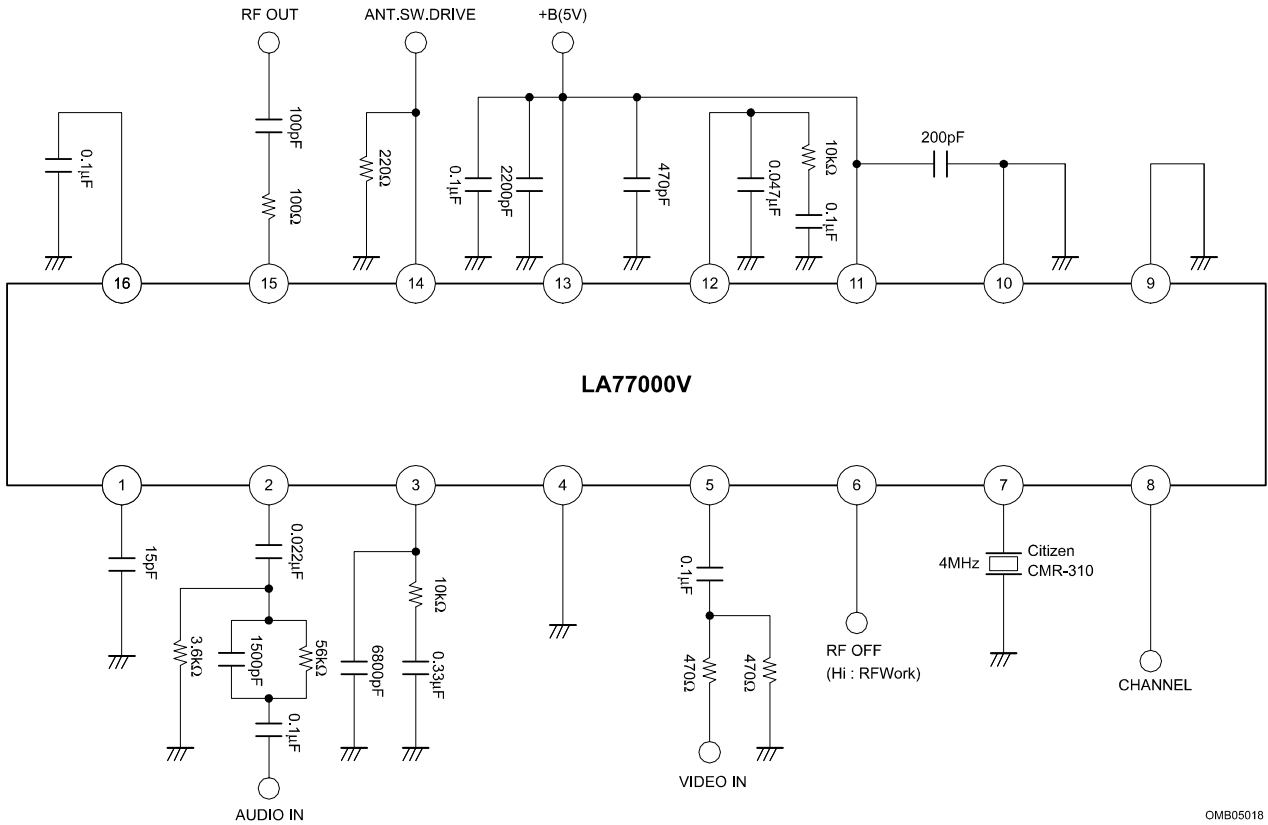

Sample Application Circuit 1 (USch) for VCR

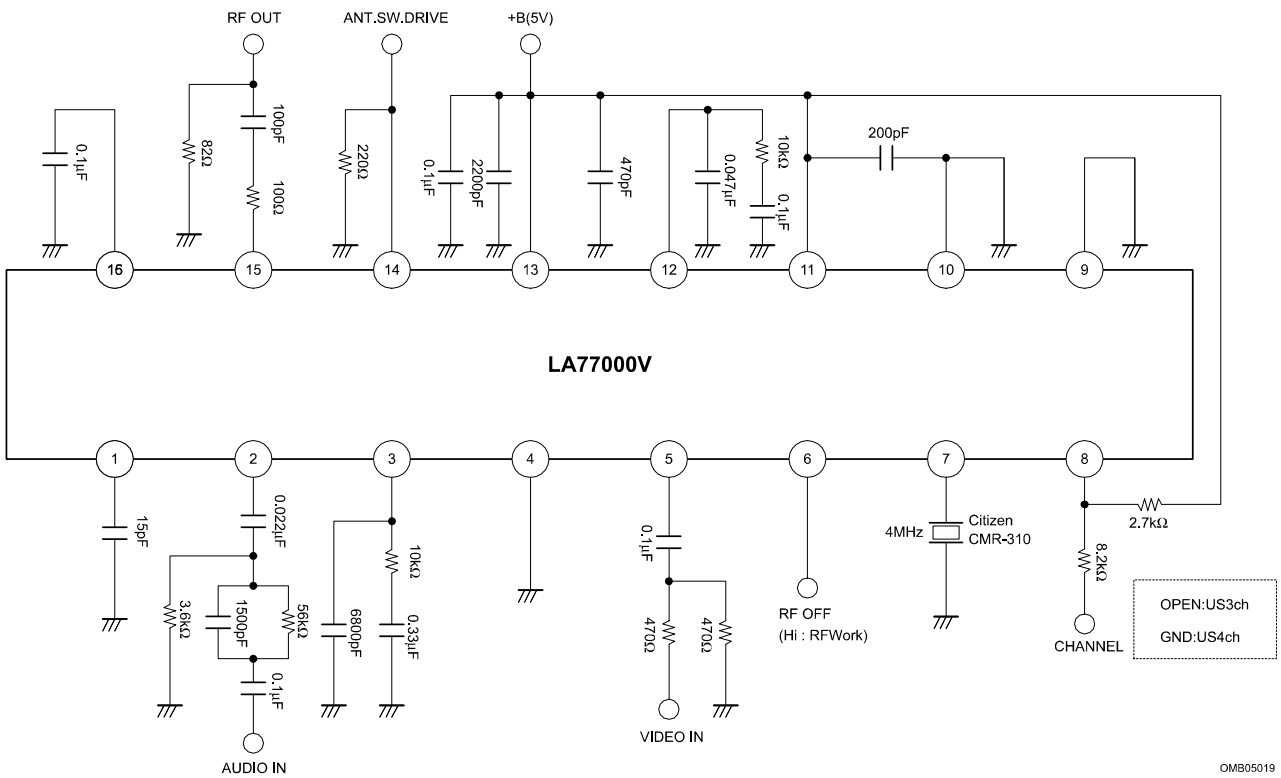

LA7700V

Sample Application Circuit 2 (USch) for STB

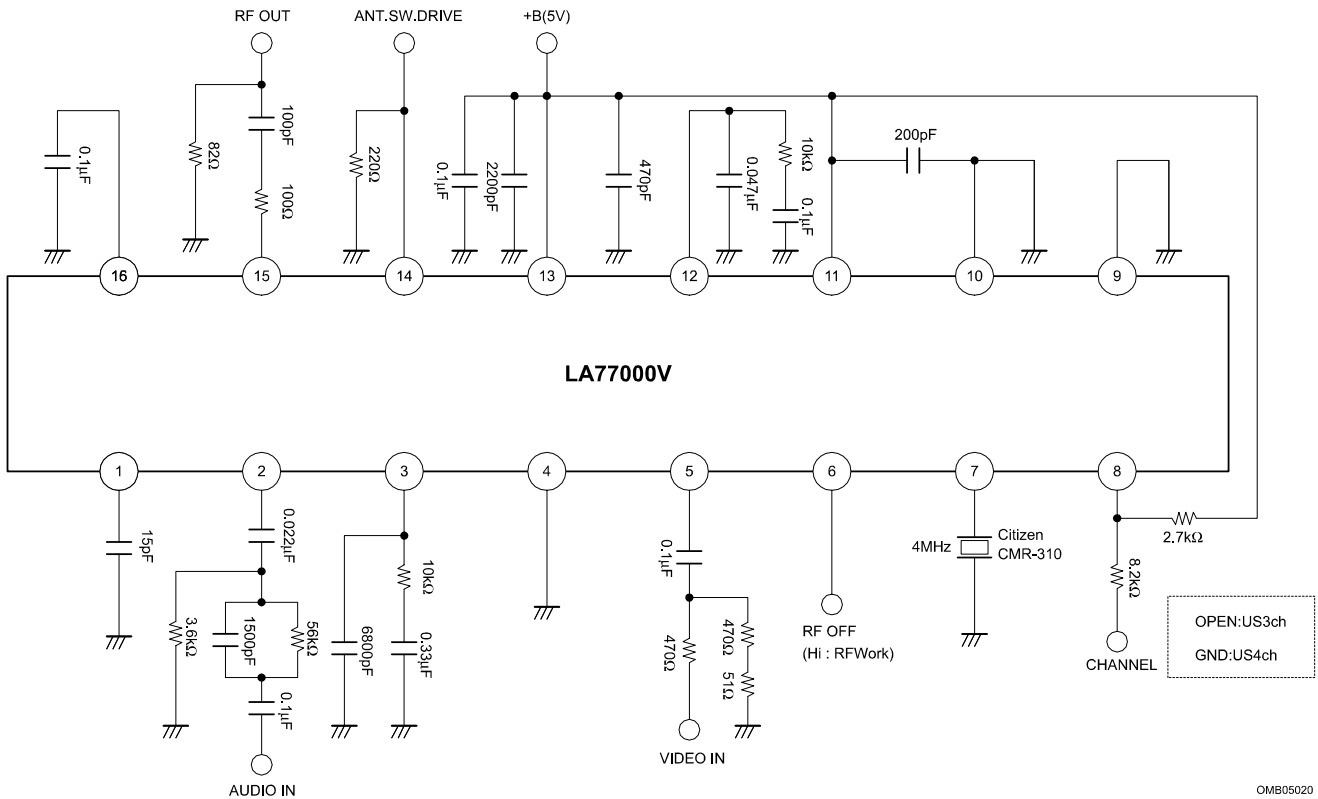

OMB05020

■ Specifications of any and all SANYO Semiconductor products described or contained herein stipulate the performance, characteristics, and functions of the described products in the independent state, and are not guarantees of the performance, characteristics, and functions of the described products as mounted in the customer's products or equipment. To verify symptoms and states that cannot be evaluated in an independent device, the customer should always evaluate and test devices mounted in the customer's products or equipment.

■ SANYO Semiconductor Co., Ltd. strives to supply high-quality high-reliability products. However, any and all semiconductor products fail with some probability. It is possible that these probabilistic failures could give rise to accidents or events that could endanger human lives, that could give rise to smoke or fire, or that could cause damage to other property. When designing equipment, adopt safety measures so that these kinds of accidents or events cannot occur. Such measures include but are not limited to protective circuits and error prevention circuits for safe design, redundant design, and structural design.

■ In the event that any or all SANYO Semiconductor products (including technical data, services) described or contained herein are controlled under any of applicable local export control laws and regulations, such products must not be exported without obtaining the export license from the authorities concerned in accordance with the above law.

■ No part of this publication may be reproduced or transmitted in any form or by any means, electronic or mechanical, including photocopying and recording, or any information storage or retrieval system, or otherwise, without the prior written permission of SANYO Semiconductor Co., Ltd.

■ Any and all information described or contained herein are subject to change without notice due to product/technology improvement, etc. When designing equipment, refer to the "Delivery Specification" for the SANYO Semiconductor product that you intend to use.

■ Information (including circuit diagrams and circuit parameters) herein is for example only; it is not guaranteed for volume production. SANYO Semiconductor believes information herein is accurate and reliable, but no guarantees are made or implied regarding its use or any infringements of intellectual property rights or other rights of third parties.

This catalog provides information as of September, 2005. Specifications and information herein are subject to change without notice.