



RE46C102

CMOS Dual H-Bridge Driver Product Specification

General Description

The RE46C102 is a dual H-bridge driver with 35mA drive current and 16V V_{BB} maximum driver supply voltage. A separate low-side driver ground connection, V_{SS} , is provided for current monitoring of each H-bridge driver. Each driver has two control inputs:

ENABLE which enables the high-side drivers and therefore connects the driver supply to the motor output. This input can be used for pulse-width modulation.

PHASE which is used to reverse the motor polarity.

All control inputs are CMOS and TTL compatible and the logic section operates at $V_{DD}=5V$.

Features

- Typical Quiescent Current < 1uA
- Output Current of 35mA
- Output Voltage to 16V
- Internal Clamp Diodes
- Available in Standard Packaging or RoHS compliant Pb free packaging

Pin Configuration

16 Lead Plastic DIP

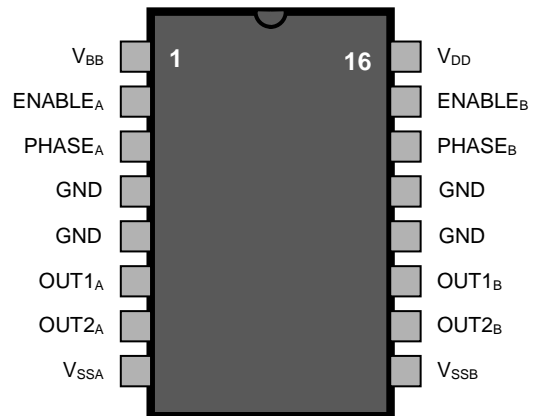

Absolute maximum ratings

Supply Voltage V_{DD}	-5V to +17V
Output Supply Voltage V_{bb}	V_{DD} to +17V
Input voltage Range V_{in}	-3V to $V_{DD}+3V$
Input Current I_{in}	10mA
Operating Temperature	-40°C to 85°C
Storage Temperature.....	-55°C to 150°C
Continuous Output Current	80mA

Stresses beyond those listed under Absolute Maximum Ratings may cause permanent damage to the device. These are stress ratings only and operation at these conditions for extended periods may affect device reliability.

This product utilizes CMOS technology with static protection; however proper ESD prevention procedures should be used when handling this product. Damage can occur when exposed to extremely high static electrical charge

RE46C102

CMOS Dual H-Bridge Driver
Product Specification



R&E International

Electrical Characteristics at $T_A = -40^{\circ}\text{C}$ to $+85^{\circ}\text{C}$, $V_{BB} = 8\text{V}$, $V_{DD} = 5\text{V}$, $V_{SS} = 0\text{V}$ (unless otherwise noted).

Characteristic	Symbol	Conditions	min	typ	max	unit
Logic Supply	V_{DD}		4.75	5	15	V
Logic Quiescent Current	I_{DDs}	$V_{in}=V_{DD}$ or V_{SS}		0.01	10	μA
Driver Supply	V_{BB}		V_{DD}		16	V
Driver Quiescent Current	I_{BBS}	No Load		0.1	20	μA
Output Leakage Current	I_{OUTS}	ENABLE = Lo PHASE = Lo $V_{OUT1} = V_{BB}$ or V_{SS}			± 10	μA
		ENABLE = Lo PHASE = Hi $V_{OUT2} = V_{BB}$ or V_{SS}			± 10	μA
Output High Voltage	V_{OH}	ENABLE = Hi $I_{OUT} = -35\text{mA}$	7.1	7.45		V
Output Low Voltage	V_{OL}	ENABLE = Hi $I_{OUT} = +35\text{mA}$		0.55	0.9	V
Source Driver Rise Time	t_r	$I_{OUT} = -35\text{mA}$		15		ns
Source Driver Fall Time	t_f	$I_{OUT} = -35\text{mA}$		30		ns
Clamp Diode Forward V	V_F	$I_F = 35\text{mA}$		0.8	1.8	V
Input Logic Levels	V_{in}	Hi	2.4	1.5		V
		Low		1.5	0.8	V
Logic Input Current	$I_{ENABLE/PHASE}$				100	nA
Delay Time	t_{DHi}	ENABLE to Source Drivers		80		ns
	t_{DLo}	ENABLE to Source Drivers		120		ns
Deadtime	t_D	Delay from Source Turn-On to Sink Turn-On	75	300		ns

Functional Diagram of one H-Bridge Driver

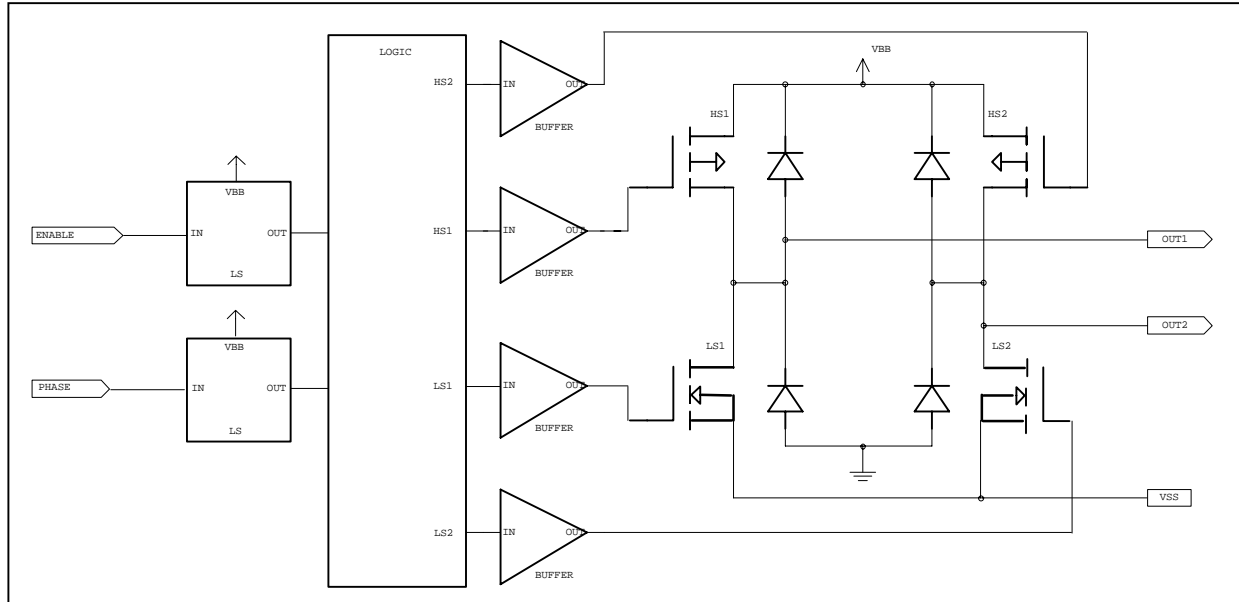

R&E INTERNATIONAL, Inc. reserves the right to make changes without further notice to any products herein to improve reliability, function or design.

R&E INTERNATIONAL, Inc. does not assume any liability arising out of the application or use of any product or circuit described herein; neither does it convey any license under its patent rights, nor the rights of others.

R&E INTERNATIONAL, Inc. products are not authorized for use as critical components in life support devices or systems without the express written approval of the President of **R&E INTERNATIONAL, Inc.** Life support devices or systems are devices or systems which are intended for surgical implant into the body to support or sustain life, and whose failure to perform, when properly used in accordance with instructions for use provided in the labeling, can be reasonably expected to result in a significant injury to the user. A critical component is any component of a life support device or system whose failure to perform can be reasonably expected to cause the failure of the life support device or system, or to affect its safety or effectiveness.