

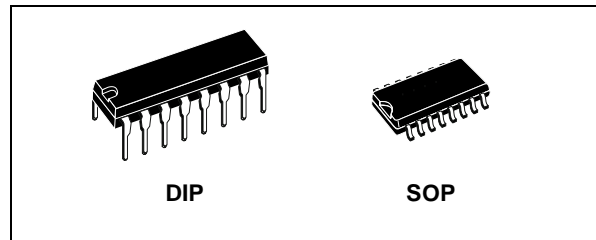

# HCF4020B

## RIPPLE-CARRY BINARY COUNTER/DIVIDERS 14 STAGE

- MEDIUM SPEED OPERATION:  
16MHz (Typ.) at  $V_{DD} = 10V$
- FULLY STATIC OPERATION
- COMMON RESET
- BUFFERED INPUTS AND OUTPUTS
- STANDARDIZED SYMMETRICAL OUTPUT CHARACTERISTICS
- QUIESCENT CURRENT SPECIFIED UP TO 20V
- 5V, 10V AND 15V PARAMETRIC RATINGS
- INPUT LEAKAGE CURRENT  
 $I_l = 100nA$  (MAX) AT  $V_{DD} = 18V$   $T_A = 25^\circ C$
- 100% TESTED FOR QUIESCENT CURRENT



### ORDER CODES

PACKAGE	TUBE	T & R
DIP	HCF4020BEY	
SOP	HCF4020BM1	HCF4020M013TR

### DESCRIPTION

HCF4020B is a monolithic integrated circuit fabricated in Metal Oxide Semiconductor technology available in DIP and SOP packages. HCF4020B is a ripple carry binary counter. All counter stages are master-slave flip-flops. The state of a counter advances one count on the

negative transition of each input pulse; a high level on the RESET line resets the counter to its all zeros stage. Schmitt trigger action on the input pulse line permits unlimited clock rise and fall times.

All inputs and outputs are buffered.

### PIN CONNECTION

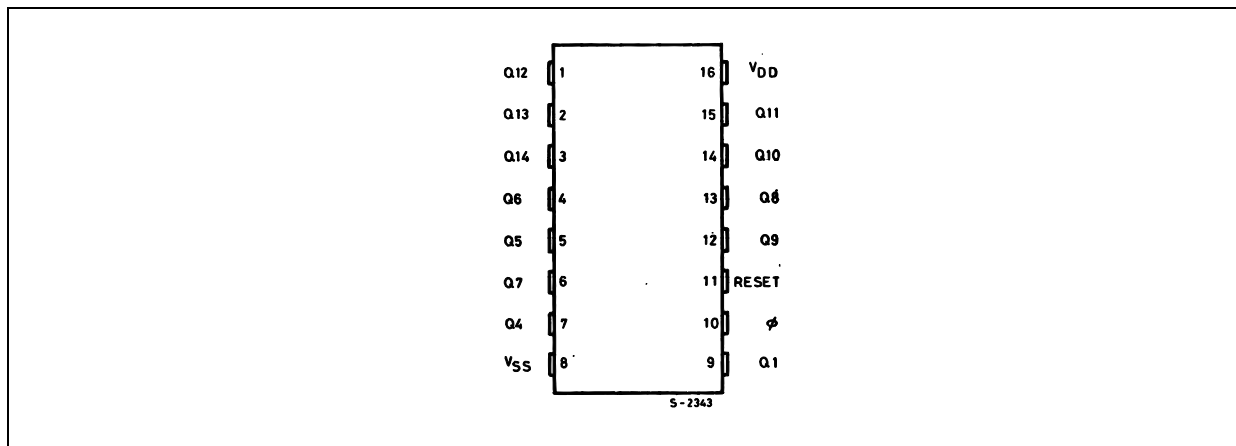

# HCF4020B

## INPUT EQUIVALENT CIRCUIT

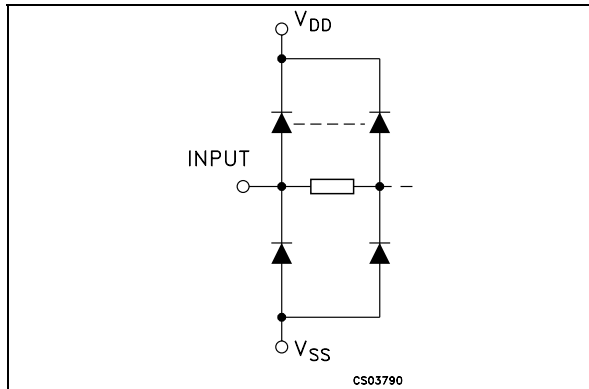

## PIN DESCRIPTION

PIN N°	SYMBOL	NAME AND FUNCTION
9, 7, 5, 4, 6, 13, 12, 14, 15, 1, 2, 3	Q1, Q4 to Q14	14 Buffered Outputs
11	RESET	Reset Input
10	$\Phi$	Input Pulses
8	$V_{SS}$	Negative Supply Voltage
16	$V_{DD}$	Positive Supply Voltage

## FUNCTIONAL DIAGRAM

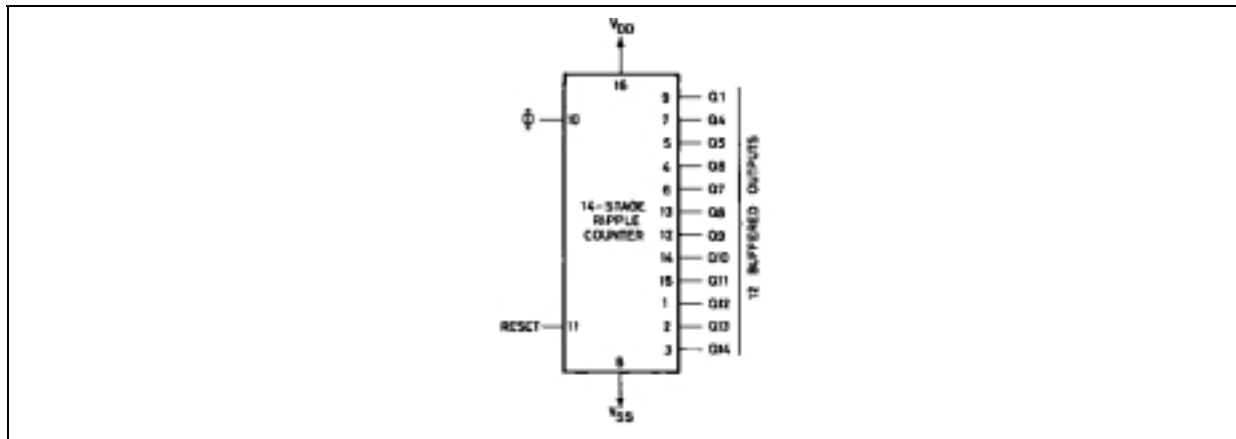

## TRUTH TABLE

$\Phi$	RESET	OUTPUT STATE
X	H	ALL OUTPUTS = "L"
	L	NO CHANGE
	L	ADVANCE TO NEXT STATE

X : Don't Care

## LOGIC DIAGRAM

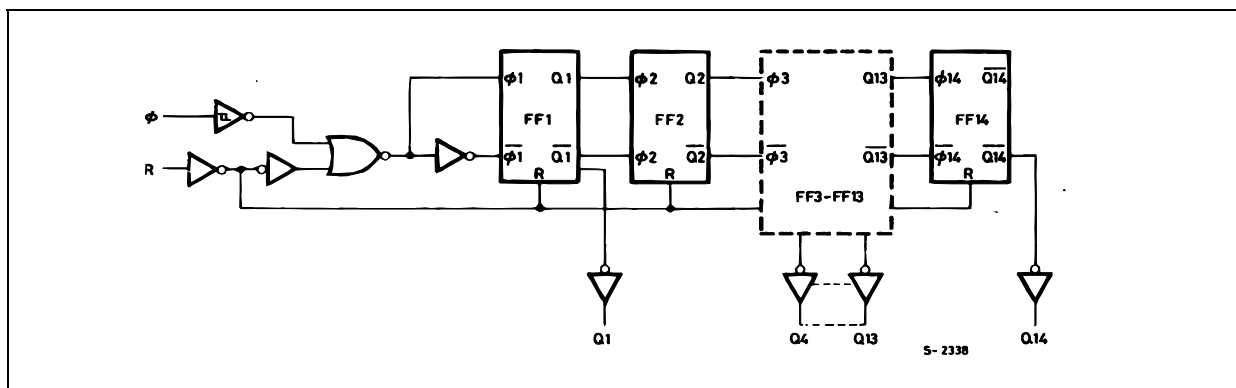

**ABSOLUTE MAXIMUM RATINGS**

Symbol	Parameter	Value	Unit
$V_{DD}$	Supply Voltage	-0.5 to +22	V
$V_I$	DC Input Voltage	-0.5 to $V_{DD} + 0.5$	V
$I_I$	DC Input Current	$\pm 10$	mA
$P_D$	Power Dissipation per Package	200	mW
	Power Dissipation per Output Transistor	100	mW
$T_{op}$	Operating Temperature	-55 to +125	°C
$T_{stg}$	Storage Temperature	-65 to +150	°C

Absolute Maximum Ratings are those values beyond which damage to the device may occur. Functional operation under these conditions is not implied.

All voltage values are referred to  $V_{SS}$  pin voltage.

**RECOMMENDED OPERATING CONDITIONS**

Symbol	Parameter	Value	Unit
$V_{DD}$	Supply Voltage	3 to 20	V
$V_I$	Input Voltage	0 to $V_{DD}$	V
$T_{op}$	Operating Temperature	-55 to 125	°C

DC SPECIFICATIONS

Symbol	Parameter	Test Condition				Value						Unit	
		V <sub>I</sub> (V)	V <sub>O</sub> (V)	I <sub>OL</sub>   ( $\mu$ A)	V <sub>DD</sub> (V)	T <sub>A</sub> = 25°C			-40 to 85°C		-55 to 125°C		
						Min.	Typ.	Max.	Min.	Max.	Min.		Max.
I <sub>L</sub>	Quiescent Current	0/5			5		0.04	5		150		150	$\mu$ A
		0/10			10		0.04	10		300		300	
		0/15			15		0.04	20		600		600	
		0/20			20		0.08	100		3000		3000	
V <sub>OH</sub>	High Level Output Voltage	0/5		<1	5	4.95			4.95		4.95		V
		0/10		<1	10	9.95			9.95		9.95		
		0/15		<1	15	14.95			14.95		14.95		
V <sub>OL</sub>	Low Level Output Voltage	5/0		<1	5			0.05		0.05		0.05	V
		10/0		<1	10			0.05		0.05		0.05	
		15/0		<1	15			0.05		0.05		0.05	
V <sub>IH</sub>	High Level Input Voltage		0.5/4.5	<1	5	3.5			3.5		3.5		V
			1/9	<1	10	7			7		7		
			1.5/13.5	<1	15	11			11		11		
V <sub>IL</sub>	Low Level Input Voltage		4.5/0.5	<1	5			1.5		1.5		1.5	V
			9/1	<1	10			3		3		3	
			13.5/1.5	<1	15			4		4		4	
I <sub>OH</sub>	Output Drive Current	0/5	2.5	<1	5	-1.36	-3.2		-1.1		-1.1		mA
		0/5	4.6	<1	5	-0.44	-1		-0.36		-0.36		
		0/10	9.5	<1	10	-1.1	-2.6		-0.9		-0.9		
		0/15	13.5	<1	15	-3.0	-6.8		-2.4		-2.4		
I <sub>OL</sub>	Output Sink Current	0/5	0.4	<1	5	0.44	1		0.36		0.36		mA
		0/10	0.5	<1	10	1.1	2.6		0.9		0.9		
		0/15	1.5	<1	15	3.0	6.8		2.4		2.4		
I <sub>I</sub>	Input Leakage Current	0/18	Any Input		18		$\pm 10^{-5}$	$\pm 0.1$		$\pm 1$		$\pm 1$	$\mu$ A
C <sub>I</sub>	Input Capacitance		Any Input				5	7.5					pF

The Noise Margin for both "1" and "0" level is: 1V min. with V<sub>DD</sub>=5V, 2V min. with V<sub>DD</sub>=10V, 2.5V min. with V<sub>DD</sub>=15V

**DYNAMIC ELECTRICAL CHARACTERISTICS** ( $T_{amb} = 25^{\circ}\text{C}$ ,  $C_L = 50\text{pF}$ ,  $R_L = 200\text{K}\Omega$ ,  $t_r = t_f = 20\text{ ns}$ )

Symbol	Parameter	Test Condition		Value (*)			Unit
		$V_{DD}$ (V)		Min.	Typ.	Max.	
<b>INPUT-PULSE OPERATION</b>							
$t_{PLH}$ $t_{PHL}$	Propagation Delay Time ( $\emptyset$ to Q1 Out)	5			180	360	ns
		10			80	160	
		15			65	130	
$t_{PLH}$ $t_{PHL}$	Propagation Delay Time ( $Q_n$ to $Q_{n+1}$ )	5			100	200	ns
		10			40	80	
		15			30	60	
$t_{THL}$ $t_{TLH}$	Transition Time	5			100	200	ns
		10			50	100	
		15			40	80	
$t_W$	Minimum Input Pulse Width	5			70	140	ns
		10			30	60	
		15			20	40	
$t_r$ , $t_f$	Input Pulse Rise and Fall Time	5		unlimited			$\mu\text{s}$
		10					
		15					
$f_{max}$	Maximum Clock Input Frequency	5		3.5	7		MHz
		10		8	16		
		15		12	24		
<b>RESET OPERATION</b>							
$t_{PHL}$	Propagation Delay Time	5			140	280	ns
		10			60	120	
		15			50	100	
$t_W$	Minimum Reset Pulse Width	5			100	200	ns
		10			40	80	
		15			30	60	
$t_{REM}$	Reset Removal Time	5			175	350	ns
		10			75	150	
		15			50	100	

(\*) Typical temperature coefficient for all  $V_{DD}$  value is 0.3%/°C.

TEST CIRCUIT

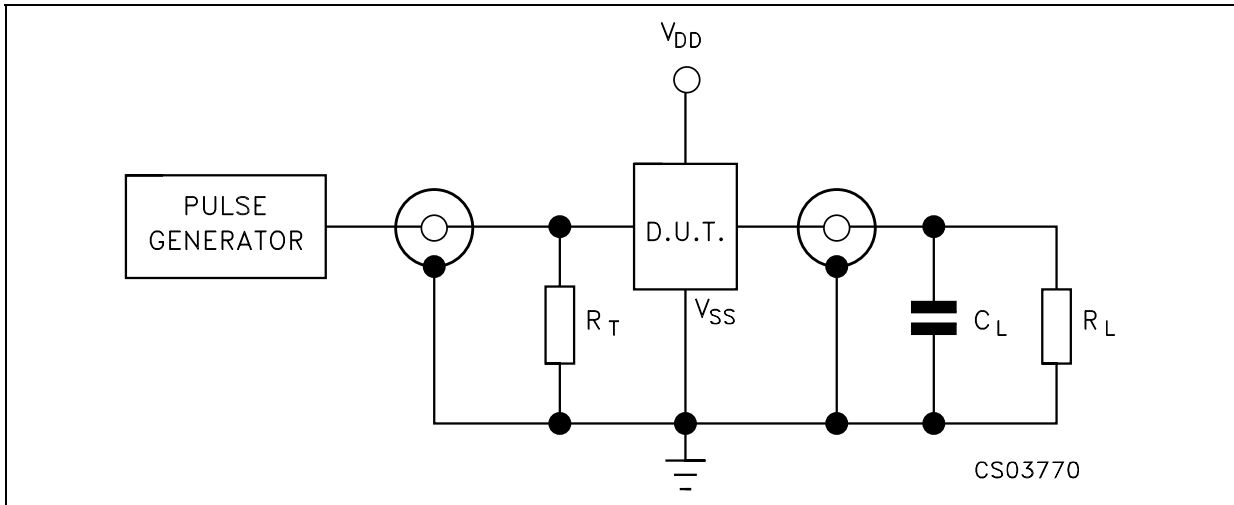

$C_L = 50\text{pF}$  or equivalent (includes jig and probe capacitance)  
 $R_L = 200\text{K}\Omega$   
 $R_T = Z_{OUT}$  of pulse generator (typically  $50\Omega$ )

**WAVEFORM 1: MINIMUM PULSE WIDTH (RESET) AND REMOVAL TIME (RESET TO  $\Phi$ )** ( $f=1\text{MHz}$ ; 50% duty cycle)

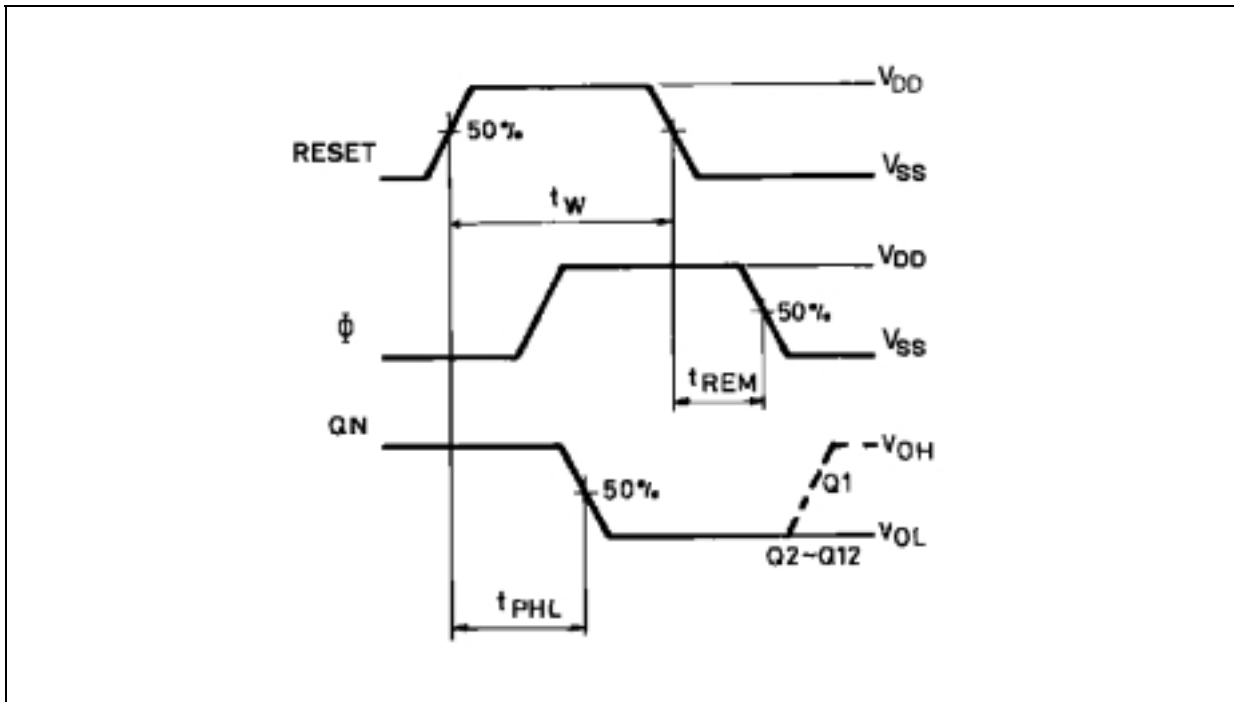

WAVEFORM 2: PROPAGATION DELAY TIME (f=1MHz; 50% duty cycle)

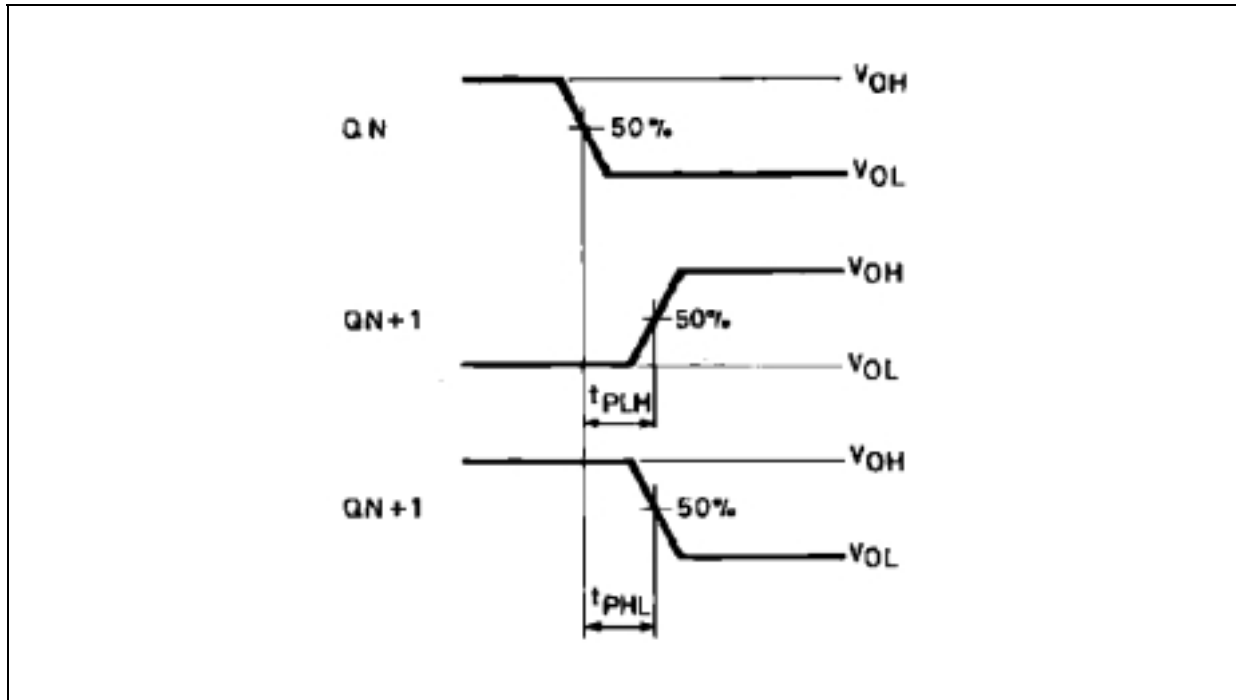

WAVEFORM 3: PROPAGATION DELAY TIME, MINIMUM PULSE WIDTH ( $\Phi$ ) (f=1MHz; 50% duty cycle)

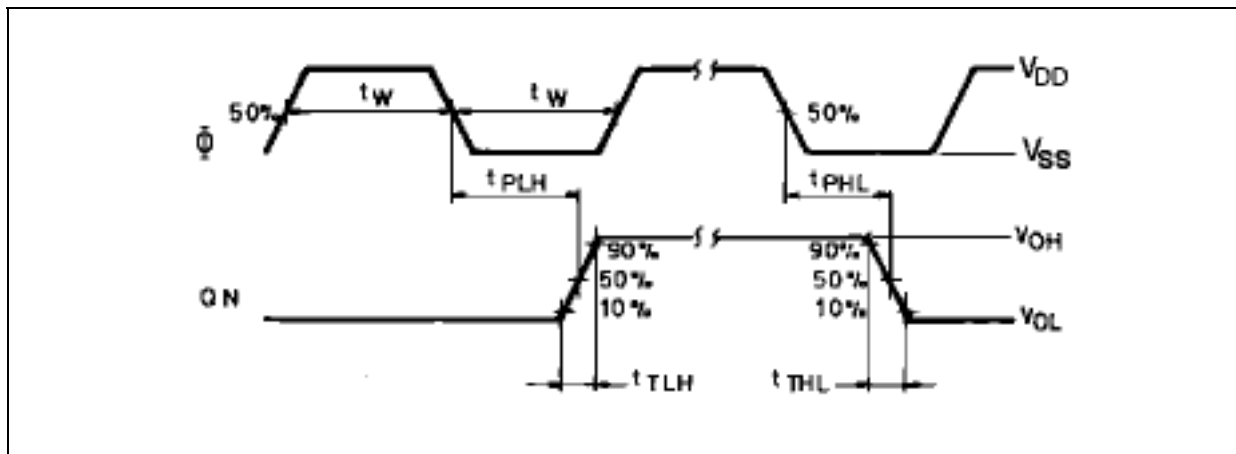

**Plastic DIP-16 (0.25) MECHANICAL DATA**

DIM.	mm.			inch		
	MIN.	TYP	MAX.	MIN.	TYP.	MAX.
a1	0.51			0.020		
B	0.77		1.65	0.030		0.065
b		0.5			0.020	
b1		0.25			0.010	
D			20			0.787
E		8.5			0.335	
e		2.54			0.100	
e3		17.78			0.700	
F			7.1			0.280
I			5.1			0.201
L		3.3			0.130	
Z			1.27			0.050

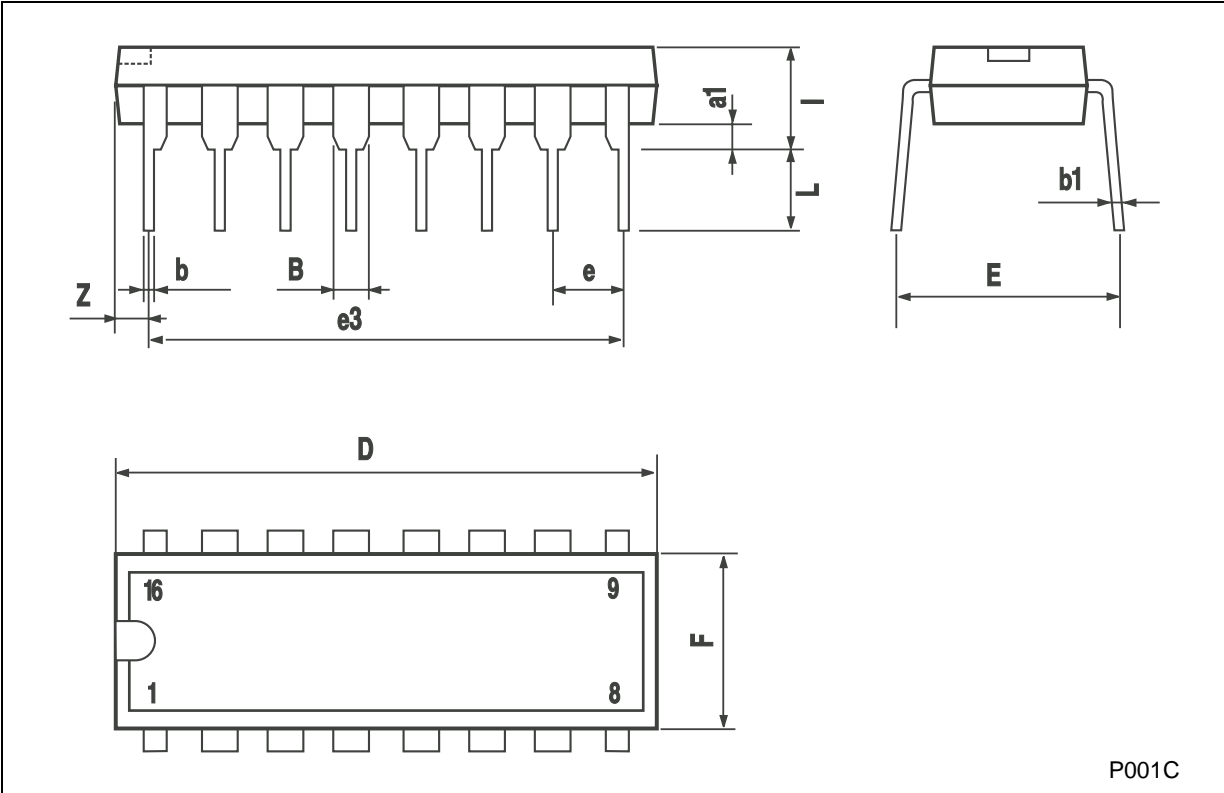

P001C





## SO-16 MECHANICAL DATA

DIM.	mm.			inch		
	MIN.	TYP.	MAX.	MIN.	TYP.	MAX.
A			1.75			0.068
a1	0.1		0.2	0.004		0.008
a2			1.65			0.064
b	0.35		0.46	0.013		0.018
b1	0.19		0.25	0.007		0.010
C		0.5			0.019	
c1	45° (typ.)					
D	9.8		10	0.385		0.393
E	5.8		6.2	0.228		0.244
e		1.27			0.050	
e3		8.89			0.350	
F	3.8		4.0	0.149		0.157
G	4.6		5.3	0.181		0.208
L	0.5		1.27	0.019		0.050
M			0.62			0.024
S	8			° (max.)		

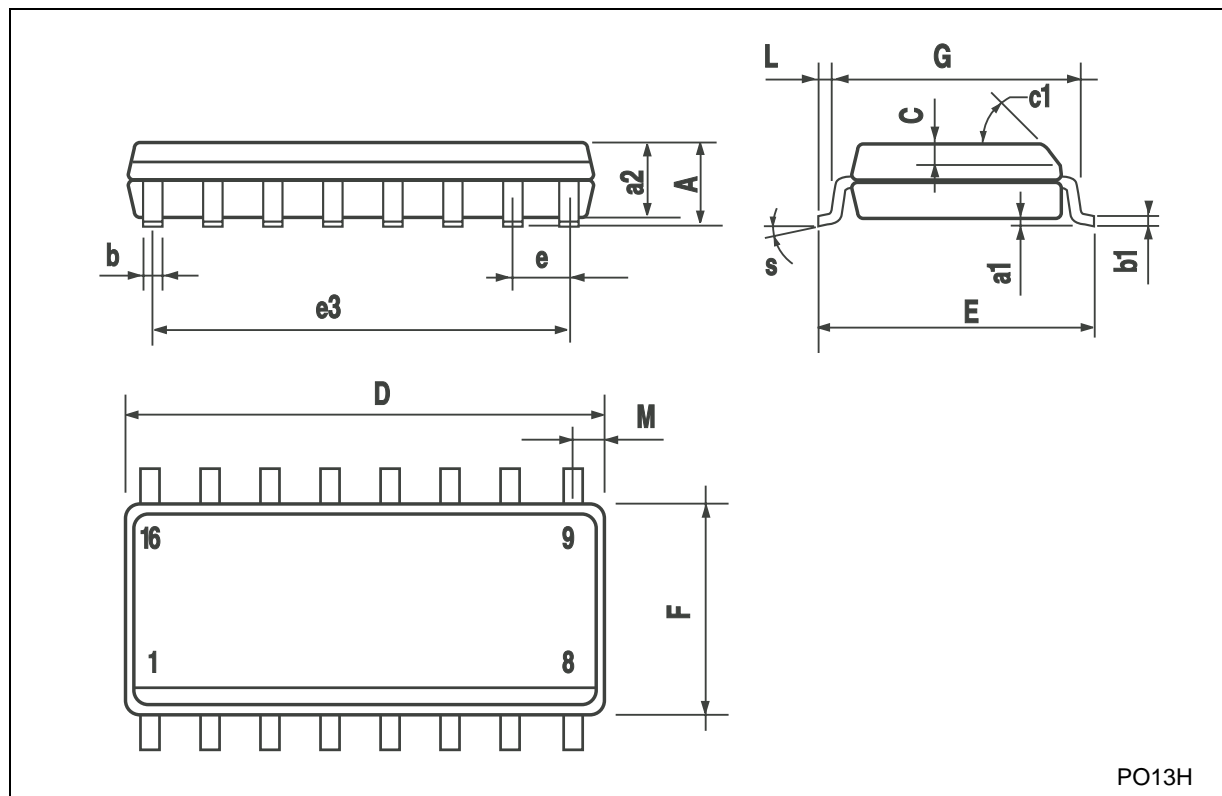

PO13H

**Tape & Reel SO-16 MECHANICAL DATA**

DIM.	mm.			inch		
	MIN.	TYP	MAX.	MIN.	TYP.	MAX.
A			330			12.992
C	12.8		13.2	0.504		0.519
D	20.2			0.795		
N	60			2.362		
T			22.4			0.882
Ao	6.45		6.65	0.254		0.262
Bo	10.3		10.5	0.406		0.414
Ko	2.1		2.3	0.082		0.090
Po	3.9		4.1	0.153		0.161
P	7.9		8.1	0.311		0.319

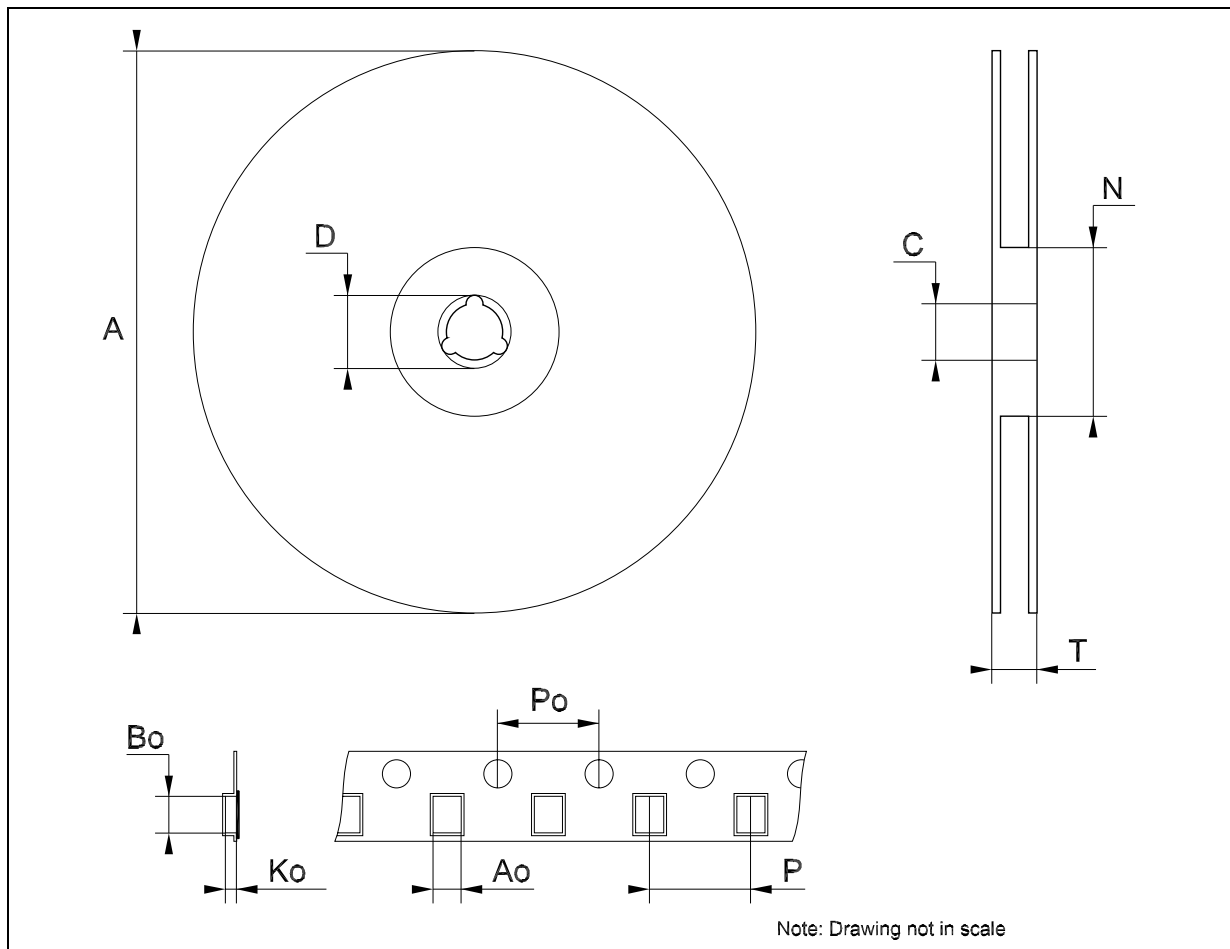

Information furnished is believed to be accurate and reliable. However, STMicroelectronics assumes no responsibility for the consequences of use of such information nor for any infringement of patents or other rights of third parties which may result from its use. No license is granted by implication or otherwise under any patent or patent rights of STMicroelectronics. Specifications mentioned in this publication are subject to change without notice. This publication supersedes and replaces all information previously supplied. STMicroelectronics products are not authorized for use as critical components in life support devices or systems without express written approval of STMicroelectronics.

The ST logo is a registered trademark of STMicroelectronics  
All other names are the property of their respective owners

© 2004 STMicroelectronics - All Rights Reserved  
STMicroelectronics GROUP OF COMPANIES

Australia - Belgium - Brazil - Canada - China - Czech Republic - Finland - France - Germany - Hong Kong - India - Israel - Italy - Japan -  
Malaysia - Malta - Morocco - Singapore - Spain - Sweden - Switzerland - United Kingdom - United States.

<http://www.st.com>