

RoHS & Pb-Free Product

Typical Applications

- 3V GSM Cellular Handsets
- 3V Dual-Band/Triple-Band Handsets
- GPRS Compatible
- Commercial and Consumer Systems
- Portable Battery-Powered Equipment
- FM Radio Applications: 150MHz/220MHz/450MHz/865MHz/915MHz

Product Description

The RF5110G is a high-power, high-efficiency power amplifier module offering high performance in GSM OR GPRS applications. The device is manufactured on an advanced GaAs HBT process, and has been designed for use as the final RF amplifier in GSM hand-held digital cellular equipment and other applications in the 800MHz to 950MHz band. On-board power control provides over 70dB of control range with an analog voltage input, and provides power down with a logic "low" for standby operation. The device is self-contained with 50Ω input and the output can be easily matched to obtain optimum power and efficiency characteristics. The RF5110G can be used together with the RF5111 for dual-band operation. The device is packaged in an ultra-small 3mmx3mmx1mm plastic package, minimizing the required board space.

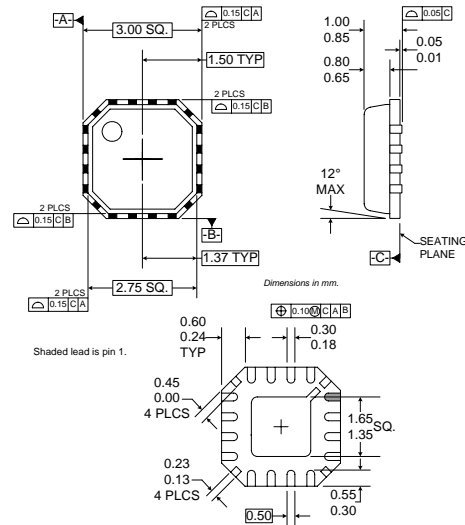

Package Style: QFN, 16-Pin, 3x3

Optimum Technology Matching® Applied

- | | | |
|-------------------------------------|--|---------------------------------------|
| <input type="checkbox"/> Si BJT | <input checked="" type="checkbox"/> GaAs HBT | <input type="checkbox"/> GaAs MESFET |
| <input type="checkbox"/> Si Bi-CMOS | <input type="checkbox"/> SiGe HBT | <input type="checkbox"/> Si CMOS |
| <input type="checkbox"/> InGaP/HBT | <input type="checkbox"/> GaN HEMT | <input type="checkbox"/> SiGe Bi-CMOS |

Features

- Single 2.7V to 4.8V Supply Voltage
- +36dBm Output Power at 3.5V
- 32dB Gain with Analog Gain Control
- 57% Efficiency
- 800MHz to 950MHz Operation
- Supports GSM and E-GSM

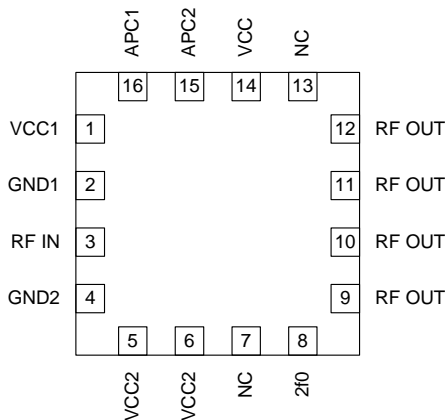

Functional Block Diagram

Ordering Information

RF5110G 3V GSM Power Amplifier
 RF5110GPCBA-410 Fully Assembled Evaluation Board

RF Micro Devices, Inc.
 7628 Thorndike Road
 Greensboro, NC 27409, USA

Tel (336) 664 1233
 Fax (336) 664 0454
<http://www.rfmd.com>

RF5110G

Absolute Maximum Ratings

Parameter	Rating	Unit
Supply Voltage	-0.5 to +6.0	V _{DC}
Power Control Voltage (V _{APC1,2})	-0.5 to +3.0	V
DC Supply Current	2400	mA
Input RF Power	+13	dBm
Duty Cycle at Max Power	50	%
Output Load VSWR	10:1	
Operating Case Temperature	-40 to +85	°C
Storage Temperature	-55 to +150	°C



Caution! ESD sensitive device.

RF Micro Devices believes the furnished information is correct and accurate at the time of this printing. RoHS marking based on EU Directive 2002/95/EC (at time of this printing). However, RF Micro Devices reserves the right to make changes to its products without notice. RF Micro Devices does not assume responsibility for the use of the described product(s).

Parameter	Specification			Unit	Condition
	Min.	Typ.	Max.		
Overall					Temp=25°C, V _{CC} =3.6V, V _{APC1,2} =2.8V, P _{IN} =+4.5dBm, Freq=880MHz to 915MHz, 37.5% Duty Cycle, pulse width=1731µs See evaluation board schematic.
Operating Frequency Range		880 to 915		MHz	Using different evaluation board tune.
Usable Frequency Range		800 to 950		MHz	Using different evaluation board tune.
Maximum Output Power	33.8	34.5		dBm	Temp=25°C, V _{CC} =3.6V, V _{APC1,2} =2.8V
	33.1			dBm	Temp=+60°C, V _{CC} =3.3V, V _{APC1,2} =2.8V
Total Efficiency	50	57		%	At P _{OUT,MAX} , V _{CC} =3.6V
		12		%	P _{OUT} =+20dBm
		5		%	P _{OUT} =+10dBm
Input Power for Max Output	+4.5	+7.0	+9.5	dBm	
Output Noise Power			-72	dBm	RBW=100kHz, 925MHz to 935MHz, P _{OUT,MIN} <P _{OUT} <P _{OUT,MAX} , P _{IN,MIN} <P _{IN} <P _{IN,MAX} , V _{CC} =3.3V to 5.0V
			-81	dBm	RBW=100kHz, 935MHz to 960MHz, P _{OUT,MIN} <P _{OUT} <P _{OUT,MAX} , P _{IN,MIN} <P _{IN} <P _{IN,MAX} , V _{CC} =3.3V to 5.0V
Forward Isolation			-22	dBm	V _{APC1,2} =0.3V, P _{IN} =+9.5dBm
Second Harmonic		-20	-7	dBm	P _{IN} =+9.5dBm
Third Harmonic		-25	-7	dBm	P _{IN} =+9.5dBm
All Other Non-Harmonic Spurious			-36	dBm	
Input Impedance		50		Ω	
Optimum Source Impedance		40+j10		Ω	For best noise performance
Input VSWR			2.5:1		P _{OUT,MAX} -5dB<P _{OUT} <P _{OUT,MAX}
			4:1		P _{OUT} <P _{OUT,MAX} -5dB
Output Load VSWR					
Stability	8:1				Spurious<-36dBm, V _{APC1,2} =0.3V to 2.6V, RBW=100kHz
Ruggedness	10:1				No damage
Output Load Impedance		2.6-j1.5		Ω	Load Impedance presented at RF OUT pad
Power Control V _{APC1} V _{APC2}					
Power Control "ON"	2.6			V	Maximum P _{OUT} , Voltage supplied to the input
Power Control "OFF"	0.2	0.5		V	Minimum P _{OUT} , Voltage supplied to the input
Power Control Range	75			dB	V _{APC1,2} =0.2V to 2.6V
Gain Control Slope	5	100	150	dB/V	P _{OUT} =-10dBm to +35dBm
APC Input Capacitance			10	pF	DC to 2MHz
APC Input Current		4.5	5	mA	V _{APC1,2} =2.8V
			25	µA	V _{APC1,2} =0V
Turn On/Off Time			100	ns	V _{APC1,2} =0 to 2.8V

Parameter	Specification			Unit	Condition
	Min.	Typ.	Max.		
Power Supply					
Power Supply Voltage	2.7	3.5	4.8	V	Specifications Nominal operating limits, P _{OUT} <+35dBm With maximum output load VSWR 6:1, P _{OUT} <+35dBm
			5.5	V	
Power Supply Current			2	A	
	15	200	335	mA	DC Current at P _{OUT,MAX} Idle Current, P _{IN} <-30dBm
			1	μA	P _{IN} <-30dBm, V _{APC1,2} =0.2V
			1	μA	P _{IN} <-30dBm, V _{APC1,2} =0.2V, Temp=+85°C

RF5110G

Pin	Function	Description	Interface Schematic
1	VCC1	Power supply for the pre-amplifier stage and interstage matching. This pin forms the shunt inductance needed for proper tuning of the interstage match. Refer to the application schematic for proper configuration. Note that position and value of the components are important.	See pin 3.
2	GND1	Ground connection for the pre-amplifier stage. Keep traces physically short and connect immediately to the ground plane for best performance. It is important for stability that this pin has its own vias to the groundplane, to minimize any common inductance.	See pin 1.
3	RF IN	RF Input. This is a 50Ω input, but the actual impedance depends on the interstage matching network connected to pin 1. An external DC blocking capacitor is required if this port is connected to a DC path to ground or a DC voltage.	
4	GND2	Ground connection for the driver stage. To minimize the noise power at the output, it is recommended to connect this pin with a trace of about 40mil to the ground plane. This will slightly reduce the small signal gain, and lower the noise power. It is important for stability that this pin have its own vias to the ground plane, minimizing common inductance.	See pin 3.
5	VCC2	Power supply for the driver stage and interstage matching. This pin forms the shunt inductance needed for proper tuning of the interstage match. Please refer to the application schematic for proper configuration, and note that position and value of the components are important.	
6	VCC2	Same as pin 5.	
7	NC	Not connected.	
8	2F0	Connection for the second harmonic trap. This pin is internally connected to the RF OUT pins. The bonding wire together with an external capacitor form a series resonator that should be tuned to the second harmonic frequency in order to increase efficiency and reduce spurious outputs.	Same as pin 9.
9	RF OUT	RF Output and power supply for the output stage. Bias voltage for the final stage is provided through this wide output pin. An external matching network is required to provide the optimum load impedance.	
10	RF OUT	Same as pin 9.	Same as pin 9.
11	RF OUT	Same as pin 9.	Same as pin 9.
12	RF OUT	Same as pin 9.	
13	NC	Not connected.	
14	VCC	Power supply for the bias circuits.	
15	APC2	Power Control for the output stage. See pin 16 for more details.	See pin 16.
16	APC1	Power Control for the driver stage and pre-amplifier. When this pin is "low," all circuits are shut off. A "low" is typically 0.5V or less at room temperature. A shunt bypass capacitor is required. During normal operation this pin is the power control. Control range varies from about 1.0V for -10dBm to 2.6V for +35dBm RF output power. The maximum power that can be achieved depends on the actual output matching; see the application information for more details. The maximum current into this pin is 5mA when $V_{APC1}=2.6V$, and 0mA when $V_{APC1}=0V$.	
Pkg Base	GND	Ground connection for the output stage. This pad should be connected to the ground plane by vias directly under the device. A short path is required to obtain optimum performance, as well as to provide a good thermal path to the PCB for maximum heat dissipation.	

Theory of Operation and Application Information

The RF5110G is a three-stage device with 32 dB gain at full power. Therefore, the drive required to fully saturate the output is +3dBm. Based upon HBT (Heterojunction Bipolar Transistor) technology, the part requires only a single positive 3V supply to operate to full specification. Power control is provided through a single pin interface, with a separate Power Down control pin. The final stage ground is achieved through the large pad in the middle of the backside of the package. First and second stage grounds are brought out through separate ground pins for isolation from the output. These grounds should be connected directly with vias to the PCB ground plane, and not connected with the output ground to form a so called “local ground plane” on the top layer of the PCB. The output is brought out through the wide output pad, and forms the RF output signal path.

The amplifier operates in near Class C bias mode. The final stage is “deep AB”, meaning the quiescent current is very low. As the RF drive is increased, the final stage self-biases, causing the bias point to shift up and, at full power, draws about 2000mA. The optimum load for the output stage is approximately 2.6Ω . This is the load at the output collector, and is created by the series inductance formed by the output bond wires, vias, and microstrip, and 2 shunt capacitors external to the part. The optimum load impedance at the RF Output pad is $2.6-j1.5\Omega$. With this match, a 50Ω terminal impedance is achieved. The input is internally matched to 50Ω with just a blocking capacitor needed. This data sheet defines the configuration for GSM operation.

The input is DC coupled; thus, a blocking cap must be inserted in series. Also, the first stage bias may be adjusted by a resistive divider with high value resistors on this pin to V_{PC} and ground. For nominal operation, however, no external adjustment is necessary as internal resistors set the bias point optimally.

VCC1 and VCC2 provide supply voltage to the first and second stage, as well as provides some frequency selectivity to tune to the operating band. Essentially, the bias is fed to this pin through a short microstrip. A bypass capacitor sets the inductance seen by the part, so placement of the bypass cap can affect the frequency of the gain peak. This supply should be bypassed individually with 100pF capacitors before being combined with V_{CC} for the output stage to prevent feedback and oscillations.

The RF OUT pin provides the output power. Bias for the final stage is fed to this output line, and the feed must be capable of supporting the approximately 2A of current required. Care should be taken to keep the losses low in the bias feed and output components. A narrow microstrip line is recommended because DC losses in a bias choke will degrade efficiency and power.

While the part is safe under CW operation, maximum power and reliability will be achieved under pulsed conditions. The data shown in this data sheet is based on a 12.5% duty cycle and a $600\mu s$ pulse, unless specified otherwise.

The part will operate over a 3.0V to 5.0V range. Under nominal conditions, the power at 3.5V will be greater than +34.5dBm at +90°C. As the voltage is increased, however, the output power will increase. Thus, in a system design, the ALC (Automatic Level Control) Loop will back down the power to the desired level. This must occur during operation, or the device may be damaged from too much power dissipation. At 5.0V, over +38dBm may be produced; however, this level of power is not recommended, and can cause damage to the device.

The HBT breakdown voltage is $>20V$, so there are no issue with overvoltage. However, under worst-case conditions, with the RF drive at full power during transmit, and the output VSWR extremely high, a low load impedance at the collector of the output transistors can cause currents much higher than normal. Due to the bipolar nature of the devices, there is no limitation on the amount of current the device will sink, and the safe current densities could be exceeded.

High current conditions are potentially dangerous to any RF device. High currents lead to high channel temperatures and may force early failures. The RF5110G includes temperature compensation circuits in the bias network to stabilize the RF transistors, thus limiting the current through the amplifier and protecting the devices from damage. The same mechanism works to compensate the currents due to ambient temperature variations.

To avoid excessively high currents it is important to control the V_{APC} when operating at supply voltages higher than 4.0V, such that the maximum output power is not exceeded.

Internal Schematic

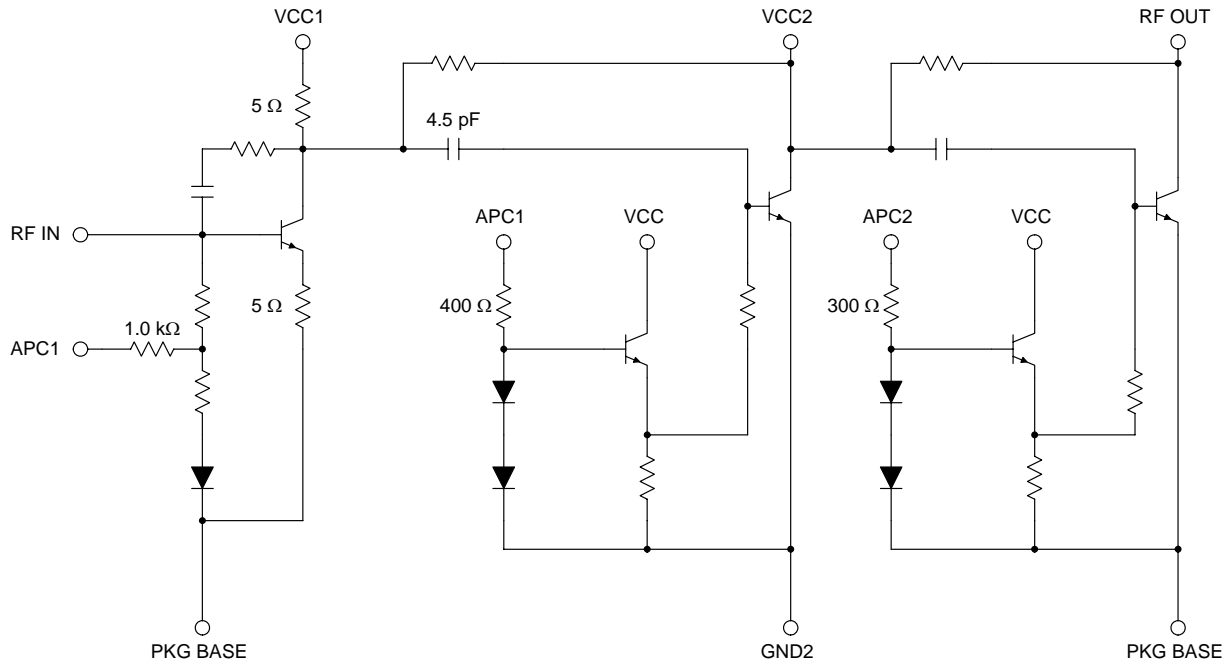

Application Schematic 150MHz FM Band

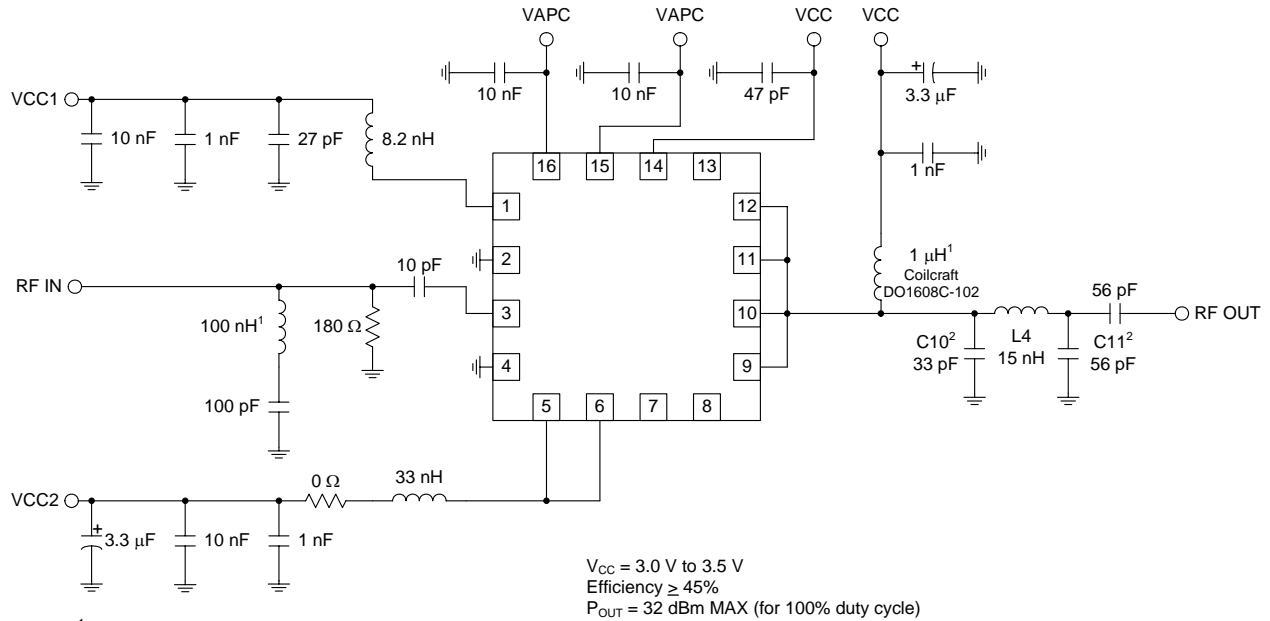

¹Requires layout change to standard evaluation board.
²C10 and C11 adjacent to L4.

Application Schematic 220MHz FM Band

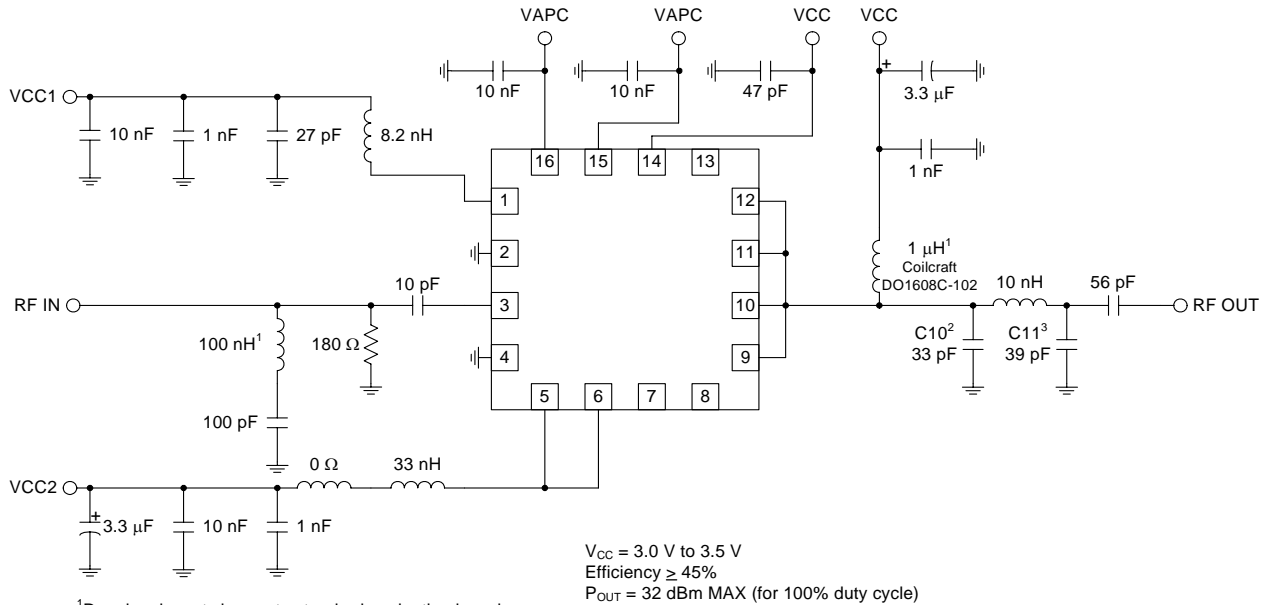

¹Requires layout change to standard evaluation board.
²C10 is adjacent to L4.
³C11 is 140 mils from L4.

RF5110G

Application Schematic 450MHz FM Band

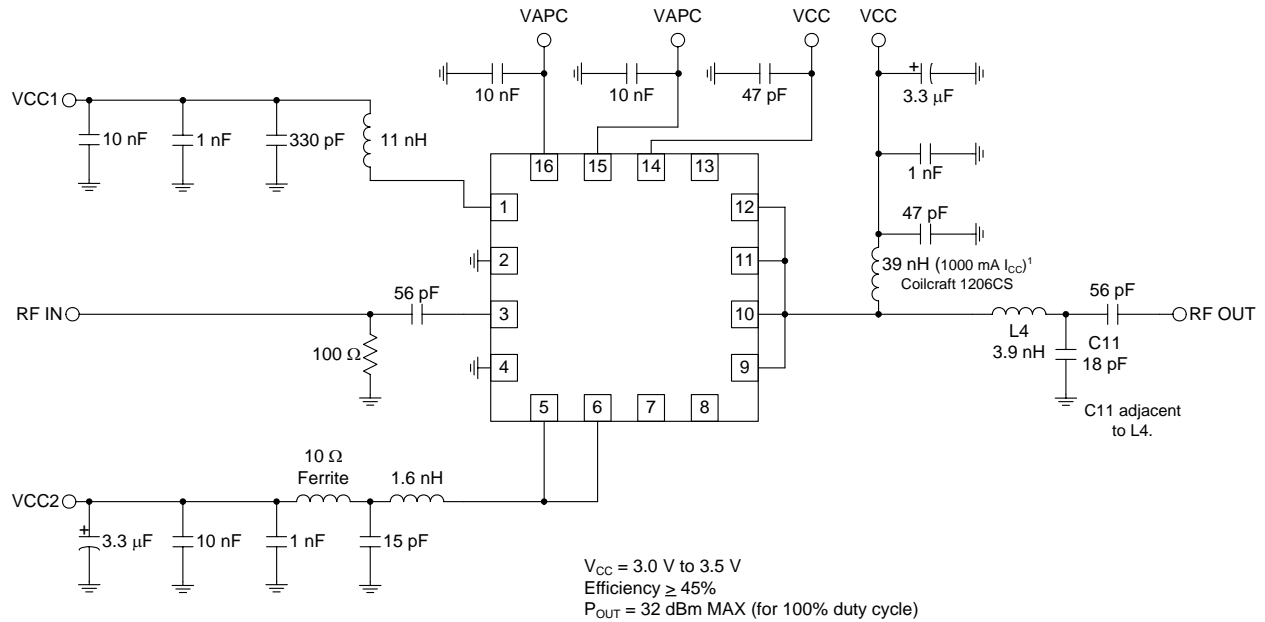

Application Schematic 865MHz and 902MHz - 928MHz ISM Bands

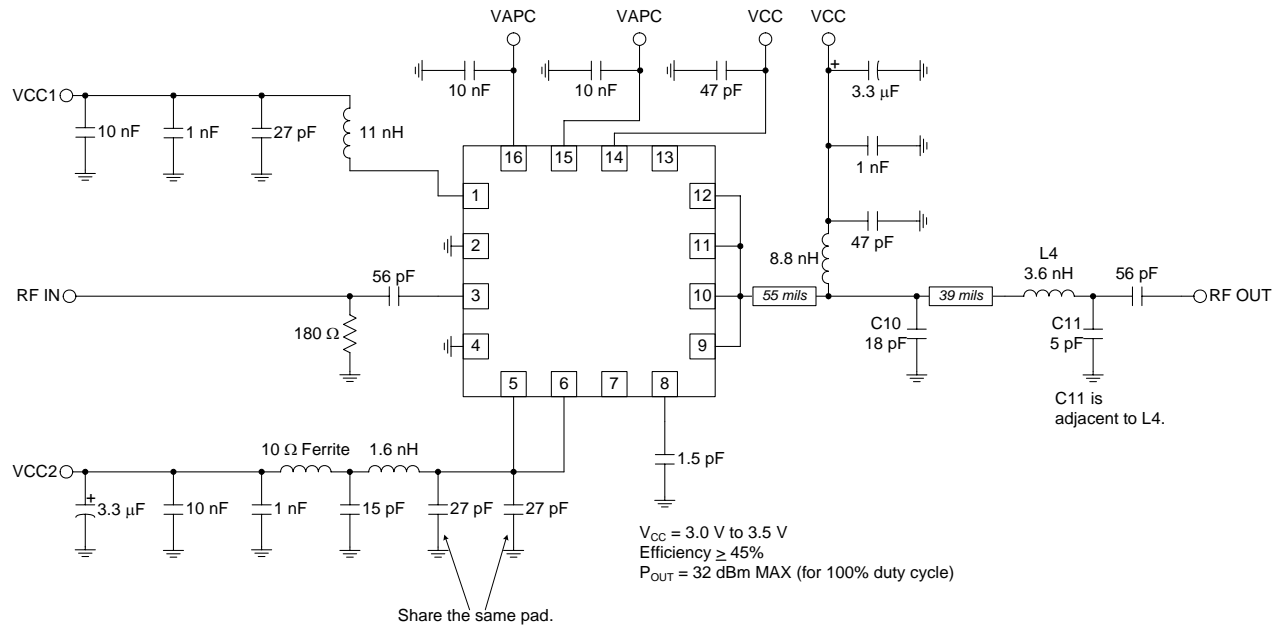

RF5110G

Evaluation Board Schematic GSM850 Lumped Element

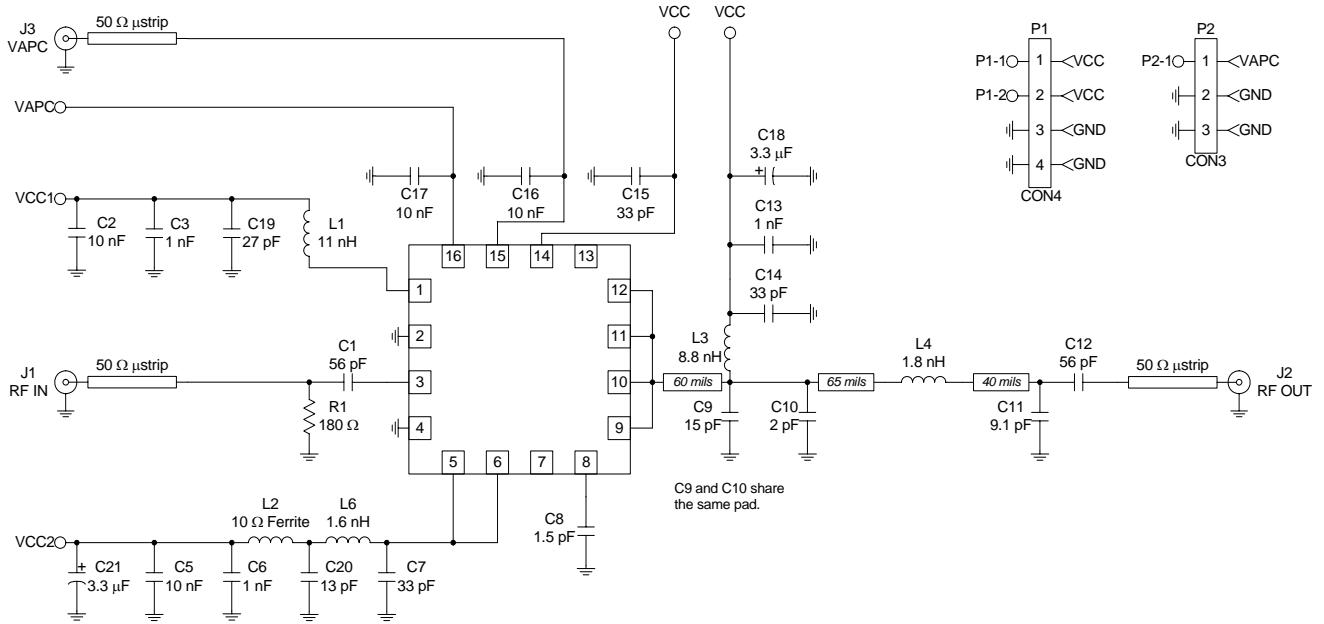

Evaluation Board Schematic GSM900 Lumped Element

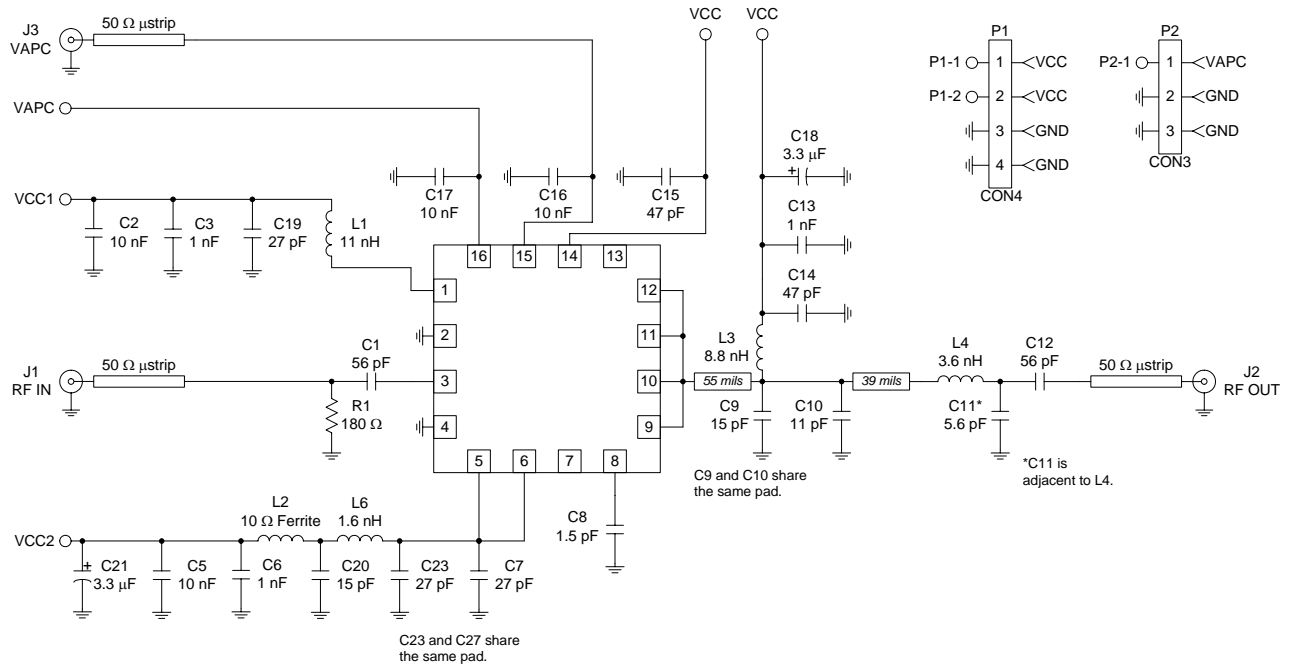

RF5110G

Evaluation Board Layout

Board Size 2.0" x 2.0"

Board Thickness 0.032"; Board Material FR-4; Multi-Layer

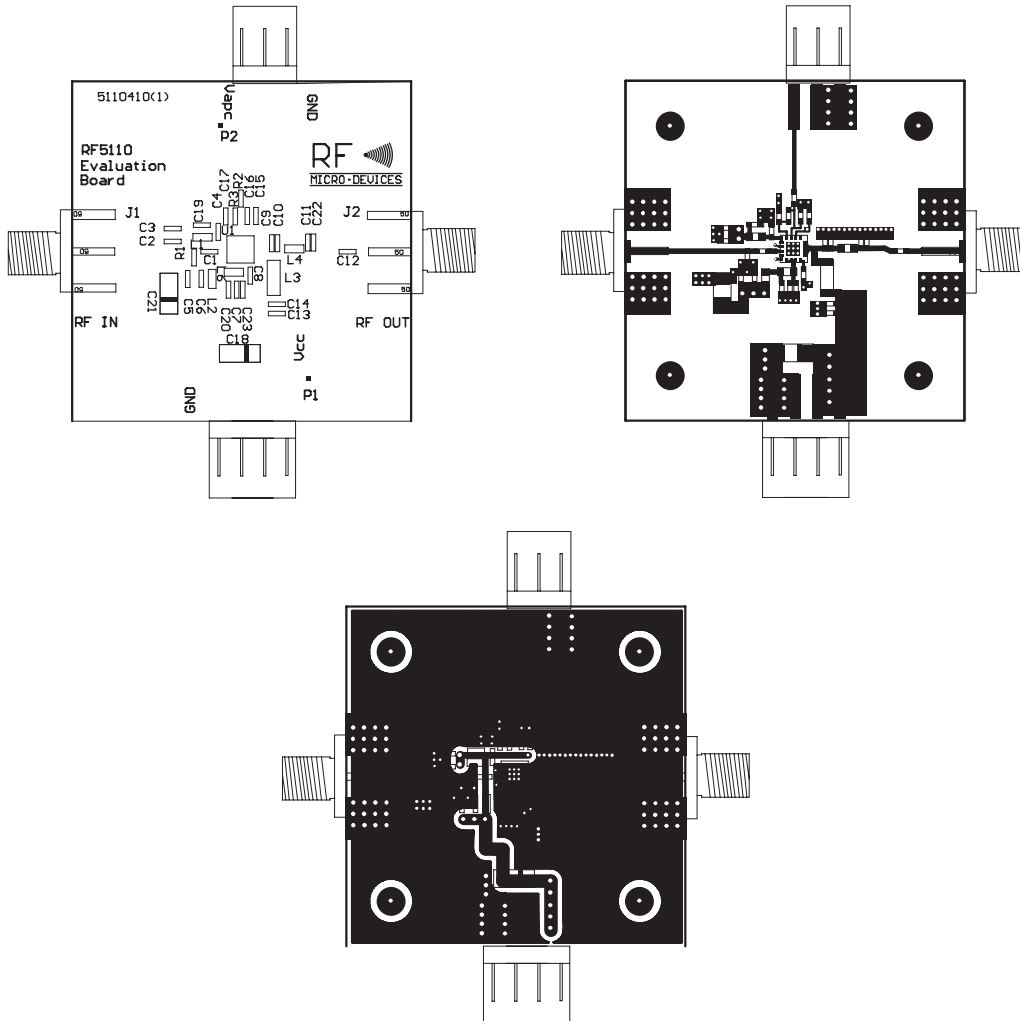

Typical Test Setup

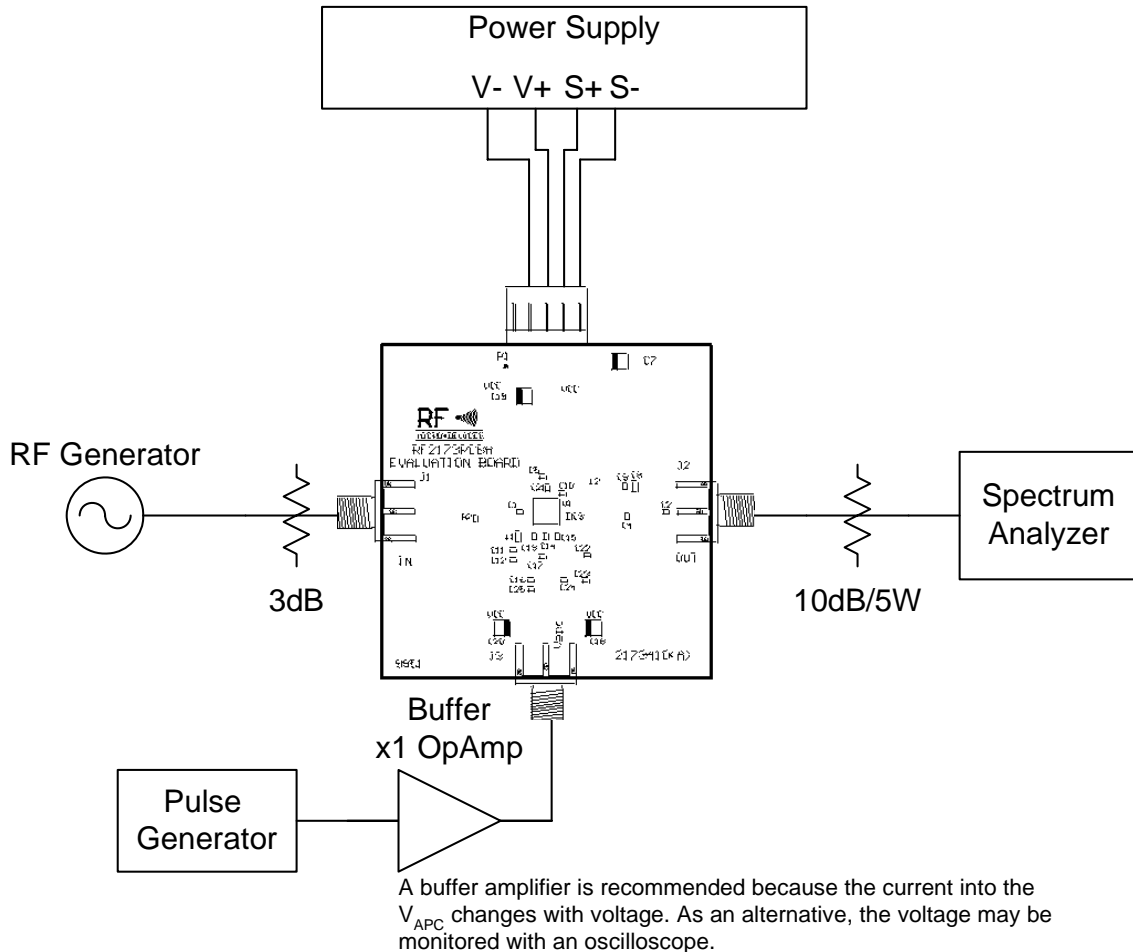

Notes about testing the RF5110G

The test setup shown above includes two attenuators. The 3dB pad at the input is to minimize the effect on the signal generator as a result of switching the input impedance of the PA. When V_{APC} is switched quickly, the resulting input impedance change can cause the signal generator to vary its output signal, either in output level or in frequency. Instead of an attenuator an isolator may also be used. The attenuator at the output is to prevent damage to the spectrum analyzer, and should be sized accordingly to handle the power.

It is important not to exceed the rated supply current and output power. When testing the device at higher than nominal supply voltage, the V_{APC} should be adjusted to avoid the output power exceeding +36dBm. During load-pull testing at the output it is important to monitor the forward power through a directional coupler. The forward power should not exceed +36dBm, and V_{APC} needs to be adjusted accordingly. This simulates the behavior for the power control loop. To avoid damage, it is recommended to set the power supply to limit the current during the burst not to exceed the maximum current rating.

RF5110G

P_{OUT} versus V_{APC} versus Temperature @ 450 MHz

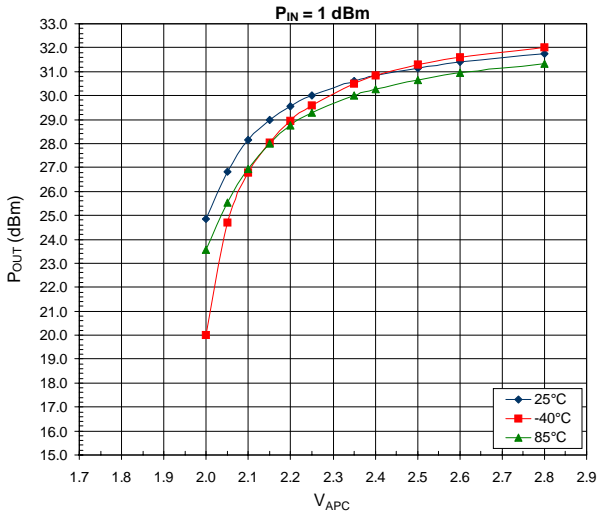

P_{OUT} versus V_{APC} @ 25°C

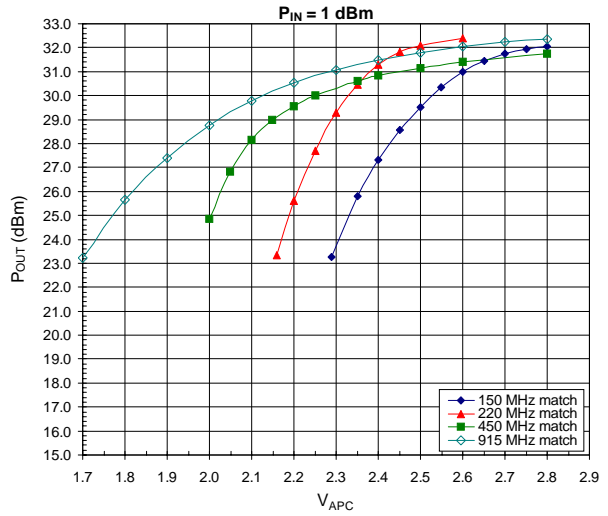

Efficiency versus V_{APC} @ 25°C

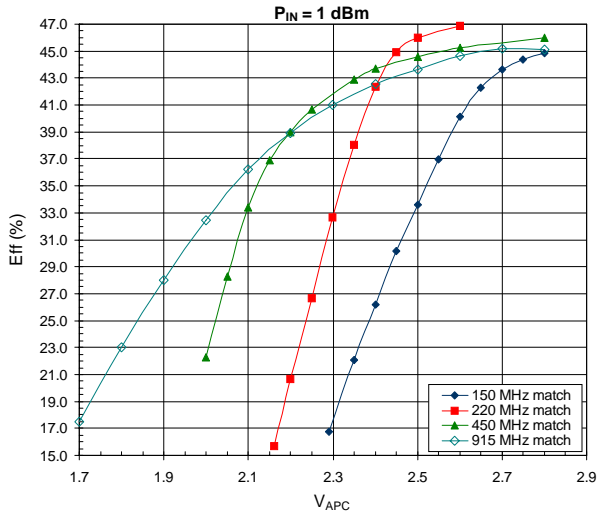

Gain versus V_{APC} @ 25°C

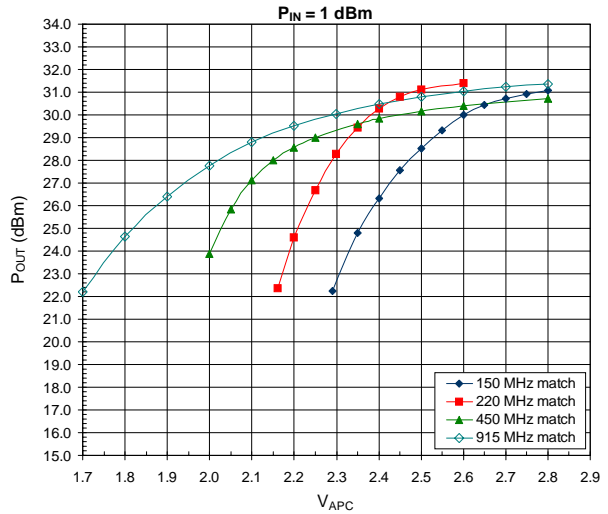

PCB Design Requirements

PCB Surface Finish

The PCB surface finish used for RFMD's qualification process is electroless nickel, immersion gold. Typical thickness is 3μinch to 8μinch gold over 180μinch nickel.

PCB Land Pattern Recommendation

PCB land patterns are based on IPC-SM-782 standards when possible. The pad pattern shown has been developed and tested for optimized assembly at RFMD; however, it may require some modifications to address company specific assembly processes. The PCB land pattern has been developed to accommodate lead and package tolerances.

PCB Metal Land Pattern

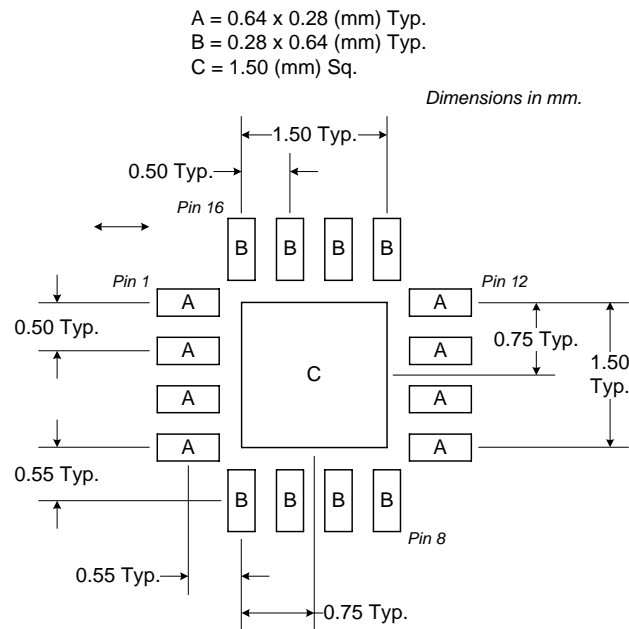

Figure 1. PCB Metal Land Pattern (Top View)

PCB Solder Mask Pattern

Liquid Photo-Imageable (LPI) solder mask is recommended. The solder mask footprint will match what is shown for the PCB metal land pattern with a 2mil to 3mil expansion to accommodate solder mask registration clearance around all pads. The center-grounding pad shall also have a solder mask clearance. Expansion of the pads to create solder mask clearance can be provided in the master data or requested from the PCB fabrication supplier.

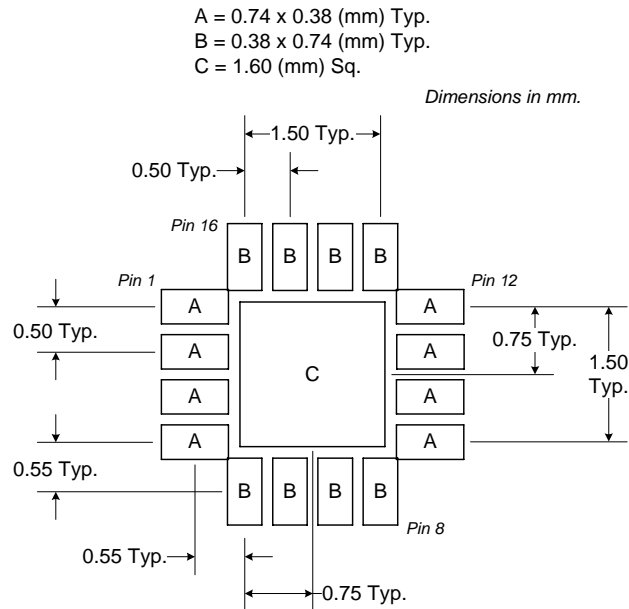

Figure 2. PCB Solder Mask Pattern (Top View)

Thermal Pad and Via Design

The PCB land pattern has been designed with a thermal pad that matches the die paddle size on the bottom of the device.

Thermal vias are required in the PCB layout to effectively conduct heat away from the package. The via pattern has been designed to address thermal, power dissipation and electrical requirements of the device as well as accommodating routing strategies.

The via pattern used for the RFMD qualification is based on thru-hole vias with 0.203mm to 0.330mm finished hole size on a 0.5mm to 1.2mm grid pattern with 0.025mm plating on via walls. If micro vias are used in a design, it is suggested that the quantity of vias be increased by a 4:1 ratio to achieve similar results.

Tape and Reel Information

Carrier tape basic dimensions are based on EIA481. The pocket is designed to hold the part for shipping and loading onto SMT manufacturing equipment, while protecting the body and the solder terminals from damaging stresses. The individual pocket design can vary from vendor to vendor, but width and pitch will be consistent.

Carrier tape is wound or placed onto a shipping reel either 330 mm (13 inches) in diameter or 178 mm (7 inches) in diameter. The center hub design is large enough to ensure the radius formed by the carrier tape around it does not put unnecessary stress on the parts.

Prior to shipping, moisture sensitive parts (MSL level 2a-5a) are baked and placed into the pockets of the carrier tape. A cover tape is sealed over the top of the entire length of the carrier tape. The reel is sealed in a moisture barrier, ESD bag, which is placed in a cardboard shipping box. It is important to note that unused moisture sensitive parts need to be resealed in the moisture barrier bag. If the reels exceed the exposure limit and need to be rebaked, most carrier tape and shipping reels are not rated as bakeable at 125°C. If baking is required, devices may be baked according to section 4, table 4-1, column 8 of Joint Industry Standard IPC/JEDEC J-STD-033A.

The following table provides useful information for carrier tape and reels used for shipping the devices described in this document.

RFMD Part Number	Reel Diameter Inch (mm)	Hub Diameter Inch (mm)	Width (mm)	Pocket Pitch (mm)	Feed	Units per Reel
RF5110GTR7	7 (178)	2.4 (61)	12	4	Single	2500

QFN (Carrier Tape Drawing with Part Orientation)

Notes:

1. All dimensions are in millimeters (mm).
2. Unless otherwise specified, all dimension tolerances per EIA-481.

$A_o = 3.18 \pm 0.10$
 $B_o = 3.18 \pm 0.10$
 $F = 5.50 \pm 0.05$
 $K_o = 1.02 \pm 0.10$
 $P = 4.00 \pm 0.10$
 $W = 12.00 +0.30/-0.10$

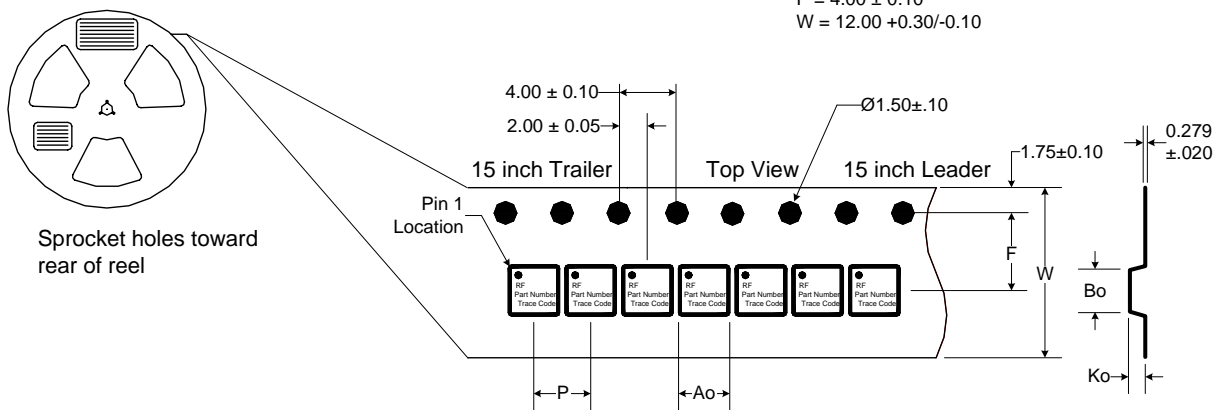

RF5110G