

STRUCTURE Silicon monolithic integrated circuits

PRODUCT SERIES 3-phase spindle motor driver

TYPE **BA6664FM**

FUNCTION • 3-phase, full-wave pseudo linear driving system
 • Suitable for 3.3V DSP

○Absolute maximum ratings (Ta=25°C)

Parameter	Symbol	Limit	Unit
Supply voltage	VCC	7	V
	VM	15	V
Power dissipation	Pd	2200 ^{*1}	mW
Input voltage	VIN	0~VCC	V
Output current	IOUT	1300 ^{*2}	mA
Operating temperature range	Topr	-40~+85	°C
Storage temperature range	Tstg	-55~+150	°C
Junction temperature	Tjmax	150	°C

*1 70mm × 70mm × 1.6mm glass epoxy board. Derating is done at 17.6mW/°C for operating above Ta=25°C.

*2 Do not, however exceed Pd, ASO and Tjmax=150°C.

○Operating conditions (Ta= -40~+85°C)

Parameter	Symbol	Min	Typ	Max	Unit
Supply voltage	VCC	4.5	5	5.5	V
	VM	3	12	14	V
Output current	IOUT	-	-	1000 ^{*2}	mA

This product isn't designed for protection against radioactive rays.

Status of this document

The Japanese version of this document is the formal specification.

A customer may use this translation version only for a reference to help reading the formal version.

If there are any differences in translation version of this document, formal version takes priority.

○Electrical characteristics (Unless otherwise specified, Ta=25°C, VCC=5.0V, VM=12V)

Parameter	Symbol	Limit			Unit	Conditions
		Min	Typ	Max		
Overall						
Circuit current 1	I _{CC1}	–	0	0.2	mA	PS=L, GSW=OPEN
Circuit current 2	I _{CC2}	–	6.2	9.1	mA	PS=H, GSW=OPEN
Power save						
ON voltage range	V _{PSON}	–	–	1.0	V	Circuit OFF
OFF voltage range	V _{PSOFF}	2.5	–	–	V	Circuit ON
Hall Bias						
Hall bias voltage	V _{HB}	0.5	0.9	1.5	V	I _{HB} =10mA
Hall amp						
Input bias current	I _{HA}	–	0.7	3.0	μA	
In-phase input voltage range	V _{HAR}	1.0	–	4.0	V	
Minimum input level	V _{INH}	50	–	–	mVpp	
H3 hysteresis level	V _{HYS}	5	20	40	mV	
Torque control						
Input voltage range	E _C , E _{CR}	0	–	VCC	V	(Linear range 0.5V~3.3V)
Offset voltage -	E _{COFF-}	-75	-45	-15	mV	E _{CR} =1.65V, GSW=L
Offset voltage +	E _{COFF+}	15	45	75	mV	E _{CR} =1.65V, GSW=L
Input bias current	E _{CIN}	-3	–	3	μA	E _C =E _{CR}
Input-output gain L	G _{ECL}	0.52	0.65	0.78	A/V	GSW=L, RNF=0.5Ω
Input-output gain M	G _{ECM}	1.04	1.3	1.56	A/V	GSW=OPEN, RNF=0.5Ω
Input-output gain H	G _{ECH}	2.24	2.8	3.36	A/V	GSW=H, RNF=0.5Ω
FG						
FG output HI voltage	V _{FGH}	4.5	4.8	–	V	I _{FG} =-20 μA
FG output LOW voltage	V _{FGL}	–	0.2	0.4	V	I _{FG} =3.0mA
FG2						
FG output HI voltage	V _{FG2H}	4.6	4.9	–	V	I _{FG2} =-20 μA
FG output LOW voltage	V _{FG2L}	–	0.2	0.4	V	I _{FG2} =3.0mA
Rotation detect						
FR output voltage H	V _{FRH}	4.1	4.4	–	V	I _{FR} =-20 μA
FR output voltage L	V _{FRL}	–	0.2	0.4	V	I _{FR} =3.0mA
Output						
Saturation voltage H	V _{OH}	–	1.0	1.35	V	I _{OUT} =-600mA
Saturation voltage L	V _{OL}	–	0.4	0.65	V	I _{OUT} =600mA
Pre-drive current	I _{VML}	–	35	70	mA	E _C =0V, Output open
Torque limit current	I _{TL}	560	700	840	mA	RNF=0.5Ω
Short brake						
ON voltage range	V _{SBON}	2.5	–	–	V	BR=0V
OFF voltage range	V _{SBOFF}	–	–	1.0	V	BR=0V
Brake mode						
ON voltage range	V _{BRON}	2.5	–	–	V	E _C >E _{CR} , SB=OPEN
OFF voltage range	V _{BROFF}	–	–	1.0	V	E _C >E _{CR} , SB=OPEN
Gain switch						
LOW voltage range	V _{GSWL}	–	–	1.0	V	
HI voltage range	V _{GSWH}	3.0	–	–	V	
OPEN voltage	V _{GSWOP}	–	2.0	–	V	

○Package outline

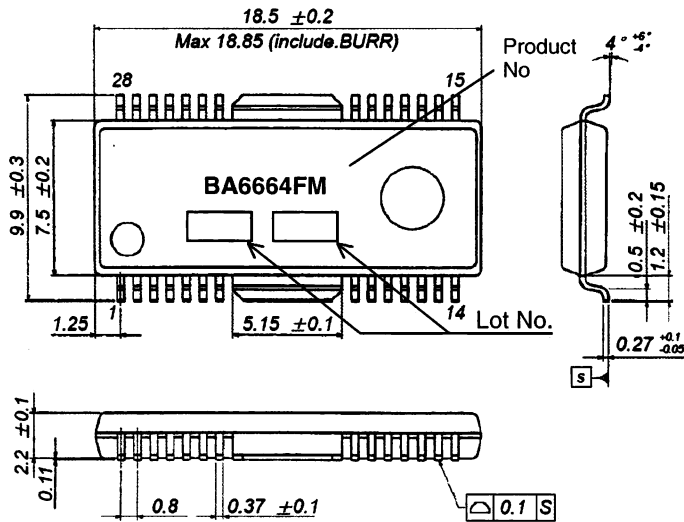

HSOP-M28 (Unit:mm)

○Block diagram

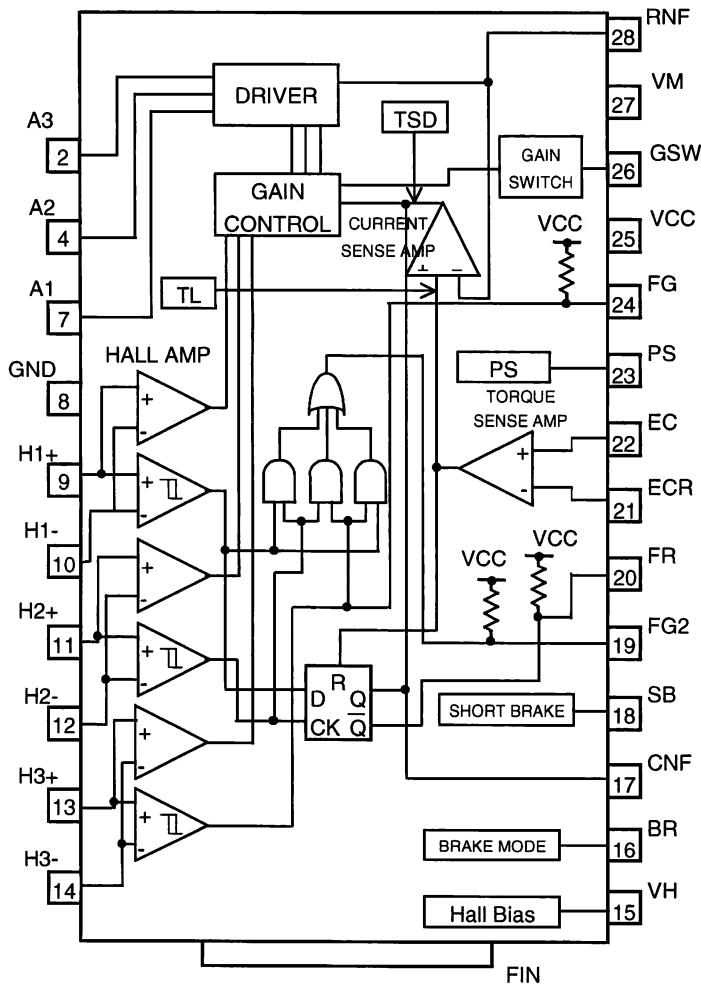

○Pin No. / Pin name

Pin No.	Pin name	Pin No.	Pin name
1	N.C.	15	VH
2	A3	16	BR
3	N.C.	17	CNF
4	A2	18	SB
5	N.C.	19	FG2
6	N.C.	20	FR
7	A1	21	ECR
8	GND	22	EC
9	H1+	23	PS
10	H1-	24	FG
11	H2+	25	VCC
12	H2-	26	GSW
13	H3+	27	VM
14	H3-	28	RNF
		FIN	FIN

* FIN : GND

○Operation Notes

(1) Absolute maximum ratings

Use of the IC in excess of absolute maximum ratings such as the applied voltage or operating temperature range (Topr) may result in IC damage. Assumptions should not be made regarding the state of the IC (short mode or open mode) when such damage is suffered. The implementation of a physical safety measure such as a fuse should be considered when use of the IC in a special mode where the absolute maximum ratings may be exceeded is anticipated.

(2) Power supply lines

Regenerated current may flow as a result of the motor's back electromotive force. Insert capacitors between the power supply and ground pins to serve as a route for regenerated current. Determine the capacitance in full consideration of all the characteristics of the electrolytic capacitor, because the electrolytic capacitor may lose some capacitance at low temperatures. If the connected power supply does not have sufficient current absorption capacity, regenerative current will cause the voltage on the power supply line to rise, which combined with the product and its peripheral circuitry may exceed the absolute maximum ratings. It is recommended to implement a physical safety measure such as the insertion of a voltage clamp diode between the power supply and GND pins.

(3) Ground potential

Ensure a minimum GND pin potential in all operating conditions.

(4) Setting of heat

Use a thermal design that allows for a sufficient margin in light of the power dissipation (Pd) in actual operating conditions.

(5) Actions in strong magnetic field

Use caution when using the IC in the presence of a strong magnetic field as doing so may cause the IC to malfunction.

(6) ASO

When using the IC, set the output transistor for the motor so that it does not exceed absolute maximum ratings or ASO.

(7) Thermal shutdown circuit

This IC incorporates a TSD (thermal shutdown) circuit. If the temperature of the chip reaches the following temperature, the motor coil output will be opened. The thermal shutdown circuit (TSD circuit) is designed only to shut the IC off to prevent runaway thermal operation. It is not designed to protect the IC or guarantee its operation. Do not continue to use the IC after operating this circuit or use the IC in an environment where the operation of this circuit is assumed.

TSD on temperature [°C] (typ.)	Hysteresis temperature [°C] (typ.)
175	15

(8) Ground Wiring Pattern

When using both small signal and large current GND patterns, it is recommended to isolate the two ground patterns, placing a single ground point at the application's reference point so that the pattern wiring resistance and voltage variations caused by large currents do not cause variations in the small signal ground voltage. Be careful not to change the GND wiring pattern of any external components, either.

Notes

- No technical content pages of this document may be reproduced in any form or transmitted by any means without prior permission of ROHM CO.,LTD.
- The contents described herein are subject to change without notice. The specifications for the product described in this document are for reference only. Upon actual use, therefore, please request that specifications to be separately delivered.
- Application circuit diagrams and circuit constants contained herein are shown as examples of standard use and operation. Please pay careful attention to the peripheral conditions when designing circuits and deciding upon circuit constants in the set.
- Any data, including, but not limited to application circuit diagrams information, described herein are intended only as illustrations of such devices and not as the specifications for such devices. ROHM CO.,LTD. disclaims any warranty that any use of such devices shall be free from infringement of any third party's intellectual property rights or other proprietary rights, and further, assumes no liability of whatsoever nature in the event of any such infringement, or arising from or connected with or related to the use of such devices.
- Upon the sale of any such devices, other than for buyer's right to use such devices itself, resell or otherwise dispose of the same, no express or implied right or license to practice or commercially exploit any intellectual property rights or other proprietary rights owned or controlled by
- ROHM CO., LTD. is granted to any such buyer.
- Products listed in this document are no antiradiation design.

The products listed in this document are designed to be used with ordinary electronic equipment or devices (such as audio visual equipment, office-automation equipment, communications devices, electrical appliances and electronic toys).

Should you intend to use these products with equipment or devices which require an extremely high level of reliability and the malfunction of which would directly endanger human life (such as medical instruments, transportation equipment, aerospace machinery, nuclear-reactor controllers, fuel controllers and other safety devices), please be sure to consult with our sales representative in advance.

About Export Control Order in Japan

Products described herein are the objects of controlled goods in Annex 1 (Item 16) of Export Trade Control Order in Japan.

In case of export from Japan, please confirm if it applies to "objective" criteria or an "informed" (by MITI clause) on the basis of "catch all controls for Non-Proliferation of Weapons of Mass Destruction.

Thank you for your accessing to ROHM product informations.
More detail product informations and catalogs are available,
please contact your nearest sales office.

Please contact our sales offices for details ;

U.S.A / San Diego	TEL : +1(858)625-3630	FAX : +1(858)625-3670
Atlanta	TEL : +1(770)754-5972	FAX : +1(770)754-0691
Dallas	TEL : +1(972)312-8818	FAX : +1(972)312-0330
Germany / Dusseldorf	TEL : +49(2154)9210	FAX : +49(2154)921400
United Kingdom / London	TEL : +44(1)908-282-666	FAX : +44(1)908-282-528
France / Paris	TEL : +33(0)1 56 97 30 60	FAX : +33(0) 1 56 97 30 80
China / Hong Kong	TEL : +852(2)740-6262	FAX : +852(2)375-8971
Shanghai	TEL : +86(21)6279-2727	FAX : +86(21)6247-2066
Dilian	TEL : +86(411)8230-8549	FAX : +86(411)8230-8537
Beijing	TEL : +86(10)8525-2483	FAX : +86(10)8525-2489
Taiwan / Taipei	TEL : +866(2)2500-6956	FAX : +866(2)2503-2869
Korea / Seoul	TEL : +82(2)8182-700	FAX : +82(2)8182-715
Singapore	TEL : +65-6332-2322	FAX : +65-6332-5662
Malaysia / Kuala Lumpur	TEL : +60(3)7958-8355	FAX : +60(3)7958-8377
Philippines / Manila	TEL : +63(2)807-6872	FAX : +63(2)809-1422
Thailand / Bangkok	TEL : +66(2)254-4890	FAX : +66(2)256-6334

Japan /
(Internal Sales)

Tokyo	2-1-1, Yaesu, Chuo-ku, Tokyo 104-0082	TEL : +81(3)5203-0321	FAX : +81(3)5203-0300
Yokohama	2-4-8, Shin Yokohama, Kohoku-ku, Yokohama, Kanagawa 222-8575	TEL : +81(45)476-2131	FAX : +81(45)476-2128
Nagoya	Dainagayo Building 9F 3-28-12, Meieki, Nakamura-ku, Nagoya, Aichi 450-0002	TEL : +81(52)581-8521	FAX : +81(52)561-2173
Kyoto	579-32 Higashi Shiokouji-cho, Karasuma Nishi-iru, Shiokoujidori, Shimogyo-ku, Kyoto 600-8216	TEL : +81(75)311-2121	FAX : +81(75)314-6559

(Contact address for overseas customers in Japan)

Yokohama	TEL : +81(45)476-9270	FAX : +81(045)476-9271
----------	-----------------------	------------------------