

UTC2SD1664 NPN EPITAXIAL SILICON TRANSISTOR

MEDIUM POWER NPN TRANSISTOR

DESCRIPTION

The UTC 2SD1664 is an epitaxial planar type NPN silicon transistor.

FEATURES

*Low $V_{CE(sat)}$: $V_{CE(sat)} = 0.15V$ (Typ)
($I_C/I_B = 500mA/50mA$)

*Complement the 2SB1132.

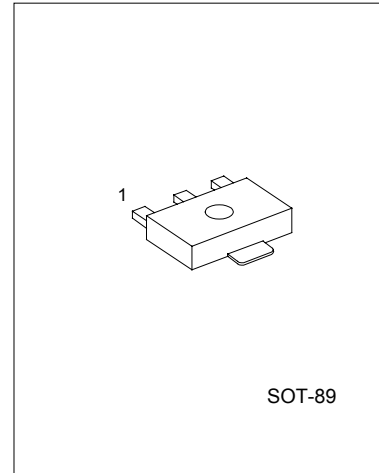

1:EMITTER 2:COLLECTOR 3:BASE

ABSOLUTE MAXIMUM RATINGS ($T_a=25^{\circ}C$)

PARAMETER	SYMBOL	RATING	UNIT
Collector-Base Voltage	V_{CB0}	40	V
Collector-Emitter Voltage	V_{CEO}	32	V
Emitter-Base Voltage	V_{EB0}	5	V
Collector Current DC PULSE (Note1)	I_C	1	A
		2	A
Collector Power Dissipation	P_C	0.5	W
		2 (Note2)	W
Junction Temperature	T_j	150	$^{\circ}C$
Storage Temperature	T_{STG}	-55 ~ +150	$^{\circ}C$

Note1: Duty=1/2, $P_w=20ms$

Note2: When mounted on a 40*40*0.7 mm ceramic board.

ELECTRICAL CHARACTERISTICS ($T_a=25^{\circ}C$, unless otherwise specified)

PARAMETER	SYMBOL	TEST CONDITIONS	MIN	TYP	MAX	UNIT
Collector Base Breakdown Voltage	BV_{CB0}	$I_C = 50 \mu A$	40			V
Collector Emitter Breakdown Voltage	BV_{CEO}	$I_C = 1mA$	32			V
Emitter Base Breakdown Voltage	BV_{EB0}	$I_E = 50 \mu A$	5			V
Collector Cut-Off Current	I_{CBO}	$V_{CB} = 20V$			0.5	μA
Emitter Cut-Off Current	I_{EBO}	$V_{EB} = 4V$			0.5	μA
DC Current Transfer Ratio	h_{FE}	$V_{CE} = 3V, I_C = 100mA$	82		390	
Collector-Emitter Saturation Voltage	$V_{CE(sat)}$	$I_C/I_B = 500mA/50mA$		0.15	0.4	V
Transition Frequency	f_T	$V_{CE} = 5V, I_E = -50mA, f = 100MHz$		150		MHz
Output Capacitance	C_{ob}	$V_{CB} = 10V, I_E = 0A, f = 1MHz$		15		pF

CLASSIFICATION OF h_{FE}

RANK	P	Q	R
RANGE	82-180	120-270	180-390

UTC UNISONIC TECHNOLOGIES CO. LTD

1

QW-R208-025,A

ELECTRICAL CHARACTERISTICS CURVES

Figure 1. Grounded Emitter Propagation Characteristics

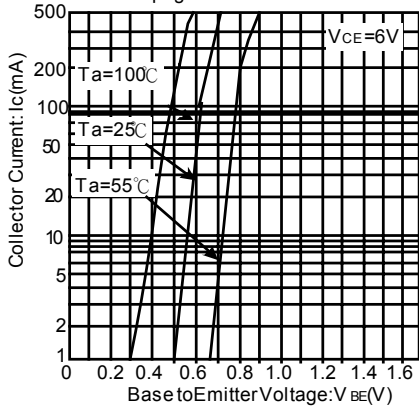

Figure 2. Grounded Emitter Output Characteristics

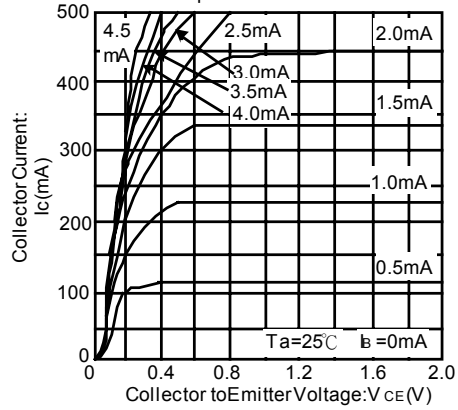

Figure 3. DC Current Gain vs. Collector Current (I)

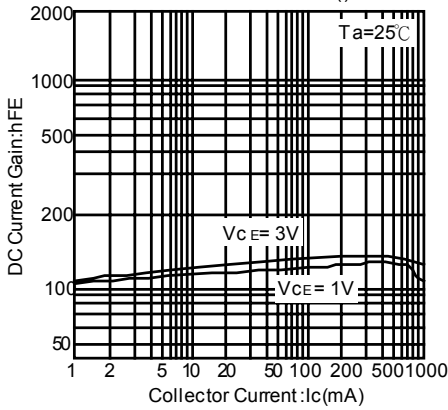

Figure 4. DC Current Gain vs. Collector Current (II)

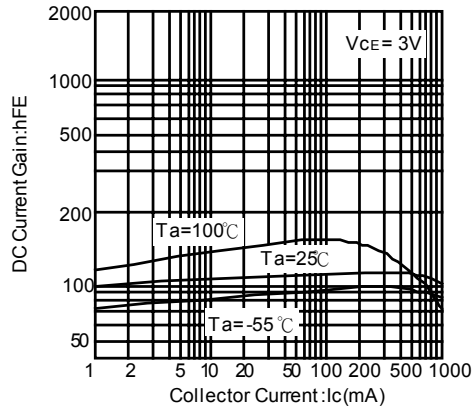

Figure 5. Collector-emitter Saturation Voltage vs. Collector Current (I)

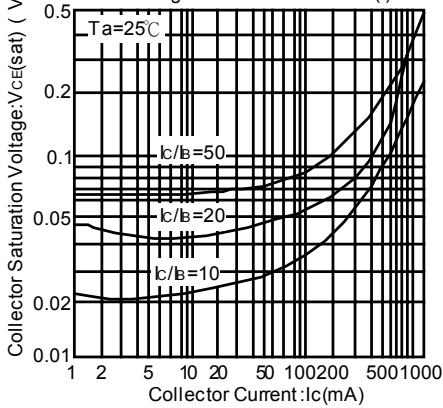

Figure 6. Collector-emitter Saturation Voltage vs. Collector Current (II)

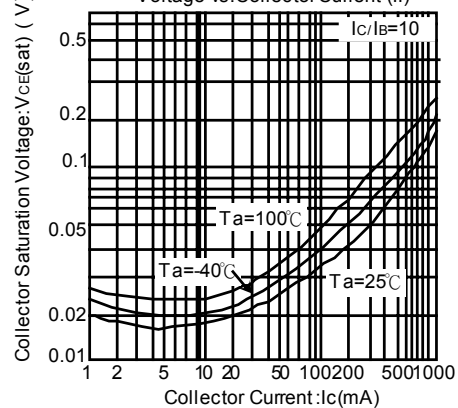

Figure 7. Gain Bandwidth Product vs. Emitter Current

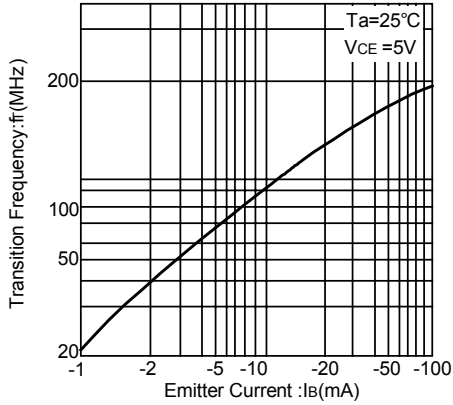

Figure 8. Collector Output Capacitance vs. Collector-base Voltage

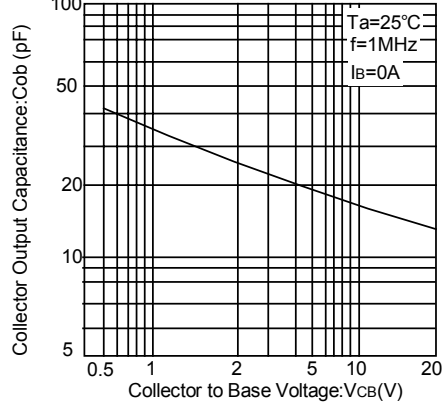

Figure 9. Safe Operation Area

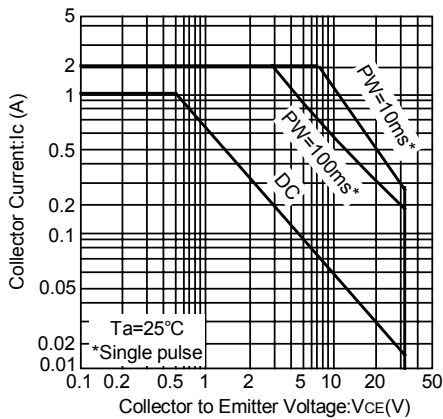
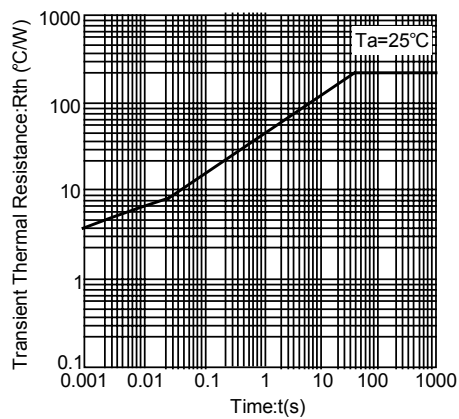

Figure 10. Transient Thermal Resistance



UTC assumes no responsibility for equipment failures that result from using products at values that exceed, even momentarily, rated values (such as maximum ratings, operating condition ranges, or other parameters) listed in products specifications of any and all UTC products described or contained herein. UTC products are not designed for use in life support appliances, devices or systems where malfunction of these products can be reasonably expected to result in personal injury. Reproduction in whole or in part is prohibited without the prior written consent of the copyright owner. The information presented in this document does not form part of any quotation or contract, is believed to be accurate and reliable and may be changed without notice.