

# HITACHI

KAOHSIUNG HITACHI  
ELECTRONICS CO.,LTD  
P.O. BOX 26-27  
2,13TH EAST ST. K.E.P.Z.  
KAOHSIUNG TAIWAN R.O.C.  
TEL:(07) 821-5811(7 LINE)  
FAX:(07) 821-5815

MSC Vertriebs-GmbH  
Productmarketing  
Displays & Systems  
Friedrich-Bergius-Str. 9  
D - 65203 Wiesbaden  
Tel:+49-611-97320-0  
Fax:+49-61197320-88  
<http://www.msc-ge.com>

FOR MESSRS: \_\_\_\_\_

DATE : Nov.28,2003

## CUSTOMER'S ACCEPTANCE SPECIFICATIONS

### TX14D11VM1CAA

#### CONTENTS

| No. | ITEM                       | SHEET No.                   | PAGE        |
|-----|----------------------------|-----------------------------|-------------|
| 1   | COVER                      | 7B64PS 2701-TX14D11VM1CAA-2 | 1-1/1       |
| 2   | RECORD OF REVISION         | 7B64PS 2702-TX14D11VM1CAA-2 | 2-1/1       |
| 3   | GENERAL DATA               | 7B64PS 2703-TX14D11VM1CAA-2 | 3-1/1       |
| 4   | ABSOLUTE MAXIMUM RATINGS   | 7B64PS 2704-TX14D11VM1CAA-2 | 4-1/1       |
| 5   | ELECTRICAL CHARACTERISTICS | 7B64PS 2705-TX14D11VM1CAA-2 | 5-1/3~3/3   |
| 6   | OPTICAL CHARACTERISTICS    | 7B64PS 2706-TX14D11VM1CAA-2 | 6-1/3~3/3   |
| 7   | BLOCK DIAGRAM              | 7B64PS 2707-TX14D11VM1CAA-2 | 7-1/1       |
| 8   | INTERFACE TIMING CHART     | 7B64PS 2708-TX14D11VM1CAA-2 | 8-1/5~5/5   |
| 9   | DIMENSIONAL OUTLINE        | 7B63PS 2709-TX14D11VM1CAA-2 | 9-1/2~9-2/2 |
| 10  | APPEARANCE STANDARD        | 7B64PS 2710-TX14D11VM1CAA-2 | 10-1/5~5/5  |
| 11  | PRECAUTION IN DESIGN       | 7B64PS 2711-TX14D11VM1CAA-2 | 11-1/3~3/3  |
| 12  | DESIGNATION OF LOT MARK    | 7B64PS 2712-TX14D11VM1CAA-2 | 12-1/1      |
| 13  | PRECAUTION FOR USE         | 7B64PS 2713-TX14D11VM1CAA-2 | 13-1/1      |

\*When product will be discontinued, customer will be informed by HITACHI with twelve months prior announcement.

ACCEPTED BY: \_\_\_\_\_

PROPOSED BY: *H. Ogawa*

|   |            |                             |      |       |
|---|------------|-----------------------------|------|-------|
| KAOHSIUNG HITACHI<br>ELECTRONICS CO.,LTD. | Sh.<br>No. | 7B64PS 2701-TX14D11VM1CAA-2 | PAGE | 1-1/1 |
|---|------------|-----------------------------|------|-------|

## RECORD OF REVISION

| DATE   | SHEET No.   | SUMMARY  |                            |        |           |      |              |            |                            |      |            |                              |      |            |                             |      |            |                              |      |      |        |           |      |              |            |                            |    |            |                              |    |            |                             |    |            |                              |    |
|--|---|--|----------------------------|--------|-----------|------|--------------|------------|----------------------------|------|------------|------------------------------|------|------------|-----------------------------|------|------------|------------------------------|------|------|--------|-----------|------|--------------|------------|----------------------------|----|------------|------------------------------|----|------------|-----------------------------|----|------------|------------------------------|----|
| Nov.28,'03                                   | 7B64PS2703-<br>TX14D11VM1CAA-2<br>PAGE 3-1/1                                  | 3. GENERAL DATA<br>ADDED : (14) View Direction 6 O'clock   |                            |        |           |      |              |            |                            |      |            |                              |      |            |                             |      |            |                              |      |      |        |           |      |              |            |                            |    |            |                              |    |            |                             |    |            |                              |    |
|  | 7B64PS2706-<br>TX14D11VM1CAA-2<br>PAGE 6-1/3                                  | 6.1 OPTICAL CHARACTERISTICS OF LCD<br><br><table border="1" style="width: 100%; border-collapse: collapse; margin-bottom: 10px;"> <thead> <tr> <th style="width: 20%;">ITEM</th> <th style="width: 20%;">SYMBOL</th> <th style="width: 40%;">CONDITION</th> <th style="width: 20%;">TYP.</th> </tr> </thead> <tbody> <tr> <td rowspan="4" style="text-align: center; vertical-align: middle;">Viewing Area</td> <td style="text-align: center;"><math>\theta x</math></td> <td style="text-align: center;"><math>\phi=0^\circ, K \geq 5.0</math></td> <td style="text-align: center;">(50)</td> </tr> <tr> <td style="text-align: center;"><math>\theta x</math></td> <td style="text-align: center;"><math>\phi=180^\circ, K \geq 5.0</math></td> <td style="text-align: center;">(50)</td> </tr> <tr> <td style="text-align: center;"><math>\theta y</math></td> <td style="text-align: center;"><math>\phi=90^\circ, K \geq 5.0</math></td> <td style="text-align: center;">(40)</td> </tr> <tr> <td style="text-align: center;"><math>\theta y</math></td> <td style="text-align: center;"><math>\phi=270^\circ, K \geq 5.0</math></td> <td style="text-align: center;">(80)</td> </tr> </tbody> </table> <div style="text-align: center; margin-bottom: 10px;">↓</div> <table border="1" style="width: 100%; border-collapse: collapse;"> <thead> <tr> <th style="width: 20%;">ITEM</th> <th style="width: 20%;">SYMBOL</th> <th style="width: 40%;">CONDITION</th> <th style="width: 20%;">TYP.</th> </tr> </thead> <tbody> <tr> <td rowspan="4" style="text-align: center; vertical-align: middle;">Viewing Area</td> <td style="text-align: center;"><math>\theta x</math></td> <td style="text-align: center;"><math>\phi=0^\circ, K \geq 5.0</math></td> <td style="text-align: center;">65</td> </tr> <tr> <td style="text-align: center;"><math>\theta x</math></td> <td style="text-align: center;"><math>\phi=180^\circ, K \geq 5.0</math></td> <td style="text-align: center;">65</td> </tr> <tr> <td style="text-align: center;"><math>\theta y</math></td> <td style="text-align: center;"><math>\phi=90^\circ, K \geq 5.0</math></td> <td style="text-align: center;">70</td> </tr> <tr> <td style="text-align: center;"><math>\theta y</math></td> <td style="text-align: center;"><math>\phi=270^\circ, K \geq 5.0</math></td> <td style="text-align: center;">50</td> </tr> </tbody> </table> | ITEM                       | SYMBOL | CONDITION | TYP. | Viewing Area | $\theta x$ | $\phi=0^\circ, K \geq 5.0$ | (50) | $\theta x$ | $\phi=180^\circ, K \geq 5.0$ | (50) | $\theta y$ | $\phi=90^\circ, K \geq 5.0$ | (40) | $\theta y$ | $\phi=270^\circ, K \geq 5.0$ | (80) | ITEM | SYMBOL | CONDITION | TYP. | Viewing Area | $\theta x$ | $\phi=0^\circ, K \geq 5.0$ | 65 | $\theta x$ | $\phi=180^\circ, K \geq 5.0$ | 65 | $\theta y$ | $\phi=90^\circ, K \geq 5.0$ | 70 | $\theta y$ | $\phi=270^\circ, K \geq 5.0$ | 50 |
|  | ITEM  | SYMBOL   | CONDITION                  | TYP.   |           |      |              |            |                            |      |            |                              |      |            |                             |      |            |                              |      |      |        |           |      |              |            |                            |    |            |                              |    |            |                             |    |            |                              |    |
|  | Viewing Area  | $\theta x$   | $\phi=0^\circ, K \geq 5.0$ | (50)   |           |      |              |            |                            |      |            |                              |      |            |                             |      |            |                              |      |      |        |           |      |              |            |                            |    |            |                              |    |            |                             |    |            |                              |    |
| $\theta x$                                   |   | $\phi=180^\circ, K \geq 5.0$   | (50)                       |        |           |      |              |            |                            |      |            |                              |      |            |                             |      |            |                              |      |      |        |           |      |              |            |                            |    |            |                              |    |            |                             |    |            |                              |    |
| $\theta y$                                   |   | $\phi=90^\circ, K \geq 5.0$  | (40)                       |        |           |      |              |            |                            |      |            |                              |      |            |                             |      |            |                              |      |      |        |           |      |              |            |                            |    |            |                              |    |            |                             |    |            |                              |    |
| $\theta y$                                   |   | $\phi=270^\circ, K \geq 5.0$   | (80)                       |        |           |      |              |            |                            |      |            |                              |      |            |                             |      |            |                              |      |      |        |           |      |              |            |                            |    |            |                              |    |            |                             |    |            |                              |    |
| ITEM   | SYMBOL  | CONDITION  | TYP.                       |        |           |      |              |            |                            |      |            |                              |      |            |                             |      |            |                              |      |      |        |           |      |              |            |                            |    |            |                              |    |            |                             |    |            |                              |    |
| Viewing Area                                 | $\theta x$  | $\phi=0^\circ, K \geq 5.0$   | 65                         |        |           |      |              |            |                            |      |            |                              |      |            |                             |      |            |                              |      |      |        |           |      |              |            |                            |    |            |                              |    |            |                             |    |            |                              |    |
|  | $\theta x$  | $\phi=180^\circ, K \geq 5.0$   | 65                         |        |           |      |              |            |                            |      |            |                              |      |            |                             |      |            |                              |      |      |        |           |      |              |            |                            |    |            |                              |    |            |                             |    |            |                              |    |
|  | $\theta y$  | $\phi=90^\circ, K \geq 5.0$  | 70                         |        |           |      |              |            |                            |      |            |                              |      |            |                             |      |            |                              |      |      |        |           |      |              |            |                            |    |            |                              |    |            |                             |    |            |                              |    |
|  | $\theta y$  | $\phi=270^\circ, K \geq 5.0$   | 50                         |        |           |      |              |            |                            |      |            |                              |      |            |                             |      |            |                              |      |      |        |           |      |              |            |                            |    |            |                              |    |            |                             |    |            |                              |    |
| 7B64PS2708-<br>TX14D11VM1CAA-2<br>PAGE 8-5/5 | 8.5 INTERNAL PIN CONNECTION<br>CORRECTED CN1 JAE : FA5B040HP1 → FA5B040HF1    |  |                            |        |           |      |              |            |                            |      |            |                              |      |            |                             |      |            |                              |      |      |        |           |      |              |            |                            |    |            |                              |    |            |                             |    |            |                              |    |
| 7B64PS2709-<br>TX14D11VM1CAA-2<br>PAGE 9-2/2 | 9. DIMENSIONAL OUTLINE<br>CORRECTED : The dimension of CN1<br>21.25 → (17.35) |  |                            |        |           |      |              |            |                            |      |            |                              |      |            |                             |      |            |                              |      |      |        |           |      |              |            |                            |    |            |                              |    |            |                             |    |            |                              |    |

### 3.GENERAL DATA

|                             |  |
|-----------------------------|--|
| (1) Part Name               | TX14D11VM1CAA  |
| (2) Module Dimensions       | 167.0(W)mm x 109.0(H)mm x (10.9)(D)mm max.           |
| (3) LCD Active Area         | 115.2(W)mm x 86.4(H)mm                               |
| (4) Dot Pitch               | 0.12(W)mm x 3(R,G,B)(W) x 0.36(H)mm                  |
| (5) Resolution              | 320x3(R,G,B))(W)x240(H) dots                         |
| (6) Color Pixel Arrangement | R,G,B Vertical stripe                                |
| (7) LCD Type                | Transmissive Color TFT LCD (Normally White)          |
| (8) Display Type            | Active Matrix  |
| (9) Number of Colors        | 262k Colors (R,G,B 6bit parallel)                    |
| (10) Backlight              | Cold Cathode Fluorescent Tube (U type CFL) x 1       |
| (11) Weight                 | (220)g   |
| (12) Interface              | 40pin (C-MOS)  |
| (13) Power Supply Voltage   | 3.3V only (Include Timing Controller and Power Unit) |
| (14) View Direction         | 6 O'clock  |
| (15) Touch Panel            | Resistance type                                      |
|                             | The surface is antiglare type                        |

#### 4. ABSOLUTE MAXIMUM RATINGS

##### 4.1 ELECTRICAL ABSOLUTE MAXIMUM RATINGS OF LCD

VSS=0V

| ITEM                   | SYMBOL | MIN. | MAX.    | UNIT | COMMENT    |
|------------------------|--------|------|---------|------|------------|
| Power Supply for Logic | VDD    | -0.3 | 4.0     | V    |            |
| Input Voltage          | VI     | -0.2 | VDD+0.2 |      | (Note 1)   |
| Input Current          | II     | 0    | 1       | A    |            |
| Static Electricity     | VESD0  | -    | ±100    | V    | (Note 2,3) |
|                        | VESD1  | -    | ±8      | kV   | (Note 2,4) |

Note 1 : DTMG,DCLK,RD0~RD5,GD0~GD5,BD0~BD5.

Note 2 : 200pF-250Ω 25°C - 70%RH

Note 3 : Interface Pin Connector.

Note 4 : The surface of metal bezel and LCD panel .

##### 4.2 ENVIRONMENTAL ABSOLUTE MAXIMUM RATINGS

| ITEM          | OPERATING                       |                               | STORAGE        |  | COMMENT                    |
|---------------|---------------------------------|-------------------------------|----------------|--|----------------------------|
|               | MIN.                            | MAX.                          | MIN.           | MAX.                                     |                            |
| Temperature   | -10                             | 70                            | -30            | 80                                       | (Note 2,3,6,7,8,10)        |
| Humidity      | (Note 1)                        |                               | (Note 1)       |  | Without condensation       |
| Vibration     | -                               | 4.9m/s <sup>2</sup><br>(0.5G) | -              | 19.6m/s <sup>2</sup><br>(2G)<br>(Note 5) | (Note 4)                   |
| Shock         | -                               | 29.4m/s <sup>2</sup><br>(3G)  | -              | 490m/s <sup>2</sup><br>(50G)<br>(Note 5) | XYZ directions<br>(Note 9) |
| Corrosive Gas | Not Acceptable                  |                               | Not Acceptable |  |                            |
| CFL Lift Time | 50,000 h<br>(Average) (Note 11) |                               | -              |  | at 25°C , IL=4.0mA max.    |

Note 1 : Ta ≤ 40°C :85%RH max.

Ta > 40°C :Absolute humidity must be lower than the humidity of 85%RH at 40°C.

Note 2 : Ta at -30°C for 48h , at 80°C for 100h.

Note 3 : Background color changes slightly depending on ambient temperature.  
This phenomenon is reversible.

Note 4 : 5Hz~100Hz(Except resonance frequency)

Note 5 : This LCM will resume normal operation after finishing the test.

Note 6 : The response time will be slower as low temperature.

Note 7 : Only operation is guaranteed at operating temperature. Contrast, response time, another display quality are evaluated at +25°C.

Note 8 : When LCM is operated over 60°C ambient temperature , the ICFL of LCM should be adjusted to 3mA max.

Note 9 : Pulse Width : 10ms

Note 10 : This is panel surface temperature , not ambient temperature.

Note 11 : When brightness reached 50% of initial brightness.

## 5. ELECTRICAL CHARACTERISTICS

### 5.1 ELECTRICAL CHARACTERISTICS OF LCD

Ta=25°C, VSS=0V

| ITEM                                | SYMBOL | CONDITION    | MIN. | TYP.  | MAX. | UNIT |
|-------------------------------------|--------|--------------|------|-------|------|------|
| Power Supply Voltage                | VDD    | -            | 3.0  | 3.3   | 3.6  | V    |
| Input Voltage for Logic<br>(Note 1) | VI     | "H" level    | 2.0  | -     | VDD  | V    |
|                                     |        | "L" level    | VSS  | -     | 0.8  |      |
| Power Supply Current<br>(Note 2)    | IDD    | VDD-VSS=3.3V | -    | (150) | -    | mA   |
| Vsync Frequency                     | fV     | -            | 52   | 60    | 68   | Hz   |
| Hsync Frequency                     | fH     | -            | 13.1 | 15.2  | 17.7 | kHz  |
| DCLK Frequency                      | fCLK   | -            | 4.85 | 5.85  | 7.0  | MHz  |

Note 1 : DTMG,DCLK, RD0~RD5,GD0~GD5,BD0~BD5.

Note 2 : fV=60Hz,Ta=25°C, Pattern used as display pattern : All Black.

Note 3 : Need to make sure of flickering and rippling of display when setting the frame frequency in your set.

### 5.2 ELECTRICAL CHARACTERISTICS OF TOUCH PANEL

#### 5.2.1 OPERATING CONDITION

| ITEM              | SPECIFICATION |
|-------------------|---------------|
| Operating Voltage | 5VDC max.     |

#### 5.2.2 ELECTRICAL CHARACTERISTICS

| ITEM                           |       | SPECIFICATION | NOTE                                   |
|--------------------------------|-------|---------------|--|
| Resistance<br>Between Terminal | XR-XL | 210~640Ω      |  |
|                                | YT-YB | 240~680Ω      |  |
| Insulation Resistance          | X-Y   | 20MΩ min.     | Operating Voltage : 25V DC<br>(Note 1) |
| Linearity                      | X     | 1.5% max.     |  |
|                                | Y     | 1.5% max.     |  |
| Chattering                     |       | 10ms max.     |  |

#### 5.2.3 MECHANICAL CHARACTERISTICS

| ITEM               | SPECIFICATION | NOTE                 |
|--------------------|---------------|----------------------|
| Pen Input Pressure | 0.1 ~ 0.8N    | R0.8, Polyacetal Pen |
| Finger             | 0.1 ~ 1.0N    | R8, Silicon Rubber   |
| Surface Hardness   | 2H min.       |                      |

#### 5.2.4 OPTICAL CHARACTERISTICS

| ITEM         | SPECIFICATION | NOTE |
|--------------|---------------|------|
| Transparency | 76% min       |      |

Note 1 : Operating Voltage 5V DC.

Note 2 : Test Condition.

(a) Y axis linearity testing method , 100g , VX1-VX2=5V , VOUT=VY1.

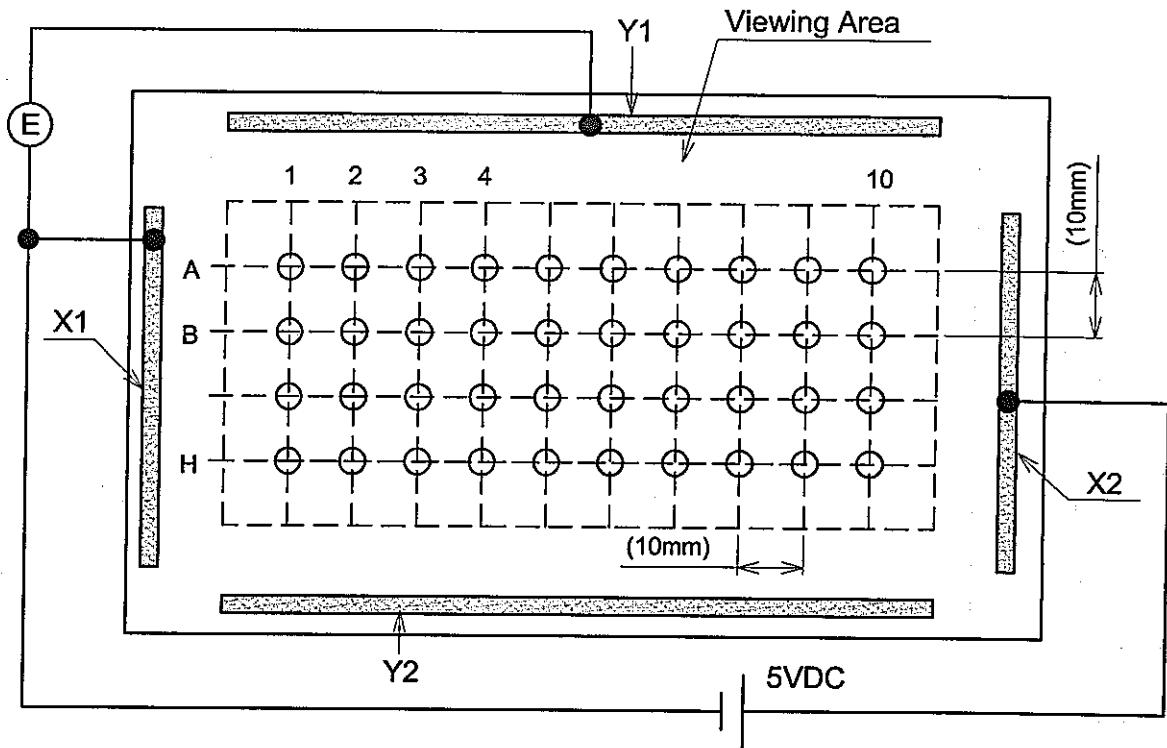

(b) X axis linearity testing method , VY1-VY2=5V , VOUT=VX1.

Note 3 : Calculation

(a) Y axis linearity

$$\text{Linearity} = \frac{\Delta E \text{ max.}}{EA - EH} \times 100(\%)$$

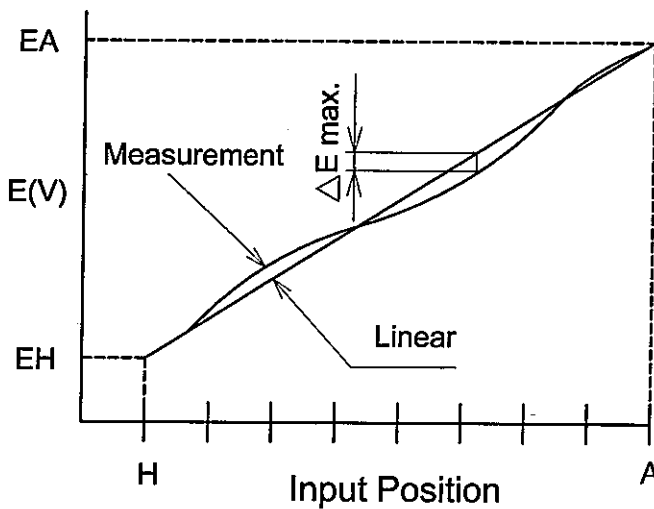

### 5.3 ELECTRICAL CHARACTERISTICS OF BACKLIGHT

| ITEM                         | SYMBOL         | MIN. | TYP. | MAX. | UNIT | NOTE    |
|------------------------------|----------------|------|------|------|------|---------|
| Lamp Voltage                 | VL             | -    | 760  | -    | Vrms | Ta=25°C |
| Frequency                    | fL             | -    | 55   | -    | KHz  |         |
| Lamp Current (1Lamp)(Note 6) | IL             | 3.0  | 4.0  | 6.0  | mA   | Ta=25°C |
| Starting Discharge Voltage   | VS<br>(Note 2) | 1300 | -    | -    | Vrms | Ta=5°C  |

Note 1 : Please design your lamp driving circuit (inverter) according to the above specifications, and inform HITACHI about it.

Note 2 : Starting discharge voltage is increased when LCM is operating under low temperature.

Please check the characteristics of your inverter before applying to your set.

Note 3 : Average life time of CFL will be decreased when LCM is operating under low temperature.

Note 4 : Under lower driving frequency of an inverter, a certain Backlight system (CFL & CFL reflection sheet) may generate a sound noise. Before designing the inverter, please consider the driving frequency and noise.

Note 5 : When IL is over 6.0mA, it may cause uneven contrast near CFL location, due to heat dispersion form CFL.

Note 6 : We recommend to equip protection circuit (To stop output) which works under abnormal operation to the inverter for CFL

## 6. OPTICAL CHARACTERISTICS

### 6.1 OPTICAL CHARACTERISTICS OF LCD

Ta=25°C (Backlight on)

| ITEM                          | SYMBOL      | CONDITION                      | MIN.                           | TYP. | MAX. | UNIT | NOTE |
|-------------------------------|-------------|--------------------------------|--------------------------------|------|------|------|------|
| Viewing Area                  | $\theta x$  | $\phi=0^\circ, K \geq 5.0$     | -                              | 65   | -    | deg  | 1~5  |
|                               | $\theta x'$ | $\phi=180^\circ, K \geq 5.0$   |                                | 65   |      | deg  | 1~5  |
|                               | $\theta y$  | $\phi=90^\circ, K \geq 5.0$    |                                | 70   |      | deg  | 1~5  |
|                               | $\theta y'$ | $\phi=270^\circ, K \geq 5.0$   | -                              | 50   | -    | deg  | 1~5  |
| Contrast Ratio                | K           | $\phi=0^\circ, \theta=0^\circ$ | 120                            | 350  | -    | -    | 5    |
| Response Time (rise+fall)     | tr+tf       | $\phi=0^\circ, \theta=0^\circ$ | -                              | (45) | -    | ms   | 6    |
| Color Tone<br>(Primary Color) | Red         | x                              | $\phi=0^\circ, \theta=0^\circ$ | -    | 0.61 | -    | -    |
|                               |             | y                              |                                | -    | 0.33 | -    | -    |
|                               | Green       | x                              |                                | -    | 0.30 | -    | -    |
|                               |             | y                              |                                | -    | 0.57 | -    | -    |
|                               | Blue        | x                              |                                | -    | 0.14 | -    | -    |
|                               |             | y                              |                                | -    | 0.08 | -    | -    |
|                               | White       | x                              |                                | -    | 0.29 | -    | -    |
|                               |             | y                              |                                | -    | 0.29 | -    | -    |

(Measurement condition : HITACHI standard)  
(Note 3~6) : See next page.

Note 1 : Driving Condition  
Display Pattern : White Raster  
ICFL Current : 4mA

Note 2 : Measurement Condition  
(Transmittance)

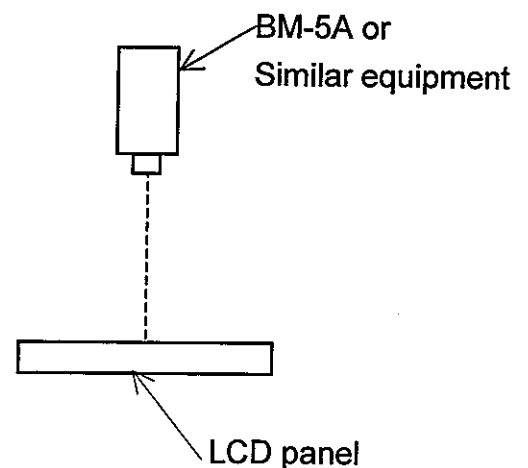



Note 3 : Definition of  $\theta$  and  $\phi$   
(Normal)  
Viewing direction

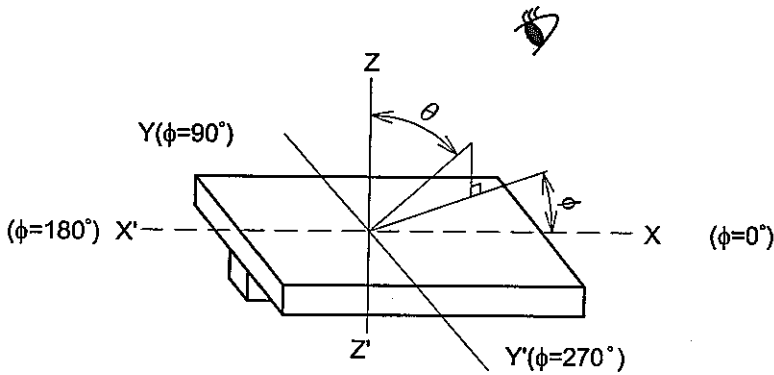

Note 5 : Definition of contrast "K"

$$K = \frac{\text{White Brightness}}{\text{Black Brightness}}$$

Note 4 : Definition of Viewing angle  $\phi_1$  and  $\phi_2$

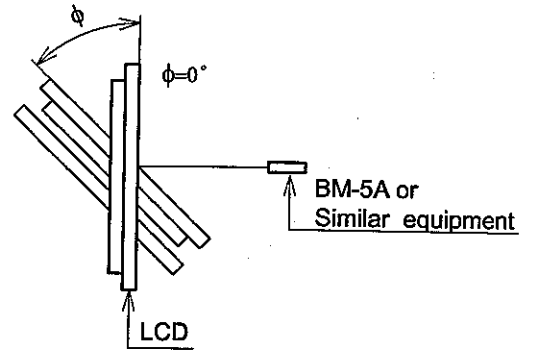
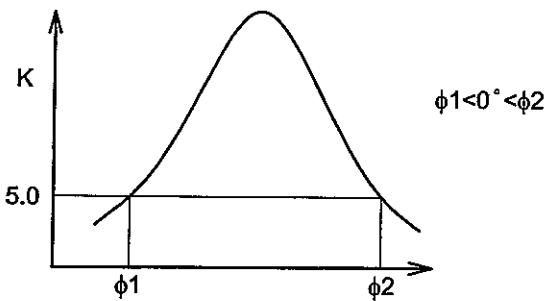

Contrast ratio "K" vs Viewing angle " $\phi$ "

Note 6 : Definition optical response time

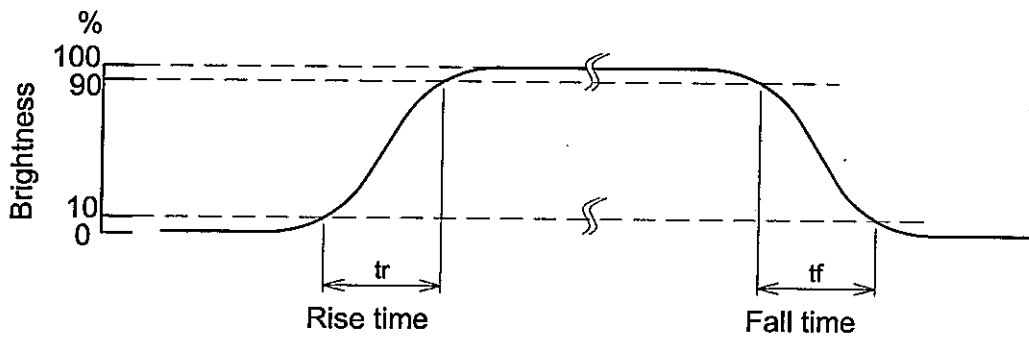
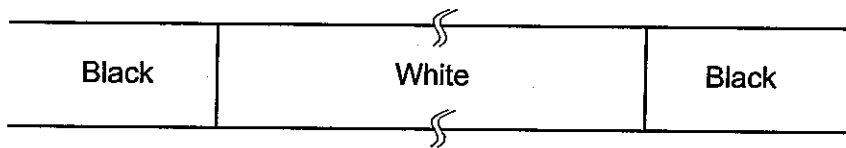

## 6.2 OPTICAL CHARACTERISTICS OF BACKLIGHT

| ITEM                  | MIN. | TYP. | MAX. | UNIT              | NOTE                          |
|-----------------------|------|------|------|-------------------|-------------------------------|
| Brightness            | -    | 280  | -    | cd/m <sup>2</sup> | IL=4.0 mA (Note 1,2)          |
| Rise Time             | -    | 3    | -    | Minute            | IL=4.0 mA<br>Brightness 80%   |
| Brightness Uniformity | -    | -    | ±25  | %                 | Under mentioned<br>(Note 1,3) |

(Measurement condition : HITACHI standard)

CFL: 0h operation, Ta=25°C

Display data should all be "ON"

Note 1 : Measurement after 10 minutes from CFL operating.

Average value of 9 points (Note 3)

Note 2 : Brightness control : 100%.

Note 3 : Measurement of the following 9 places on the display.

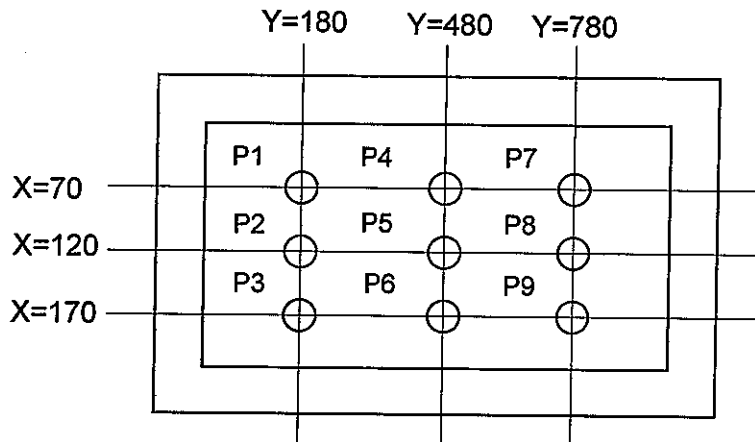

Note 4 : Definition of the brightness tolerance.

$$\left( \frac{\text{Max. brightness or Min. brightness} - \text{Average brightness}}{\text{Average brightness}} \right) \times 100$$

# 7.BLOCK DIAGRAM

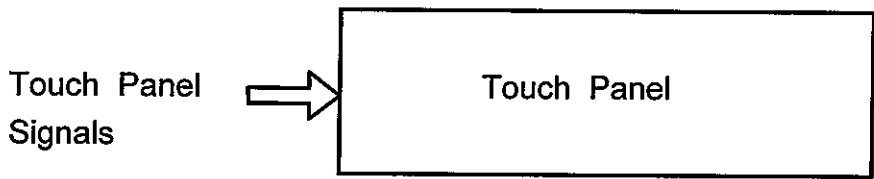
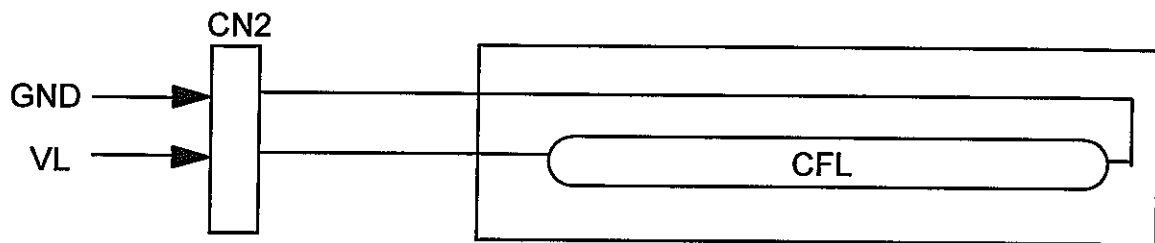
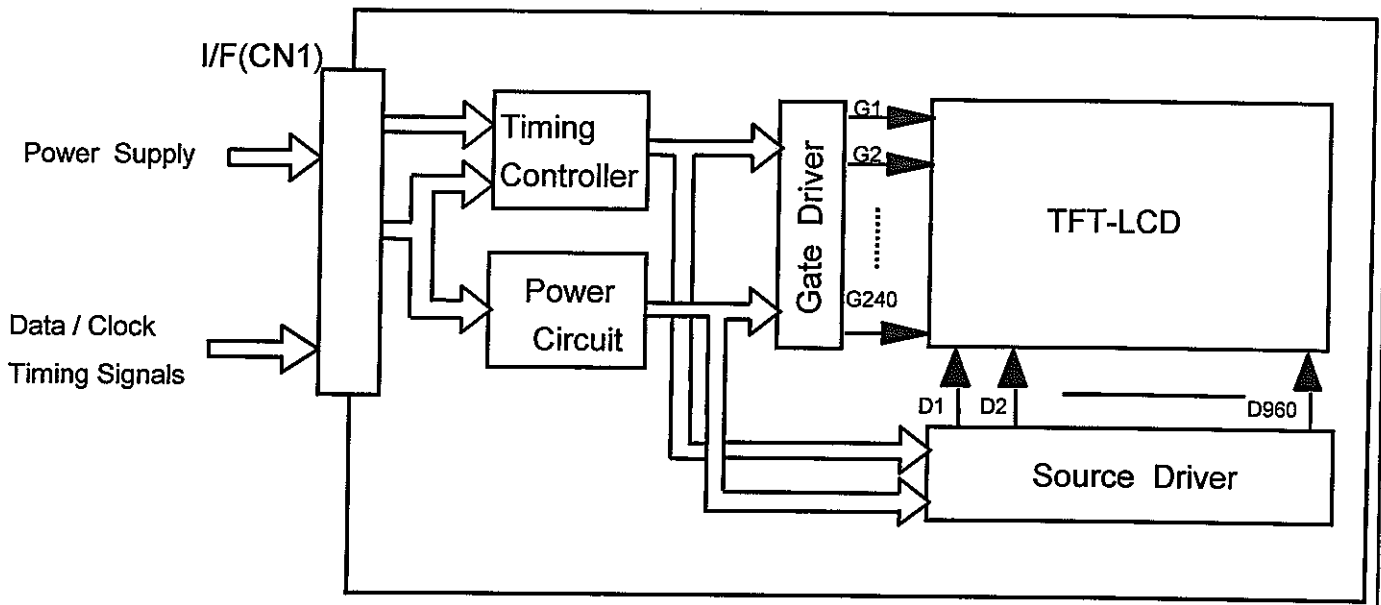

8.INTERFACE TIMING  
8.1 INTERFACE TIMING

| ITEM                 |                        | MIN.  | TYP.  | MAX.  | UNIT | SYMBOL                           | REMARKS      |
|----------------------|------------------------|-------|-------|-------|------|----------------------------------|--------------|
| DCLK                 | Cycle time             | (142) | (171) | (206) | ns   | tCLK                             |              |
|                      | Low level Width        | 12    | -     | -     |      | twCL                             |              |
|                      | High level Width       | 12    | -     | -     |      | twCH                             |              |
|                      | Rise time              | -     | -     | 25    |      | trCLK                            |              |
|                      | Fall time              | -     | -     | 25    |      | tfCLK                            |              |
|                      | Duty                   | 0.45  | 0.5   | 0.55  | -    | D                                | D= tCLK/ CLK |
| Hsync                | Set up time            | 5     |       |       | ns   | tSH                              | for DCLK     |
|                      | Hold time              | 10    |       |       |      | tHH                              |              |
|                      | Cycle                  | 370   | (385) | 397   | tCLK | tHP                              |              |
|                      | Valid width            | 4     | (5)   | -     |      | twH                              |              |
|                      | Rise/Fall time         | -     | -     | 30    | ns   | T <sub>Hr</sub> ,t <sub>Hf</sub> |              |
| Vsync                | Set up                 | 0     | -     | -     | tCLK | tSV                              | for Hsync    |
|                      | Hold                   | 2     | -     | -     |      | tHV                              |              |
|                      | Cycle                  | 251   | (253) | 261   | tHP  | tVP                              |              |
|                      | Valid width            | 2     | (2)   |       |      | twV                              |              |
|                      | Rise/Fall time         | -     | -     | 50    | ns   | t <sub>Vr</sub> ,t <sub>Vf</sub> |              |
| DTMG                 | Set up time            | 5     | -     | -     | ns   | tSI                              | for DCLK     |
|                      | Hold time              | 10    | -     | -     |      | tHI                              |              |
|                      | Rise/Fall time         | -     | -     | 30    | ns   | T <sub>Ir</sub> ,t <sub>If</sub> |              |
|                      | Horizontal back porch  | 28    | (35)  | -     | tCLK | tHBP                             |              |
|                      | Horizontal front porch | 22    | (30)  | -     |      | tHFP                             |              |
|                      | Vertical back porch    | 6     | (7)   | -     | tHP  | tVBP                             |              |
| Vertical front porch | 5                      | (6)   | -     | tVFP  |      |                                  |              |
| Data                 | Set up time            | 5     | -     | -     | ns   | tSD                              | for DCLK     |
|                      | Hold time              | 10    | -     | -     |      | tHD                              |              |
|                      | Rise/Fall time         | -     | -     | 25    | ns   | T <sub>Dr</sub> ,t <sub>Df</sub> |              |

Note : Vsync Cycle No. should be set to odd.

## 8.2 Timing Chart (Data is latched negative edge trigger of DCLK)

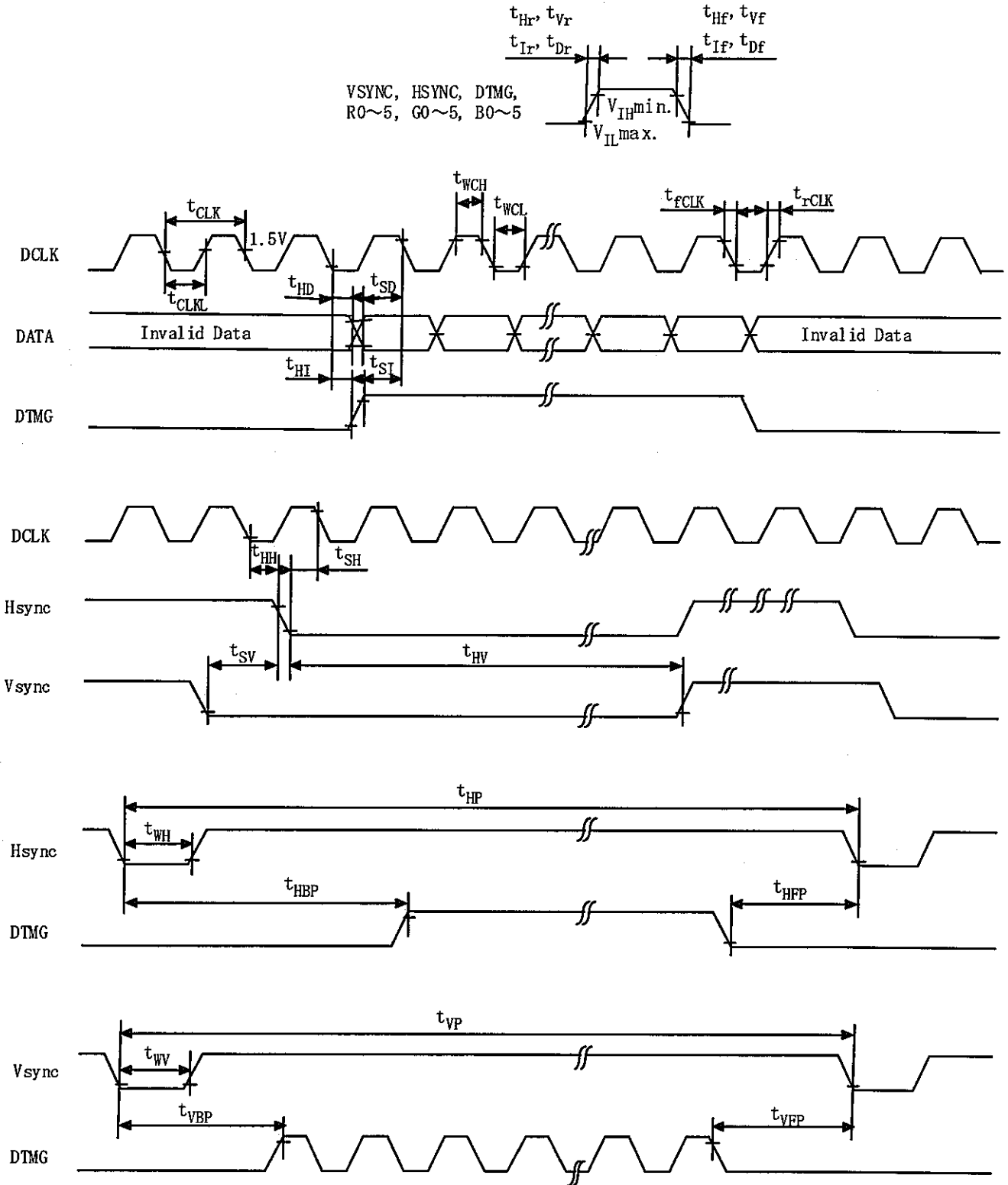

Note 1 : DTMG is definition of the above timing for Hsync and Vsync.

Note 2 : No matter when Hsync and Vsync is inputted ,this LCM can be drove only DTMG Signal. DTMG should be set to low level when it is not input valid data.

### 8.3 POWER ON/OFF SEQUENCE

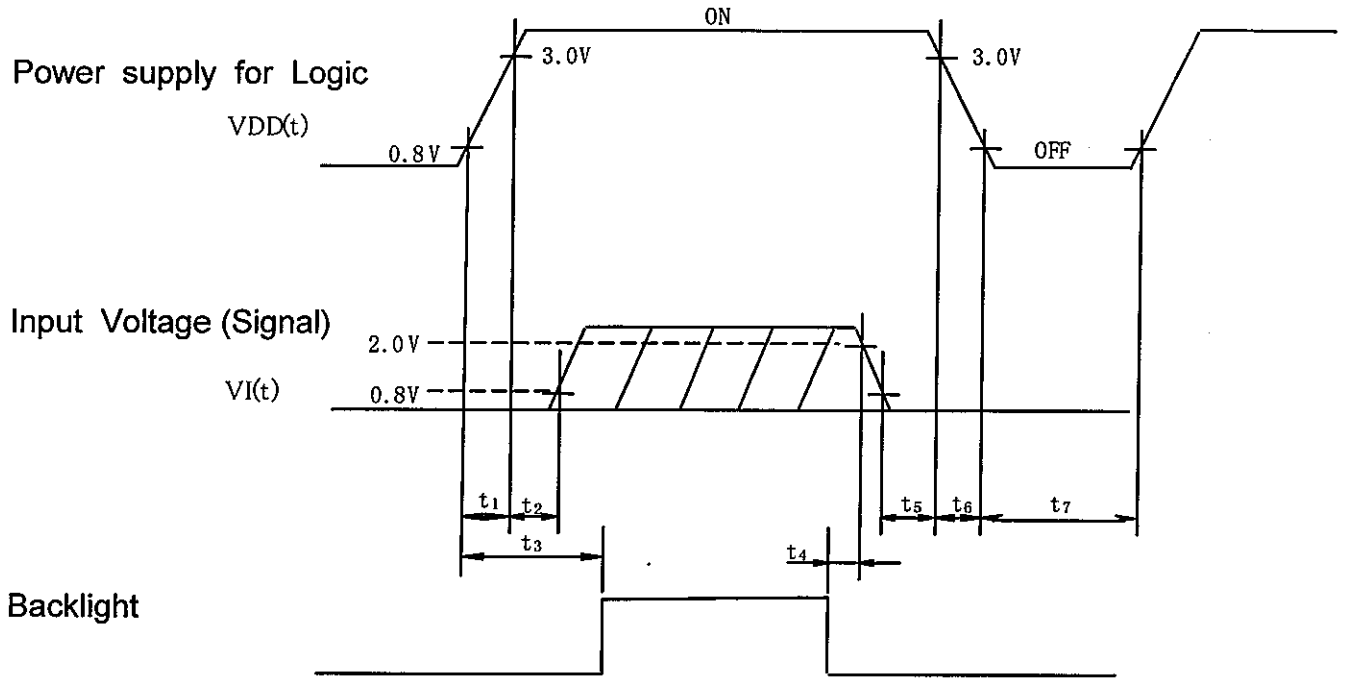

**POWER ON**

- $t_1 \leq 15\text{ms}$
- $0\text{ms} < t_2 \leq 45\text{ms}$
- $0.1\text{s} \leq t_3$

**POWER OFF**

- $5\text{ms} \leq t_4$
- $0\text{ms} \leq t_5 \leq 45\text{ms}$
- $0\text{ms} \leq t_6 \leq 20\text{ms}$
- $0.4\text{s} \leq t_7$

Note 1 :  $0V \leq VI(t) \leq VDD(t)$

VI(t) and VDD(t) is a surfeit of condition for power on/off.

Note 2 : Input Voltage(Signal) should not be set high impedance when power on.

### 8.4 RELATIONSHIP BETWEEN DISPLAYED COLOR AND INPUT DATA

|             | COLOR & GRAY SCALE | GRAY SCALE LEVELS | DATA SIGNAL |    |    |    |    |    |    |    |    |    |    |    |    |    |    |    |    |    |
|-------------|--------------------|-------------------|-------------|----|----|----|----|----|----|----|----|----|----|----|----|----|----|----|----|----|
|             |                    |                   | R0          | R1 | R2 | R3 | R4 | R5 | G0 | G1 | G2 | G3 | G4 | G5 | B0 | B1 | B2 | B3 | B4 | B5 |
| Basic Color | Black              | -                 | 0           | 0  | 0  | 0  | 0  | 0  | 0  | 0  | 0  | 0  | 0  | 0  | 0  | 0  | 0  | 0  | 0  | 0  |
|             | Blue               | -                 | 0           | 0  | 0  | 0  | 0  | 0  | 0  | 0  | 0  | 0  | 0  | 0  | 1  | 1  | 1  | 1  | 1  | 1  |
|             | Green              | -                 | 0           | 0  | 0  | 0  | 0  | 0  | 1  | 1  | 1  | 1  | 1  | 1  | 0  | 0  | 0  | 0  | 0  | 0  |
|             | Cyan               | -                 | 0           | 0  | 0  | 0  | 0  | 0  | 1  | 1  | 1  | 1  | 1  | 1  | 1  | 1  | 1  | 1  | 1  | 1  |
|             | Red                | -                 | 1           | 1  | 1  | 1  | 1  | 1  | 0  | 0  | 0  | 0  | 0  | 0  | 0  | 0  | 0  | 0  | 0  | 0  |
|             | Magenta            | -                 | 1           | 1  | 1  | 1  | 1  | 1  | 0  | 0  | 0  | 0  | 0  | 0  | 1  | 1  | 1  | 1  | 1  | 1  |
|             | Yellow             | -                 | 1           | 1  | 1  | 1  | 1  | 1  | 1  | 1  | 1  | 1  | 1  | 1  | 0  | 0  | 0  | 0  | 0  | 0  |
|             | White              | -                 | 1           | 1  | 1  | 1  | 1  | 1  | 1  | 1  | 1  | 1  | 1  | 1  | 1  | 1  | 1  | 1  | 1  | 1  |
| Red         | Black              | GS0               | 0           | 0  | 0  | 0  | 0  | 0  | 0  | 0  | 0  | 0  | 0  | 0  | 0  | 0  | 0  | 0  | 0  | 0  |
|             | ↑<br>Darker        | GS1               | 1           | 1  | 0  | 0  | 0  | 0  | 0  | 0  | 0  | 0  | 0  | 0  | 0  | 0  | 0  | 0  | 0  | 0  |
|             |                    | GS2               | 0           | 1  | 0  | 0  | 0  | 0  | 0  | 0  | 0  | 0  | 0  | 0  | 0  | 0  | 0  | 0  | 0  | 0  |
|             | ↓                  |                   |             |    |    |    |    |    |    |    |    |    |    |    |    |    |    |    |    |    |
|             | ↓                  |                   |             |    |    |    |    |    |    |    |    |    |    |    |    |    |    |    |    |    |
|             | ↓                  |                   |             |    |    |    |    |    |    |    |    |    |    |    |    |    |    |    |    |    |
|             | ↓<br>Brighter      | GS61              | 1           | 0  | 1  | 1  | 1  | 1  | 0  | 0  | 0  | 0  | 0  | 0  | 0  | 0  | 0  | 0  | 0  | 0  |
|             | ↓                  | GS62              | 0           | 1  | 1  | 1  | 1  | 1  | 0  | 0  | 0  | 0  | 0  | 0  | 0  | 0  | 0  | 0  | 0  | 0  |
| Green       | GS63               | 1                 | 1           | 1  | 1  | 1  | 1  | 0  | 0  | 0  | 0  | 0  | 0  | 0  | 0  | 0  | 0  | 0  | 0  |    |
| Green       | Black              | GS0               | 0           | 0  | 0  | 0  | 0  | 0  | 0  | 0  | 0  | 0  | 0  | 0  | 0  | 0  | 0  | 0  | 0  | 0  |
|             | ↑<br>Darker        | GS1               | 0           | 0  | 0  | 0  | 0  | 0  | 1  | 0  | 0  | 0  | 0  | 0  | 0  | 0  | 0  | 0  | 0  | 0  |
|             |                    | GS2               | 0           | 0  | 0  | 0  | 0  | 0  | 0  | 1  | 0  | 0  | 0  | 0  | 0  | 0  | 0  | 0  | 0  | 0  |
|             | ↓                  |                   |             |    |    |    |    |    |    |    |    |    |    |    |    |    |    |    |    |    |
|             | ↓                  |                   |             |    |    |    |    |    |    |    |    |    |    |    |    |    |    |    |    |    |
|             | ↓                  |                   |             |    |    |    |    |    |    |    |    |    |    |    |    |    |    |    |    |    |
|             | ↓<br>Brighter      | GS61              | 0           | 0  | 0  | 0  | 0  | 0  | 1  | 0  | 1  | 1  | 1  | 1  | 0  | 0  | 0  | 0  | 0  | 0  |
|             | ↓                  | GS62              | 0           | 0  | 0  | 0  | 0  | 0  | 0  | 1  | 1  | 1  | 1  | 1  | 0  | 0  | 0  | 0  | 0  | 0  |
| Blue        | GS63               | 0                 | 0           | 0  | 0  | 0  | 0  | 1  | 1  | 1  | 1  | 1  | 1  | 0  | 0  | 0  | 0  | 0  | 0  |    |
| Blue        | Black              | GS0               | 0           | 0  | 0  | 0  | 0  | 0  | 0  | 0  | 0  | 0  | 0  | 0  | 0  | 0  | 0  | 0  | 0  | 0  |
|             | ↑<br>Darker        | GS1               | 0           | 0  | 0  | 0  | 0  | 0  | 0  | 0  | 0  | 0  | 0  | 0  | 1  | 0  | 0  | 0  | 0  | 0  |
|             |                    | GS2               | 0           | 0  | 0  | 0  | 0  | 0  | 0  | 0  | 0  | 0  | 0  | 0  | 0  | 1  | 0  | 0  | 0  | 0  |
|             | ↓                  |                   |             |    |    |    |    |    |    |    |    |    |    |    |    |    |    |    |    |    |
|             | ↓                  |                   |             |    |    |    |    |    |    |    |    |    |    |    |    |    |    |    |    |    |
|             | ↓                  |                   |             |    |    |    |    |    |    |    |    |    |    |    |    |    |    |    |    |    |
|             | ↓<br>Brighter      | GS61              | 0           | 0  | 0  | 0  | 0  | 0  | 0  | 0  | 0  | 0  | 0  | 0  | 1  | 0  | 1  | 1  | 1  | 1  |
|             | ↓                  | GS62              | 0           | 0  | 0  | 0  | 0  | 0  | 0  | 0  | 0  | 0  | 0  | 0  | 0  | 1  | 1  | 1  | 1  | 1  |
| White       | GS63               | 0                 | 0           | 0  | 0  | 0  | 0  | 0  | 0  | 0  | 0  | 0  | 0  | 1  | 1  | 1  | 1  | 1  | 1  |    |

### 8.5 INTERNAL PIN CONNECTION

CN1 JAE : FA5B040HF1(Suitable FPC : t:0.3±0.03mm , 0.5±0.03mm pitch)

| PIN No. | SIGNAL | FUNCTION               |
|---------|--------|------------------------|
| 1       | VDD    | Power Supply for Logic |
| 2       | VDD    | Power Supply for Logic |
| 3       | VDD    | Power Supply for Logic |
| 4       | VDD    | Power Supply for Logic |
| 5       | NC     | No Connection          |
| 6       | DTMG   | Timing Signal for Data |
| 7       | VSS    | GND                    |
| 8       | DCLK   | Dot Clock              |
| 9       | VSS    | GND                    |
| 10      | NC     | No Connection          |
| 11      | VSS    | GND                    |
| 12      | B5     | Blue Data              |
| 13      | B4     |                        |
| 14      | B3     |                        |
| 15      | VSS    | GND                    |
| 16      | B2     | Blue Data              |
| 17      | B1     |                        |
| 18      | B0     |                        |
| 19      | VSS    | GND                    |
| 20      | G5     | Green Data             |
| 21      | G4     |                        |
| 22      | G3     |                        |
| 23      | VSS    | GND                    |
| 24      | G2     | Green Data             |
| 25      | G1     |                        |
| 26      | G0     |                        |
| 27      | VSS    | GND                    |
| 28      | R5     | Red Data               |
| 29      | R4     |                        |
| 30      | R3     |                        |
| 31      | VSS    | GND                    |
| 32      | R2     | Red Data               |
| 33      | R1     |                        |
| 34      | R0     |                        |
| 35      | (IC)   | No Connection          |
| 36      | VSS    | GND                    |
| 37      | NC     | No Connection          |
| 38      | NC     | No Connection          |
| 39      | NC     | No Connection          |
| 40      | NC     | No Connection          |

CN2 JST Housing : BHR-03VS-1

| PIN No. | SIGNAL | LEVEL | FUNCTION             |
|---------|--------|-------|----------------------|
| 1       | VCFL   | -     | Power Supply for CFL |
| 2       | NC     | -     | No connection        |
| 3       | VSS    | -     | GND for CFL          |



# 9. DIMENSIONAL OUTLINE

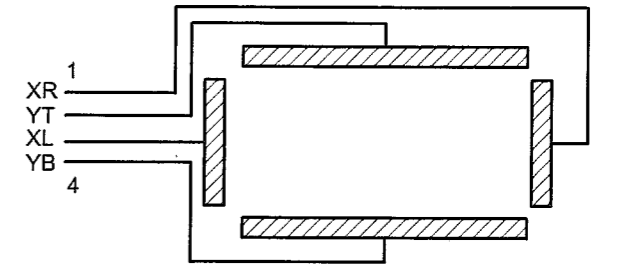
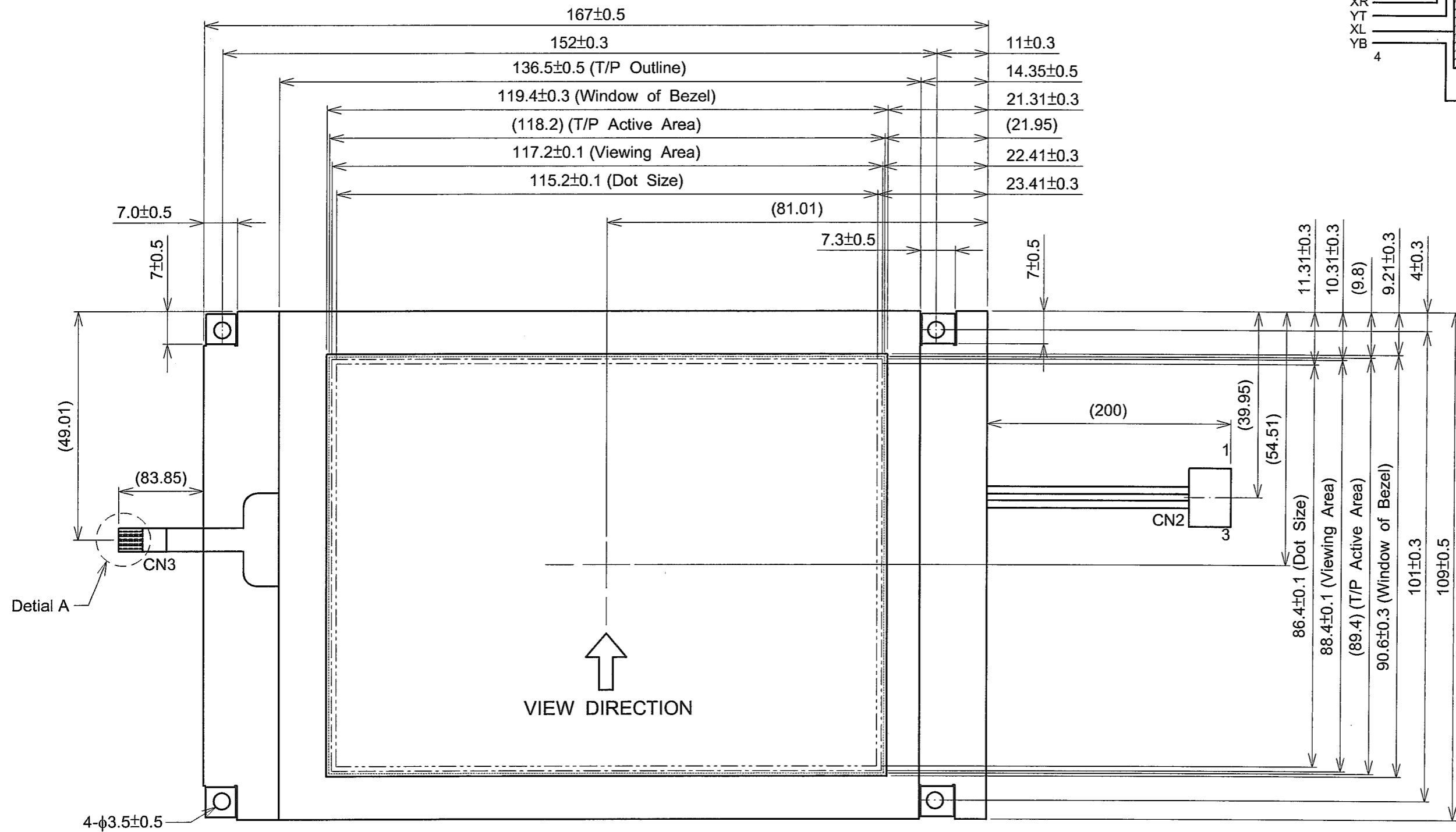

Top View

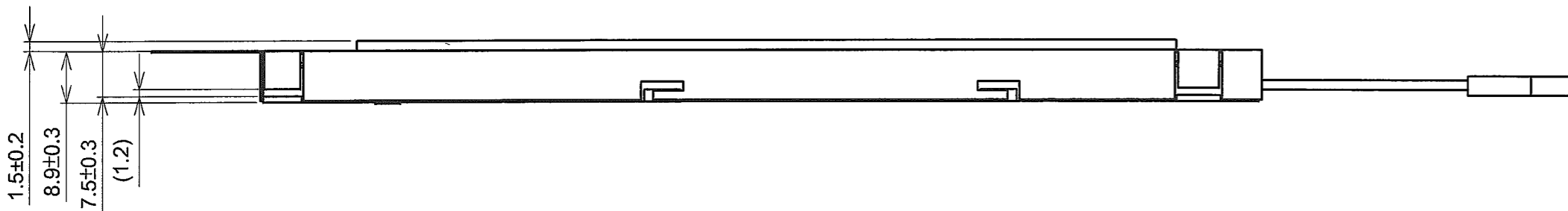
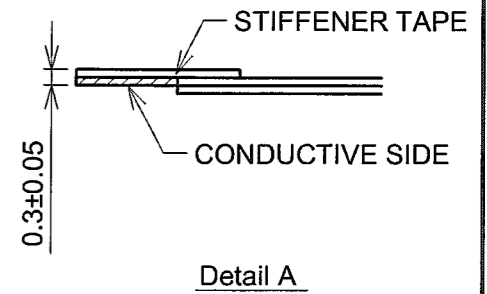
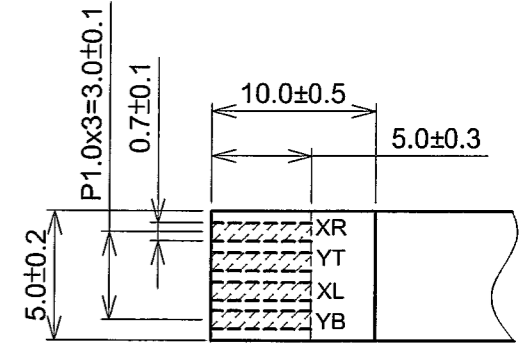

Scale : NTS  
Unit : mm

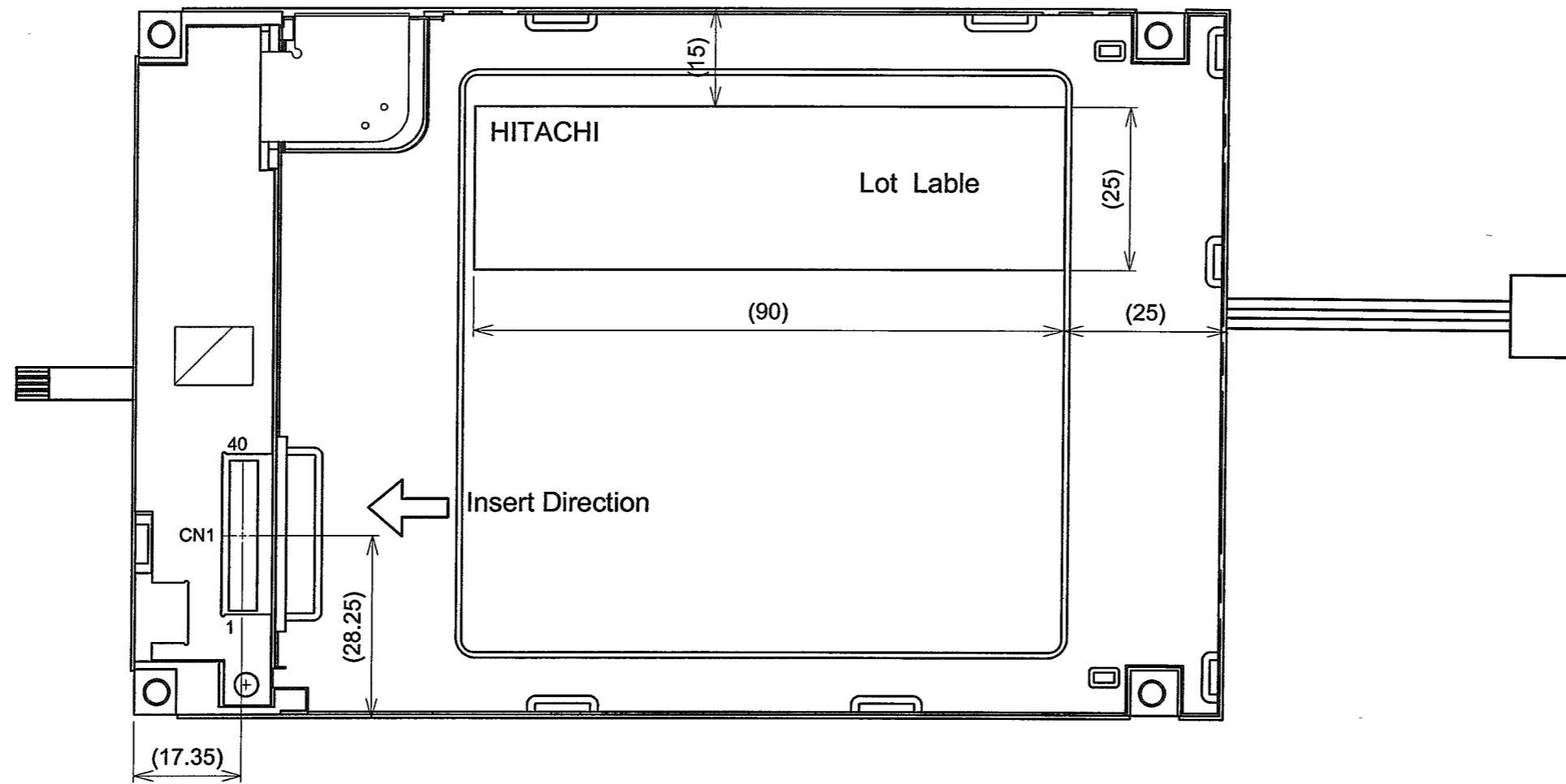

Scale : NTS  
Unit : mm

## 10. APPEARANCE STANDARD

### 10.1 APPEARANCE INSPECTION CONDITION

Visual inspection should be done under the following condition.

- (1) The inspection should be done in a dark room.(More than 1000(lx) and non-directive)
- (2) The distance between eyes of an inspector and the LCD module is 30cm.
- (3) The viewing zone is shown the figure.

The  $\theta$  is defined as  $\theta \leq 45^\circ$  for LCM power off

$\theta \leq 5^\circ$  for LCM power on

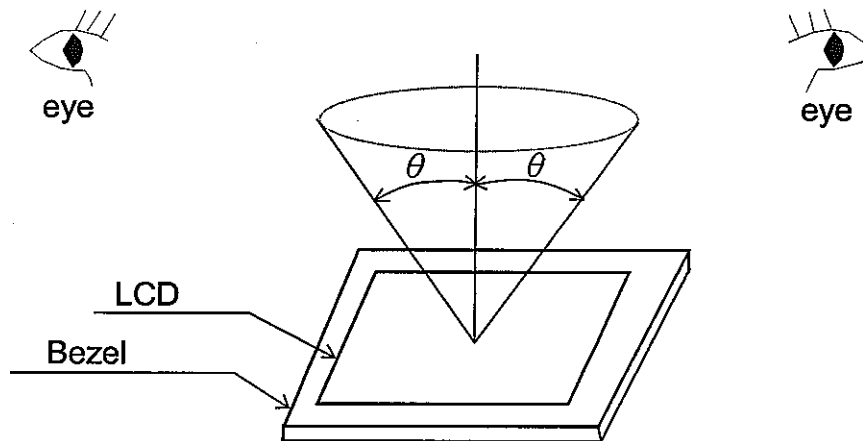

### 10.2 DEFINITION OF ZONE

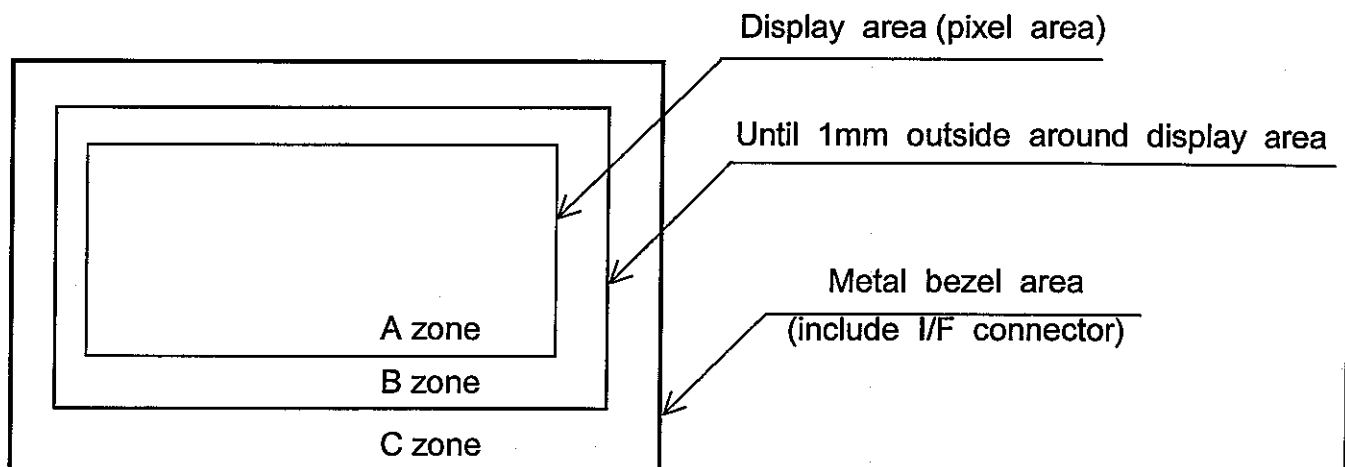

### 10.3 APPEARANCE SPECIFICATION

#### (1)LCD Appearance

\*) If the problem related to this section occurs about this item, the responsible persons of both party (Customer and HITACHI) will discuss the matter in detail.

| No.                  | ITEM                                  | CRITERIA  |                                 |                                 |                  | APPLIED ZONE |
|----------------------|---------------------------------------|---|---------------------------------|---------------------------------|------------------|--------------|
| L<br>C<br>D          | Scratches                             | Length<br>L(mm)   | Width<br>W(mm)                  | Maximum<br>number<br>acceptable | Minimum<br>space | A,B          |
|                      |                                       | Ignored   | $W \leq 0.02$                   | Ignored                         | -                |              |
|                      |                                       | $L \leq 40$   | $0.02 < W \leq 0.04$            | 10                              | -                |              |
|                      |                                       | $L \leq 20$   | $W \leq 0.04$                   | 10                              | -                |              |
|                      | Dent                                  | Distinguished one is acceptable<br>(To be judged by HITACHI standard) |                                 |                                 |                  | A            |
|                      | Wrinkles in Polarizer                 | Same as above   |                                 |                                 |                  | A            |
|                      | Bubbles                               | Average diameter<br>D(mm)   |                                 | Maximum number<br>acceptable    |                  | A            |
|                      |                                       | $D \leq 0.2$  |                                 | Ignored                         |                  |              |
|                      |                                       | $0.2 < D \leq 0.3$  |                                 | 12                              |                  |              |
|                      |                                       | $0.3 < D \leq 0.5$  |                                 | 3                               |                  |              |
|                      |                                       | $0.5 < D$   |                                 | none                            |                  |              |
|                      | Stains<br>Foreign<br>Materials        | Filamentous (Line shape)  |                                 |                                 |                  | A,B          |
|                      |                                       | Length<br>L(mm)   | Width<br>W(mm)                  | Maximum number<br>acceptable    |                  |              |
|                      | Dark Spot                             | $L \leq 2.0$  | $W \leq 0.03$                   | Ignored                         |                  |              |
|                      |                                       | $L \leq 3.0$  | $0.03 < W \leq 0.05$            | 6                               |                  |              |
|                      |                                       | $L \leq 2.5$  | $0.05 < W \leq 0.1$             | 1                               |                  |              |
|                      | Dot Defect                            | Round(Dot shape)  |                                 |                                 |                  | A,B          |
|                      |                                       | Average diameter<br>D(mm)   | Maximum number<br>acceptable    | Minimum Space                   |                  |              |
|                      |                                       | $D < 0.2$   | Ignored                         | -                               |                  |              |
|                      |                                       | $0.2 \leq D < 0.3$  | 10                              | 10 mm                           |                  |              |
|                      |                                       | $0.3 \leq D < 0.4$  | 5                               | 30 mm                           |                  |              |
|                      |                                       | $0.4 \leq D$  | none                            | -                               |                  |              |
|                      |                                       | The total number  | Filamentous + Round=10          |                                 |                  |              |
|                      | Those wiped out easily are acceptable |   |                                 |                                 |                  |              |
| Color Tone           | To be judged by HITACHI STANDARD      |   |                                 |                                 | A                |              |
| Color Uniformity     | Same as above                         |   |                                 |                                 | A                |              |
| Dot Defect           |                                       |   | Maximum<br>number<br>acceptable |                                 | A                |              |
|                      | Sparkle mode                          | 1 dot   |                                 | 4                               |                  |              |
|                      |                                       | 2 dots  |                                 | 1                               |                  |              |
|                      |                                       | Total (Note.(3)-(f))  |                                 | 5                               |                  |              |
|                      | Black mode                            | 1 dot   |                                 | 5                               |                  |              |
|                      |                                       | 2 dots  |                                 | 2                               |                  |              |
|                      |                                       | Total (Note.(3)-(f))  |                                 | 5                               |                  |              |
| Total (Note.(3)-(f)) |                                       | 10  |                                 |                                 |                  |              |

(2) CFL BACKLIGHT APPEARANCE

| No.                                       | ITEM                        | CRITERIA                  |                 |                              | APPLIED ZONE |
|---|-----------------------------|---------------------------|-----------------|------------------------------|--------------|
| C<br>F<br>L                               | Dark Spots                  | Average diameter<br>D(mm) |                 | Maximum number acceptable    | A            |
|   | White Spots                 | $D \leq 0.4$              |                 | ignored                      |              |
|   | Foreign Materials<br>(Spot) | $0.4 < D$                 |                 | none                         |              |
| B<br>A<br>C<br>K<br>L<br>I<br>G<br>H<br>T | Foreign Materials<br>(Line) | Width<br>W(mm)            | Length<br>L(mm) | Maximum number<br>acceptable | A            |
|   |                             | $W \leq 0.2$              | $L \leq 2.5$    | 1                            |              |
|   |                             | $0.2 < W$                 | -               | None<br>none                 |              |
| S<br>C<br>R<br>A<br>T<br>C<br>H<br>E<br>S | Scratches                   | Width<br>W(mm)            | Length<br>L(mm) | Maximum number<br>acceptable | A            |
|   |                             | $W \leq 0.1$              | -               | ignored                      |              |
|   |                             | $0.1 < W \leq 0.2$        | $L \leq 11.0$   | 1                            |              |
|   |                             | $0.2 < W$                 | $11.0 < L$      | None<br>none                 |              |

(3) Touch panel appearance

Visual inspection should be done under the following condition.

- \*) The inspection should be done in a dark room. (more than 500 lx) and non-directive)
- \*) The distance between eyes of an inspector and the LCD module is 30 cm.
- \*) The viewing angle  $\leq 60^\circ$ .

| No.                          | ITEM                             | CRITERIA                      |                              |                              | APPLIED ZONE |
|------------------------------|----------------------------------|-------------------------------|------------------------------|------------------------------|--------------|
| TOUCH PANEL                  | Scratches                        | Width<br>W(mm)                | Length<br>L(mm)              | Maximum number<br>acceptable | A,B          |
|                              |                                  | $W > 0.1$                     | $L \geq 10$                  | None                         |              |
|                              |                                  | $0.10 \geq W > 0.05$          | $L < 10$                     | 4 pcs max.                   |              |
|                              |                                  | $0.05 \geq W$                 | $L < 10$                     | Ignored                      |              |
|                              | Foreign Materials<br>Dark Spot   | Filamentous (Line shape)      |                              |                              | A,B          |
|                              |                                  | Width<br>W(mm)                | Length<br>L(mm)              | Maximum number<br>acceptable |              |
|                              |                                  | $W > 0.10$                    | -                            | Dust (circular)              |              |
|                              |                                  | $0.10 \geq W > 0.05$          | $3 < L$                      | None                         |              |
|                              |                                  | $0.05 \geq W$                 | $L \leq 3$                   | Ignored                      |              |
|                              |                                  | Round(Dot shape)              |                              |                              |              |
|                              |                                  | Average diameter<br>D(mm)     | Maximum number<br>acceptable |                              | A,B          |
|                              |                                  | $D > 0.35$                    | None                         |                              |              |
|                              |                                  | $0.35 \geq D > 0.25$          | 6 psc max.                   |                              |              |
|                              |                                  | $D \leq 0.25$                 | Ignored                      |                              |              |
|                              | Newton Ring<br>(Touch Panel)     | Need to discuss with customer |                              |                              | A,B          |
| Touch Panel<br>Uncleanliness | No conspicuous dirt              |                               |                              | A                            |              |
| Rubbing Scratch              | To be judged by HITACHI standard |                               |                              | -                            |              |

(4) Glass indentation

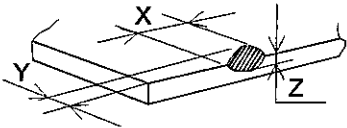
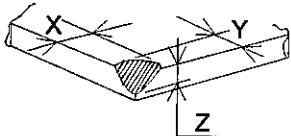
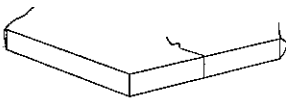
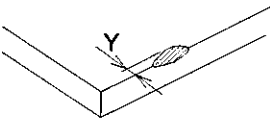
| ITEM               | SPECIFICATIONS  |            |            |            |
|--------------------|---|------------|------------|------------|
| Common Indentation |  | X          | Y          | Z          |
|                    |   | $\leq 5.0$ | $\leq 3.0$ | $\leq 1.1$ |
| Corner Broken      |  | X          | Y          | Z          |
|                    |   | $\leq 3$   | $\leq 3$   | $\leq 1.1$ |
| Proceeding Crack   |  | None       |            |            |
| Other              |  | $Y \leq 1$ |            |            |

### Blistering Puffiness

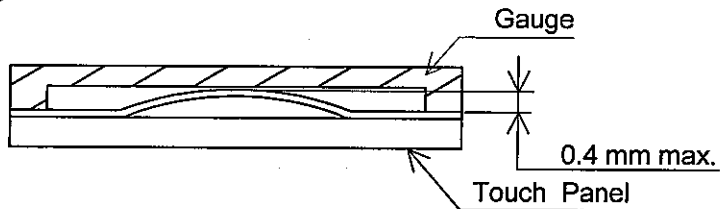

Note 1 : Definition of average diameter (D)

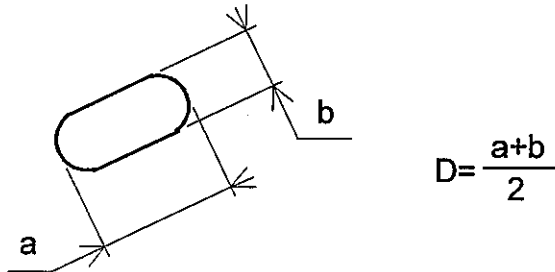

Note 2 : Definition of length (L) and width (W)

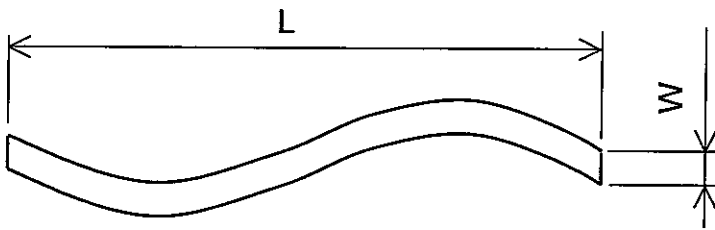

Note 3 : Definition of dot defect

- (a) Dot Defect : Defect Area > 1/2 dot
- (b) Sparkle mode : Brightness of dot is more than 30% at Black raster.
- (c) Black mode : Brightness of dot is less than 70% at R.G.B raster.
- (d) 1 dot : Defect dot is isolated , not attached to other defect dot.
- (e) N dot : N defect dots are consecutive (fig.1).

(N means the number of defect dots.)

( fig .1)

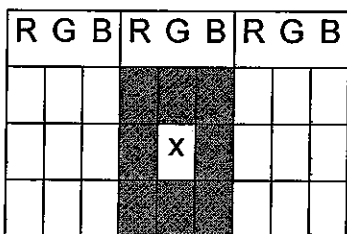

2 dots defect included defect dot "X" is defined as follows.

Adjacent dots to defect dot "X" :

(f) Counting definition of adjacent dots (1 set) : same as 1 dot defect.

(g) Those wiped out easily are acceptable.

## 11. PRECAUTION IN DESIGN

### 11.1 MOUNTING PRECAUTION

Please mount the LCD Module by using mounting holes provided. While mounting please pay attention to the followings.

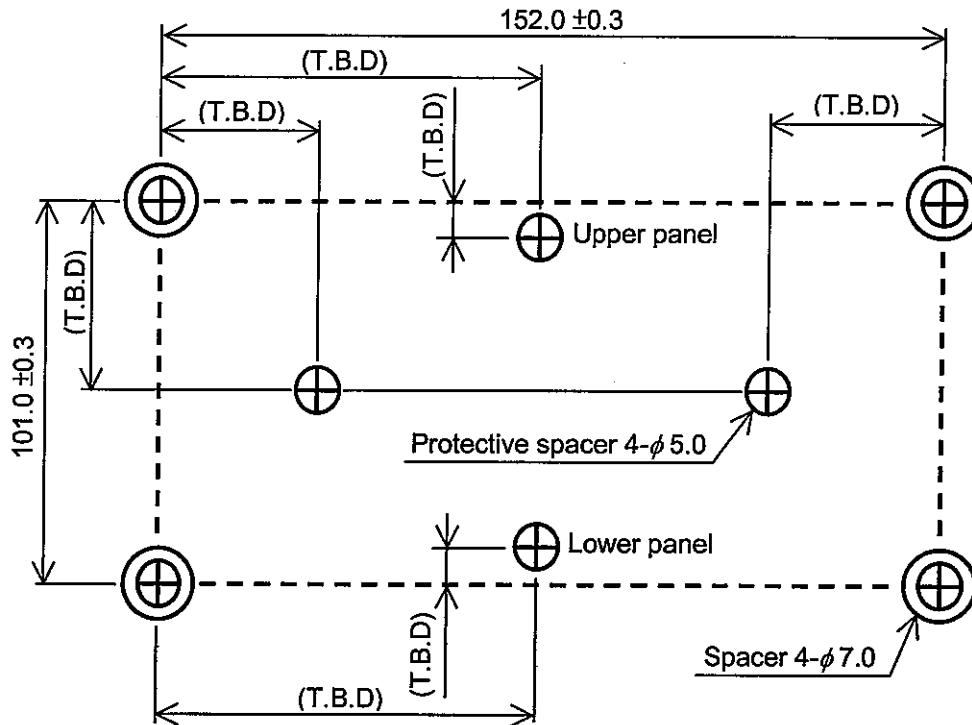
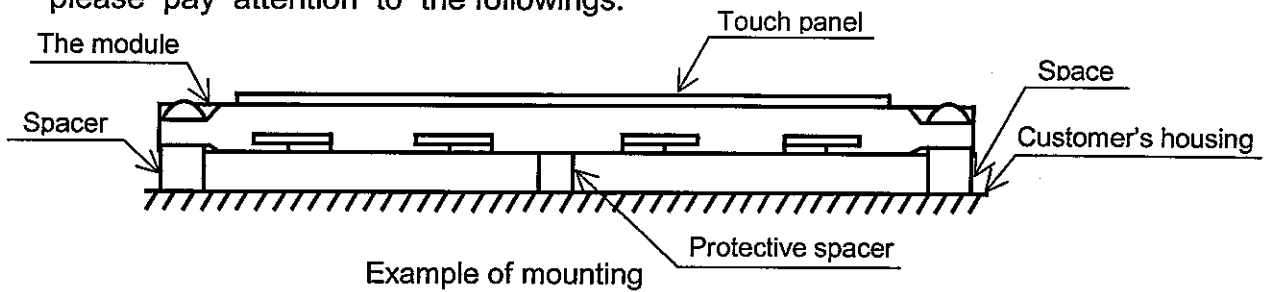

Unit : mm

Scale: NTS

Location of spacers

- (1) To prevent the module cover from being pressed, the distance between the module and the fitting plate, which means the length of the spacers, should be shorter than 1.0mm.
- (2) The use of protective spacers are recommend in order to protect the module from shock.
- (3) For the module to be used at upright position, the case shall have a structure where the touch panel screen does not shift with its own weight.

### 11.2 PRECAUTIONS AGAINST ELECTROSTATIC DISCHARGE

As this module contains C-MOS LSIs, it is not strong against electrostatic discharge. Make certain that the operator's body is connected to the ground through a list band , etc. And don't touch I/F pins directly.



### 11.3 HANDLING PRECAUTIONS

- (1) Since the Touch Panel on the top, and the frame on the bottom tend to be easily damaged, they should be with full care so as not to get them touched, pushed or rubbed by a piece on glass, tweezers and anything else which are harder a pencil lead 2H.
- (2) As the adhesives used for adhering upper/lower polarizer's and frame are made of organic substances which will be deteriorated by a chemical reaction with such chemicals as acetone, toluene, ethanol and isopropyl alcohol. The following are recommended for use :  
normal hexane  
Please contact with us when it is necessary for you to use chemicals other than the above.
- (3) Lightly wipe to clean the dirty surface with absorbent cotton or other soft material like chamois, soaked in the recommended chemicals without scrubbing it hardly. Always wipe the surface horizontally or vertically. Never give a wipe in a circle. To prevent the display surface from damage and keep the appearance in good state, it is sufficient, in general, to wipe it with absorbent cotton.
- (4) Immediately wipe off saliva or water drop attached on the display area because it may cause deformation or faded color.
- (5) Foggy dew deposited on the surface may cause a damage, stain or dirt to the polarizer.  
When you need to take out the LCD module from some place at low temperature for test, etc.  
It is required to be warmed them up to temperature higher than room temperature before taking them out.
- (6) Touching the display area or I/F pins with bare hands or contaminating them are prohibited, because the stain on the display area and poor insulation between terminals are often caused by being touched with bare hands.  
(Some cosmetics are detrimental to polarizer's.)
- (7) In general, the glass is fragile so that, especially on its periphery, tends to be cracked or chipped in handling. Please not give the LCD module sharp shocks by falling, etc.
- (8) Maximum pressure to the surface must be less than  $1.96 \times 10^4$  Pa.  
And if the pressure area is less than  $1\text{cm}^2$ , maximum pressure must be less than 1.96N.
- (9) Since the metal width is narrow on these locations (see page 9-1/2), please careful with handling.
- (10) Top sheets shall be cleaned gently using a soft cloth such as those used for glasses.  
Hard wiping accumulated dust will leave scars on the surface even using a cloth.

#### 11.4 OPERATION PRECAUTION

- (1) Using a LCM module beyond its maximum ratings may result in its permanent destruction.  
LCM module's should usually be used under recommended operating conditions shown in chapter 4. Exceeding any of these conditions may adversely affect its reliability.
- (2) Response time will be extremely delayed at lower temperature than the specified operating temperature range and on the other hand LCD's shows dark blue at higher temperature.  
However those phenomena do not main defects of the LCD module. Those phenomena will disappear in the specified operating temperature range.
- (3) If the display area is pushed hard during operation, some display patterns will be abnormally display.
- (4) A slight dew depositing on terminals may cause electrochemical reaction which leads to terminal open circuit. Please operate the LCD module under the relative condition of 40°C 85%RH.
- (5) Resistance range : Your controller shall be set up to allow the resistance range of Touch Panel specified in our CAS. .
- (6) Pointed position of Touch Panel may shift owing to a change in resistance of Touch Panel depending on the operation condition . To compensate this shift, the set shall be given a calibration function.
- (7) Input shall be made with a stylus pen (poly acetal , R0.8). Chances are very high that use of a metal piece including a ball point pen or sharp edge will impair accuracy.
- (8) The Touch Panel is an auxiliary input device. The system shall be designed to have other input device.

#### 11.5 STORAGE

In case of storing LCD module for a long period of time (for instance, for years) for the purpose of replacement use, the following precautions necessary.

- (1) Store the LCD modules in a dark place; do not expose them to sunlight or ultraviolet rays.
- (2) Keep the temperature between 10°C and 35°C at normal humidity.
- (3) Store the LCD modules in the container which is used for shipping from us.
- (4) No articles shall be left on the surface over an extended period of time.

#### 11.6 SAFETY

Wear finger cots or gloves whenever handling or assembling a Touch Panel its glass edges are sharp.

|   |      |            |            |                             |      |        |
|---|------|------------|------------|-----------------------------|------|--------|
| KAOHSIUNG HITACHI<br>ELECTRONICS CO.,LTD. | DATE | Nov.28,'03 | Sh.<br>No. | 7B64PS 2711-TX14D11VM1CAA-2 | PAGE | 11-3/3 |
|---|------|------------|------------|-----------------------------|------|--------|

## 12. DESIGNATION OF LOT MARK

### 12.1 LOT MARK

Lot mark is consisted of 5 digits for production lot and 5 digits for production control.

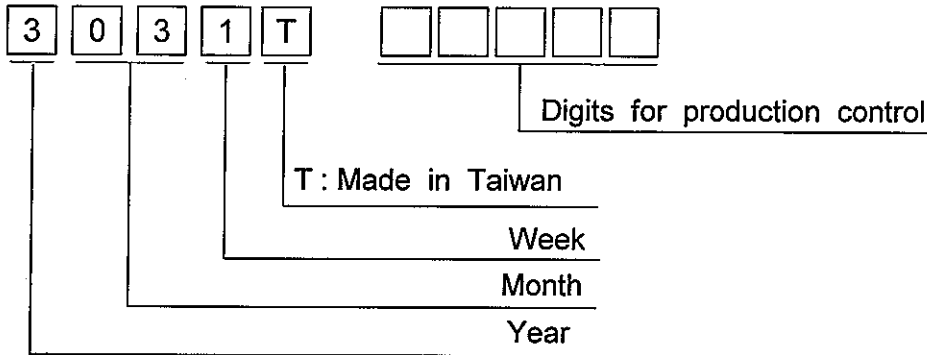

| Year | Figure in lot mark |
|------|--------------------|
| 2003 | 3                  |
| 2004 | 4                  |
| 2005 | 5                  |
| 2006 | 6                  |
| 2007 | 7                  |

| Month | Figure in lot mark | Month | Figure in lot mark |
|-------|--------------------|-------|--------------------|
| Jan.  | 01                 | Jul.  | 07                 |
| Feb.  | 02                 | Aug.  | 08                 |
| Mar.  | 03                 | Sep.  | 09                 |
| Apr.  | 04                 | Oct.  | 10                 |
| May   | 05                 | Nov.  | 11                 |
| Jun.  | 06                 | Dec.  | 12                 |

| Week (day in calendar) | Figure in lot mark |
|------------------------|--------------------|
| 1~7                    | 1                  |
| 8~14                   | 2                  |
| 15~21                  | 3                  |
| 22~28                  | 4                  |
| 29~31                  | 5                  |

### 12.2 SERIAL No.

Serial No. is consisted of 5 digits number (00001~99999).

### 12.3 LOCATION OF LOT MARK

Label is bring attached on the back side of module.

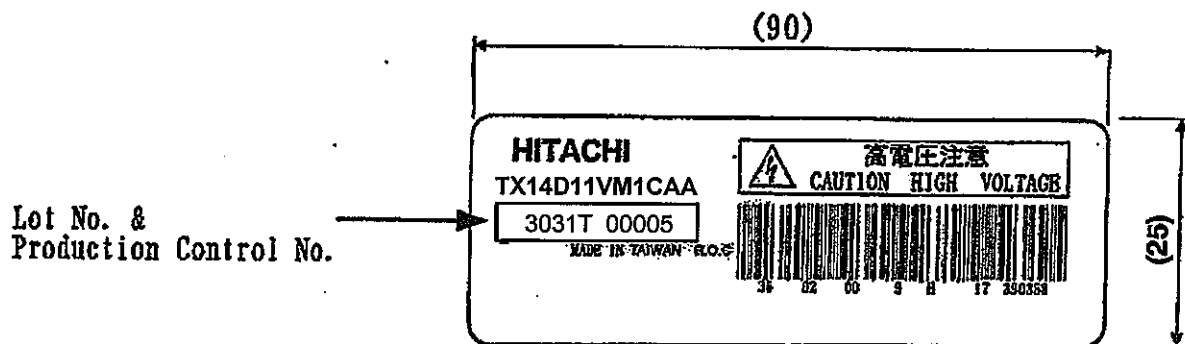

### 13. PRECAUTION FOR USE

(1) A limit sample should be provided by the both parties on an occasion when the both parties agree to its necessity.

Judgment by a limit sample shall take effect after the limit sample has been established and confirmed by the both parties.

(2) On the following occasions, the handling of the problem should be decided through discussion and agreement between responsible persons of the both parties.

(1) When a question is arisen in the specifications.

(2) When a new problem is arisen which is not specified in this specifications.

(3) When an inspection specifications change or operating condition change by customer is reported to HITACHI, and some problem is arisen in the specification due to the change.

(4) When a new problem is arisen at the customer's operating set for sample evaluation.

(3) Regarding the treatment for maintenance and repairing, both parties will discuss it in six months later after latest delivery of this product.

The precaution that should be observed when handling LCM have been explained above.

If any points are unclear or if you have any requests , please contact with HITACHI.