

TPA0252 STEREO 2-W AUDIO POWER AMPLIFIER WITH DIGITAL VOLUME CONTROL

SLOS288 – JUNE 2000

- Compatible With PC 99 Desktop Line-Out Into 10-k Ω Load
- Compatible With PC 99 Portable Into 8- Ω Load
- Digital Volume Control From 20 dB to –40 dB
- Internal Memory Restores Volume Setting After Shutdown or Power Down
- 2-W/Ch Output Power Into 3- Ω Load
- PC-Beep Input
- Depop Circuitry
- Stereo Input MUX and Output MUX
- Fully Differential Input
- Low Supply Current and Shutdown Current
- Surface-Mount Power Packaging
24-Pin TSSOP PowerPAD™

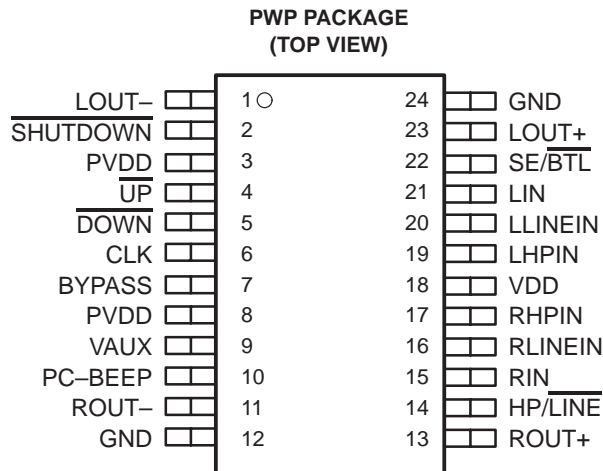

description

The TPA0252 is a stereo audio power amplifier in a 24-pin TSSOP thermally enhanced package capable of delivering 2 W of continuous RMS power per channel into 3- Ω loads. This device minimizes the number of external components needed, which simplifies the design and frees up board space for other features. When driving 1 W into 8- Ω speakers, the TPA0252 has less than 0.3% THD+N across its specified frequency range.

Included within this device is integrated depop circuitry that virtually eliminates transients that cause noise in the speakers.

Amplifier gain is controlled by two terminals, \overline{UP} and \overline{DOWN} . There are 31 discrete steps covering the range of 20 dB (maximum volume setting) to –40 dB (minimum volume setting) in 2 dB steps. By pressing either button momentarily, the volume steps up or down 2 dB. By continuing to hold the button down, the device will start stepping through volume settings at a rate determined by the capacitor on the CLK terminal. An internal input MUX, controlled by the HP/LINE pin, allows two sets of stereo inputs to the amplifier. In notebook applications, where internal speakers are driven as BTL and the line outputs (often headphone drive) are required to be SE, the TPA0252 automatically switches into SE mode when the SE/BTL input is activated. This effectively reduces the gain by 6 dB. The TPA0252 restores previous volume setting if VAUX is greater than 3 V even if the device is shut-down and/or V_{DD} is removed. If VAUX goes low, the default gain is –10 dB.

The TPA0252 consumes only 9 mA of supply current during normal operation. A miserly shutdown mode is included that reduces the supply current to less than 150 μ A.

The PowerPAD™ package (PWP) delivers a level of thermal performance that was previously achievable only in TO-220-type packages. Thermal impedances of approximately 35°C/W are truly realized in multilayer PCB applications. This allows the TPA0252 to operate at full power into 8- Ω loads at ambient temperatures of 85°C.



Please be aware that an important notice concerning availability, standard warranty, and use in critical applications of Texas Instruments semiconductor products and disclaimers thereto appears at the end of this data sheet.

PowerPAD is a trademark of Texas Instruments.

PRODUCTION DATA information is current as of publication date. Products conform to specifications per the terms of Texas Instruments standard warranty. Production processing does not necessarily include testing of all parameters.

 **TEXAS
INSTRUMENTS**

POST OFFICE BOX 655303 • DALLAS, TEXAS 75265

Copyright © 2000, Texas Instruments Incorporated

TPA0252 STEREO 2-W AUDIO POWER AMPLIFIER WITH DIGITAL VOLUME CONTROL

SLOS288 – JUNE 2000

functional block diagram

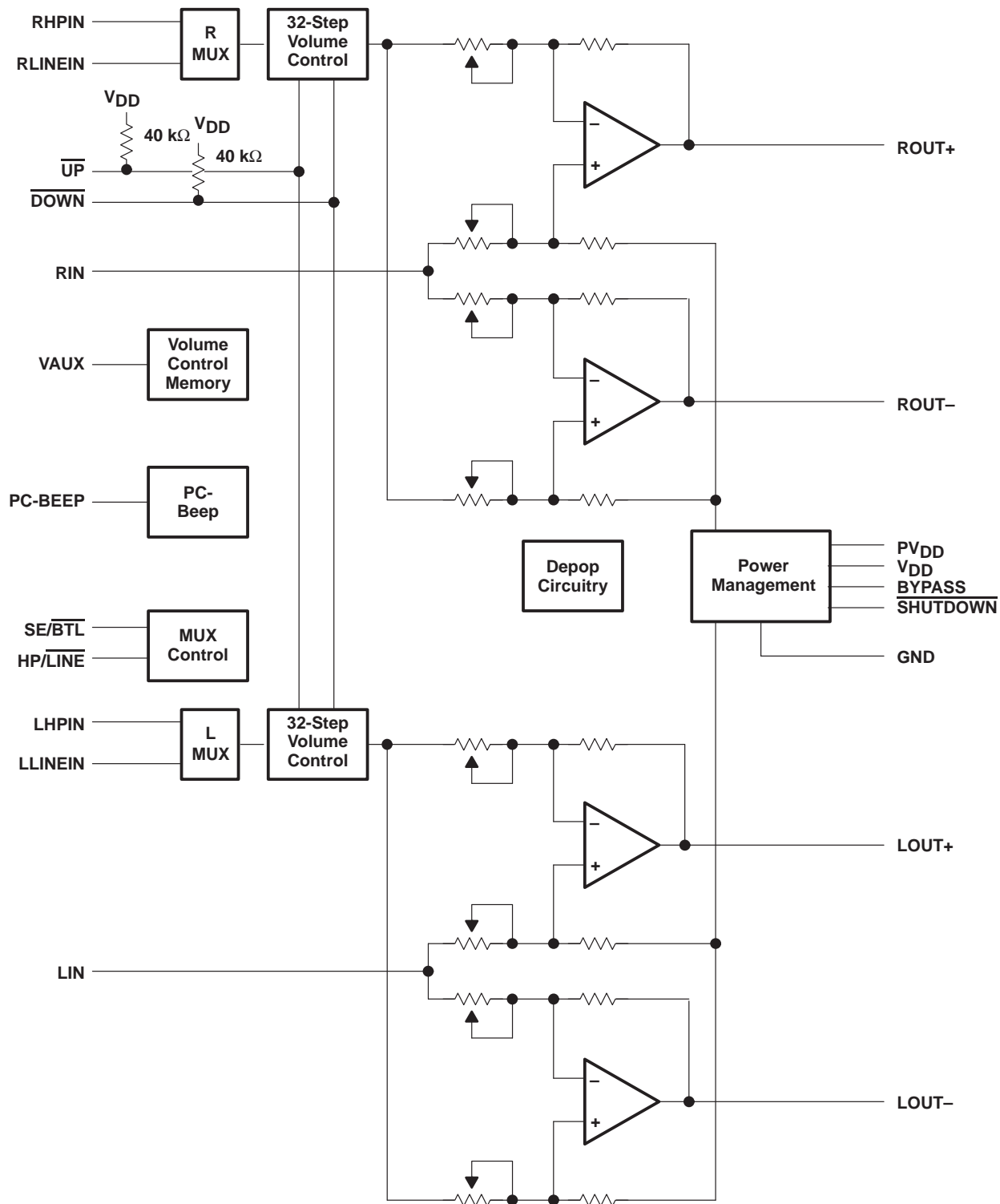

TPA0252
STEREO 2-W AUDIO POWER AMPLIFIER
WITH DIGITAL VOLUME CONTROL

SLOS288 – JUNE 2000

AVAILABLE OPTIONS

T_A	PACKAGED DEVICE
	TSSOP† (PWP)
–40°C to 85°C	TPA0252PWP

† The PWP package is available taped and reeled. To order a taped and reeled part, add the suffix R to the part number (e.g., TPA0252PWPR).

Terminal Functions

TERMINAL NAME	NO.	I/O	DESCRIPTION
BYPASS	7		Tap to voltage divider for internal mid-supply bias generator
CLK	6	I	If a 47-nF capacitor is attached, the TPA0252 generates an internal clock. An external clock can override the internal clock input to this terminal.
$\overline{\text{DOWN}}$	5	I	A momentary pulse on this terminal decreases the volume level by 2 dB. Holding the terminal low for a period of time will step the amplifier through the volume levels at a rate determined by the capacitor on the CLK terminal.
GND	12, 24		Ground connection for circuitry. Connected to thermal pad
HP/ $\overline{\text{LINE}}$	14	I	Input MUX control. When terminal is high, the LHPIN and RHPIN inputs are selected. When terminal is low, LLINEIN and RLINEIN inputs are selected.
LHPIN	19	I	Left-channel headphone input, selected when HP/ $\overline{\text{LINE}}$ is held high
LIN	21	I	Common left input for fully differential input. AC ground for single-ended inputs
LLINEIN	20	I	Left-channel line negative input, selected when HP/ $\overline{\text{LINE}}$ is held low
LOUT+	23	O	Left-channel positive output in $\overline{\text{BTL}}$ mode and positive in SE mode
LOUT–	1	O	Left-channel negative output in $\overline{\text{BTL}}$ mode and high impedance in SE mode
PC-BEEP	10	I	The input for PC beep mode. PC-BEEP is enabled when a > 1-V (peak-to-peak) square wave is input to PC-BEEP.
PVDD	3, 8	I	Power supply for output stage
RHPIN	17	I	Right channel headphone input, selected when HP/ $\overline{\text{LINE}}$ is held high
RIN	15	I	Common right input for fully differential input. AC ground for single-ended inputs
RLINEIN	16	I	Right-channel line input, selected when HP/ $\overline{\text{LINE}}$ is held low
ROUT+	13	O	Right-channel positive output in $\overline{\text{BTL}}$ mode and positive in SE mode
ROUT–	11	O	Right-channel negative output in $\overline{\text{BTL}}$ mode and high impedance in SE mode
SE/ $\overline{\text{BTL}}$	22	I	Output MUX control input. When this terminal is held high SE outputs are selected. When this terminal is held low BTL outputs are selected.
$\overline{\text{SHUTDOWN}}$	2	I	When held low, this terminal places the entire device, except PC-BEEP detect circuitry, in shutdown mode.
$\overline{\text{UP}}$	4	I	A momentary pulse on this terminal increases the volume level by 2 dB. Holding the terminal low for a period of time will step the amplifier through the volume levels at a rate determined by the capacitor on the CLK terminal.
VAUX	9	I	Volume control memory supply. Connect to system auxiliary that stays active when device is powered down.
VDD	18	I	Analog V _{DD} input supply. This terminal needs to be isolated from PV _{DD} to achieve highest performance.



TPA0252
STEREO 2-W AUDIO POWER AMPLIFIER
WITH DIGITAL VOLUME CONTROL

SLOS288 – JUNE 2000

absolute maximum ratings over operating free-air temperature range (unless otherwise noted)†

Supply voltage, V_{DD}	6 V
Input voltage, V_I	-0.3 V to $V_{DD} + 0.3$ V
Continuous total power dissipation	internally limited (see Dissipation Rating Table)
Operating free-air temperature range, T_A	-40°C to 85°C
Operating junction temperature range, T_J	-40°C to 150°C
Storage temperature range, T_{stg}	-65°C to 150°C
Lead temperature 1,6 mm (1/16 inch) from case for 10 seconds	260°C

† Stresses beyond those listed under “absolute maximum ratings” may cause permanent damage to the device. These are stress ratings only, and functional operation of the device at these or any other conditions beyond those indicated under “recommended operating conditions” is not implied. Exposure to absolute-maximum-rated conditions for extended periods may affect device reliability.

DISSIPATION RATING TABLE

PACKAGE	$T_A \leq 25^\circ\text{C}$	DERATING FACTOR	$T_A = 70^\circ\text{C}$	$T_A = 85^\circ\text{C}$
PWP	2.7 W‡	21.8 mW/°C	1.7 W	1.4 W

‡ See the Texas Instruments document, *PowerPAD™ Thermally Enhanced Package Application Report* (literature number SLMA002), for more information on the PowerPAD™ package. The thermal data was measured on a PCB layout based on the information in the section entitled *Texas Instruments Recommended Board for PowerPAD™* on page 33 of the before mentioned document.

recommended operating conditions

		MIN	MAX	UNIT
Supply voltage, V_{DD}		4.5	5.5	V
Volume control memory supply voltage, V_{AUX}		3	5.5	V
High-level input voltage, V_{IH}	CLK	4.5		V
	SE/BTL, HP/LINE, UP, DOWN	4		
	SHUTDOWN	2		
Low-level input voltage, V_{IL}	SE/BTL, HP/LINE		3	V
	SHUTDOWN		0.8	
	UP, DOWN, CLK		0.5	
Operating free-air temperature, T_A		-40	85	°C



TPA0252
STEREO 2-W AUDIO POWER AMPLIFIER
WITH DIGITAL VOLUME CONTROL

SLOS288 – JUNE 2000

electrical characteristics at specified free-air temperature, $V_{DD} = 5\text{ V}$, $T_A = 25^\circ\text{C}$ (unless otherwise noted)

PARAMETER		TEST CONDITIONS	MIN	TYP	MAX	UNIT
V _{OS}	Output offset voltage (measured differentially)	$V_I = 0$, $A_V = 2$			25	mV
	Supply ripple rejection ratio	$V_{DD} = 4.9\text{ V to } 5.1\text{ V}$		67		dB
I _{IHL}	High-level input current	$V_{DD} = 5.5\text{ V}$, $V_I = V_{DD}$			1	μA
I _{IL}	Low-level input current	$V_{DD} = 5.5\text{ V}$, $V_I = 0\text{ V}$			1	μA
					125	μA
I _{DD}	Supply current	BTL mode		9	15	mA
		SE mode		4.5	7.5	
I _{DD(SD)}	Supply current, shutdown mode			150	300	μA
I _{DD(VAUX)}	Supply current, VAUX pin (see Figure 29)	$V_{AUX} = 5\text{ V}$, $V_{DD} = 0\text{ V}$		0.7		nA

operating characteristics, $V_{DD} = 5\text{ V}$, $T_A = 25^\circ\text{C}$, $R_L = 4\ \Omega$, Gain = 20 dB, BTL mode (unless otherwise noted)

PARAMETER		TEST CONDITIONS		MIN	TYP	MAX	UNIT
P _O	Output power	THD = 1%,	f = 1 kHz		2		W
THD + N	Total harmonic distortion plus noise	P _O = 1 W,	f = 20 Hz to 15 kHz		0.3%		
B _{OM}	Maximum output power bandwidth	THD = 5%			>15		kHz
k _{SVR}	Supply ripple rejection ratio	f = 1 kHz, C _B = 0.47 μF	BTL mode		65		dB
			SE mode, Gain = 14 dB		60		
V _n	Noise output voltage	C _B = 0.47 μF , f = 20 Hz to 20 kHz	BTL mode, Gain = 6 dB		17		μV_{RMS}
			SE mode, Gain = 0 dB		44		

TYPICAL CHARACTERISTICS

Table of Graphs

			FIGURE
THD+N	Total harmonic distortion plus noise	vs Output power	1, 4, 6, 8, 10
		vs Gain	2
		vs Frequency	3, 5, 7, 9, 11, 12
V _n	Output noise voltage	vs Frequency	13
	Supply ripple rejection ratio	vs Frequency	14, 15
	Crosstalk	vs Frequency	16, 17, 18
	Shutdown attenuation	vs Frequency	19
SNR	Signal-to-noise ratio	vs Frequency	20
	Closed loop response		21, 22
P _O	Output power	vs Load resistance	23, 24
P _D	Power dissipation	vs Output power	25, 26
		vs Ambient temperature	27
R _I	Input resistance	vs Gain	28
I _{DD(VAUX)}	Supply current	vs V _{AUX}	29



TYPICAL CHARACTERISTICS

TOTAL HARMONIC DISTORTION PLUS NOISE
 vs
 OUTPUT POWER

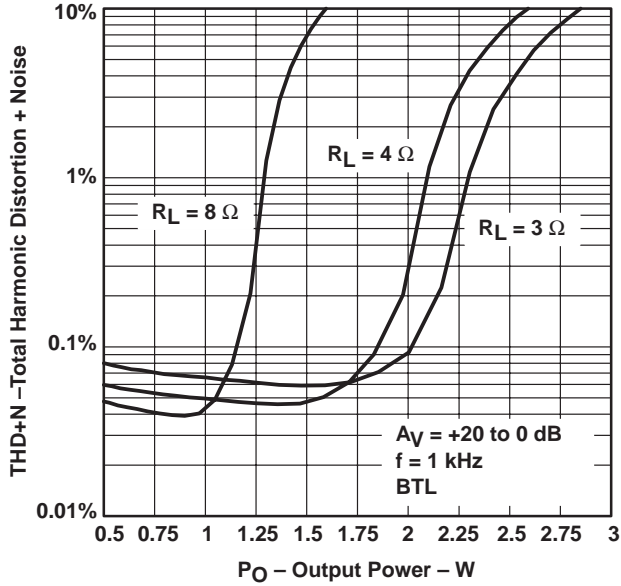

Figure 1

TOTAL HARMONIC DISTORTION PLUS NOISE
 vs
 GAIN

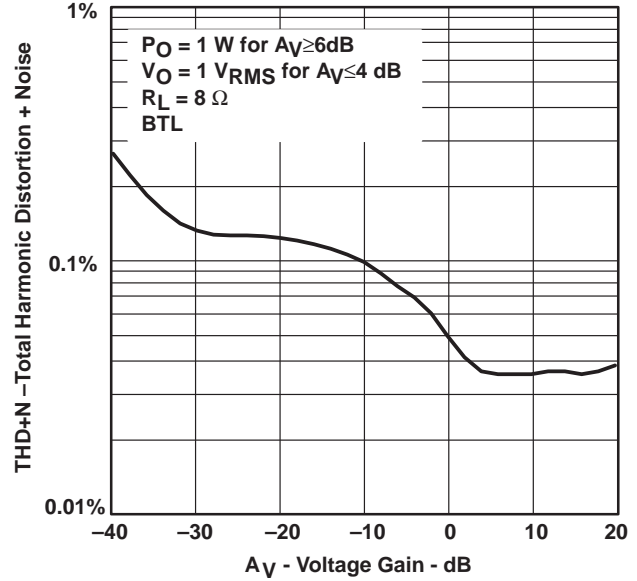

Figure 2

TOTAL HARMONIC DISTORTION PLUS NOISE
 vs
 FREQUENCY

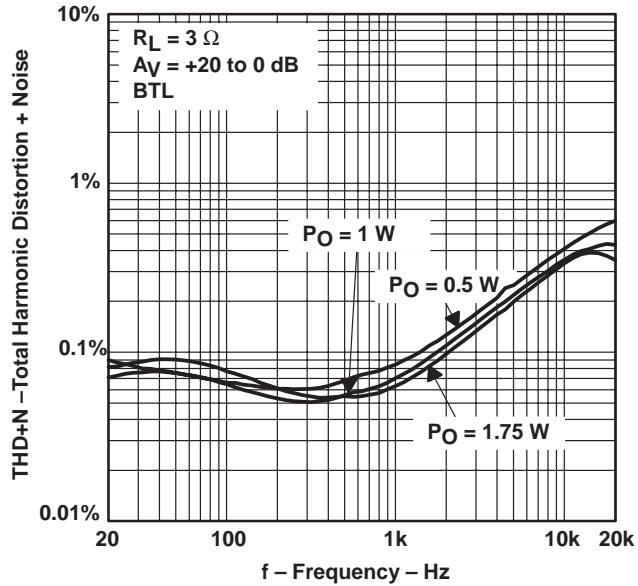

Figure 3

TOTAL HARMONIC DISTORTION PLUS NOISE
 vs
 OUTPUT POWER

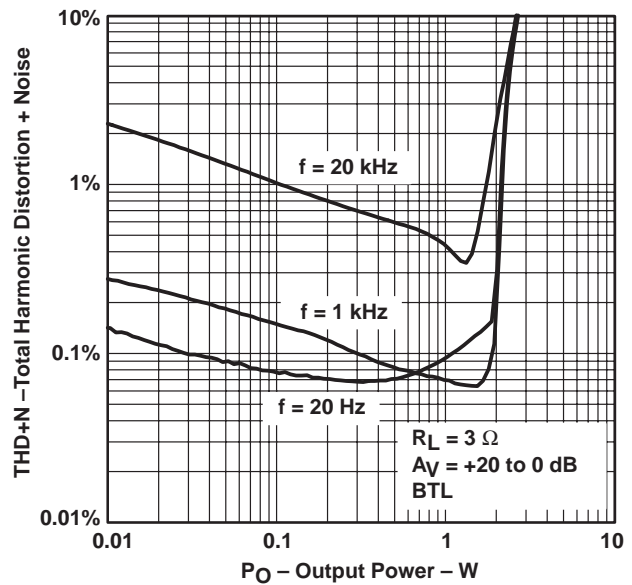

Figure 4

TYPICAL CHARACTERISTICS

TOTAL HARMONIC DISTORTION PLUS NOISE
 vs
 FREQUENCY

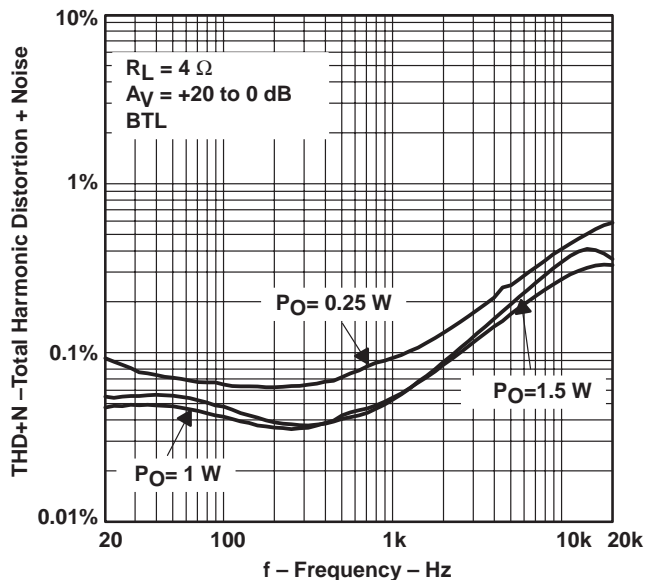

Figure 5

TOTAL HARMONIC DISTORTION PLUS NOISE
 vs
 OUTPUT POWER

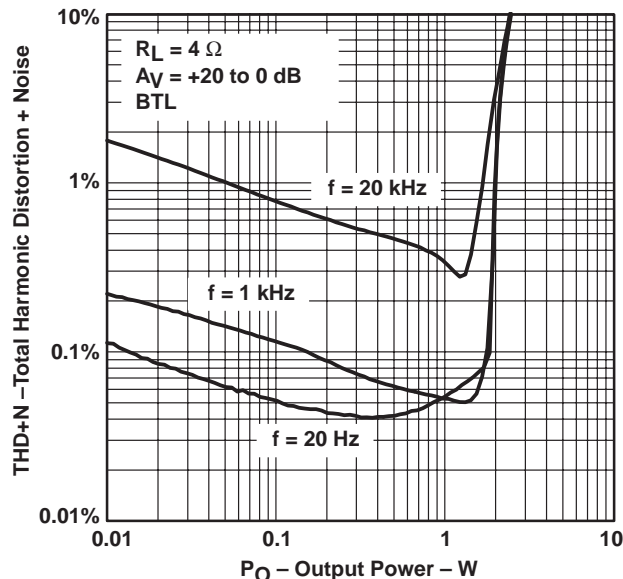

Figure 6

TOTAL HARMONIC DISTORTION PLUS NOISE
 vs
 FREQUENCY

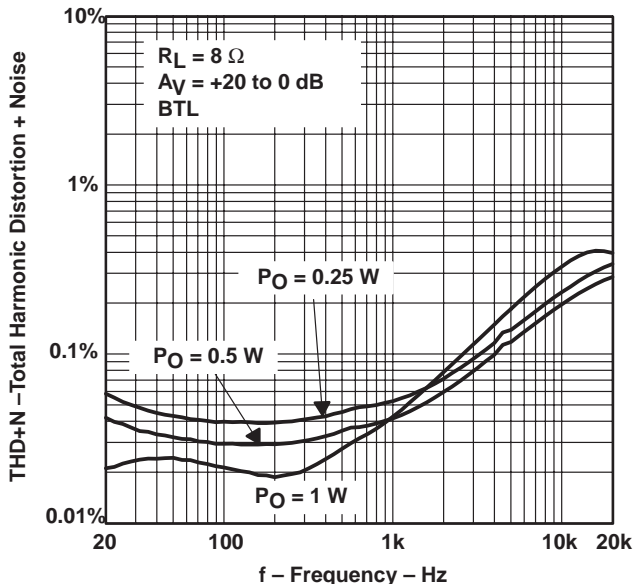

Figure 7

TOTAL HARMONIC DISTORTION PLUS NOISE
 vs
 OUTPUT POWER

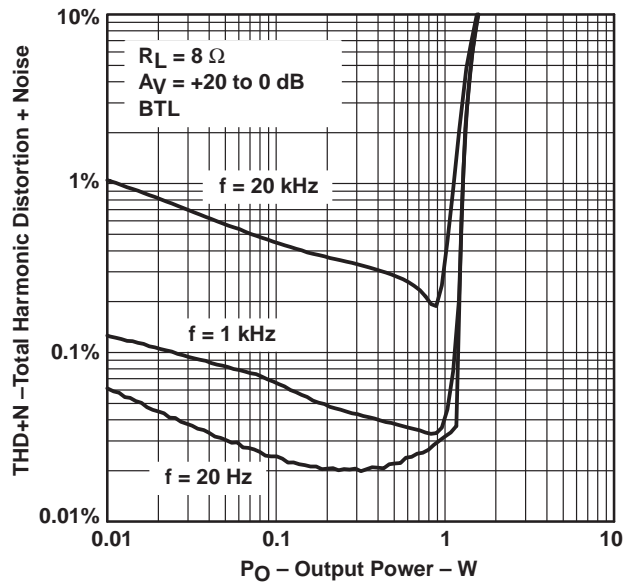

Figure 8

TYPICAL CHARACTERISTICS

TOTAL HARMONIC DISTORTION PLUS NOISE
 vs
 FREQUENCY

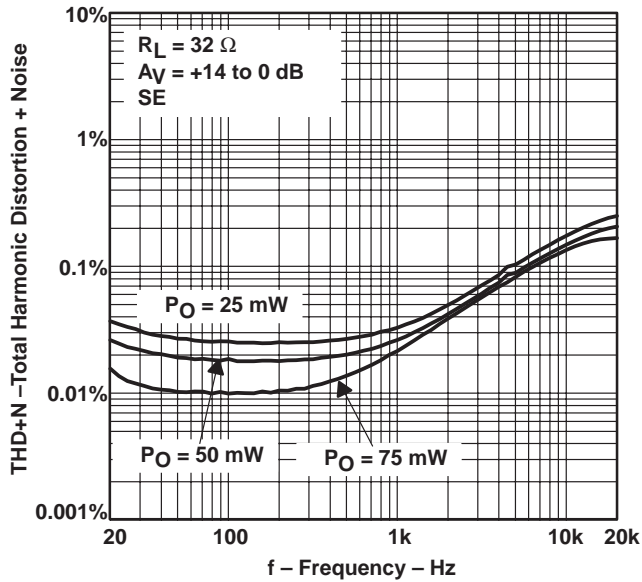

Figure 9

TOTAL HARMONIC DISTORTION PLUS NOISE
 vs
 OUTPUT POWER

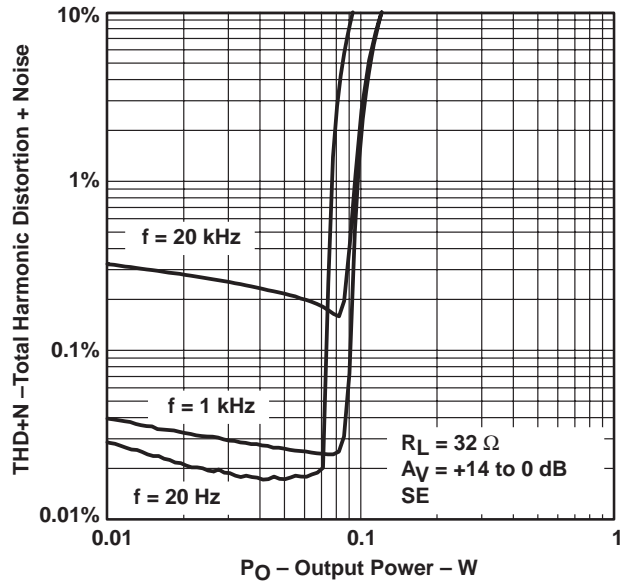

Figure 10

TOTAL HARMONIC DISTORTION PLUS NOISE
 vs
 FREQUENCY

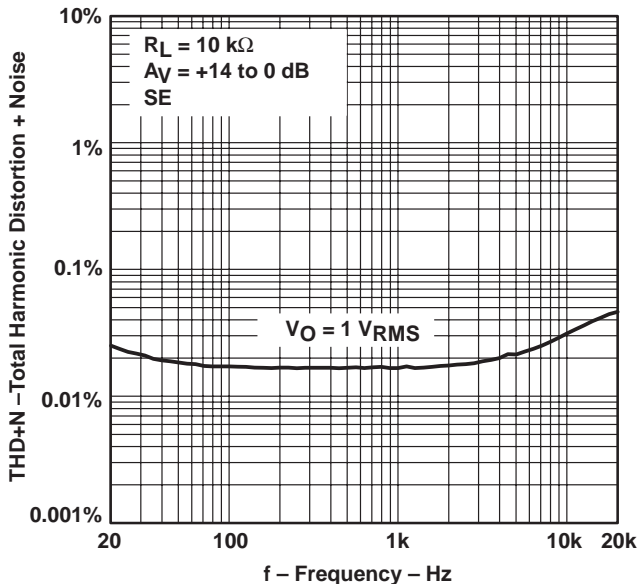

Figure 11

TOTAL HARMONIC DISTORTION PLUS NOISE
 vs
 FREQUENCY

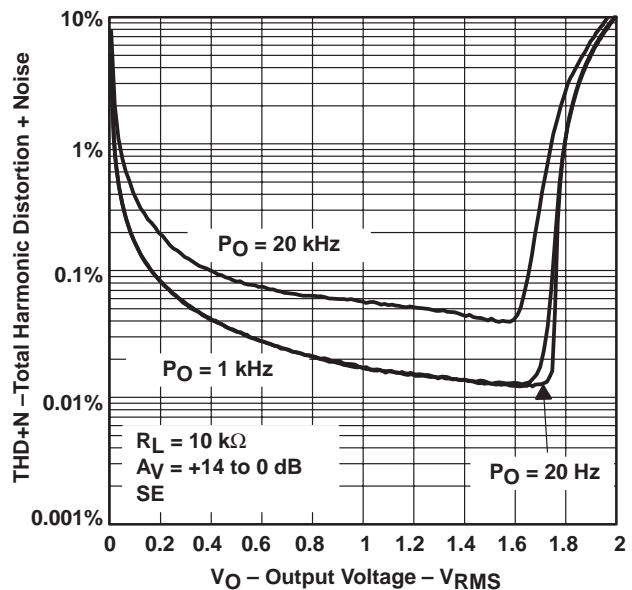

Figure 12

TYPICAL CHARACTERISTICS

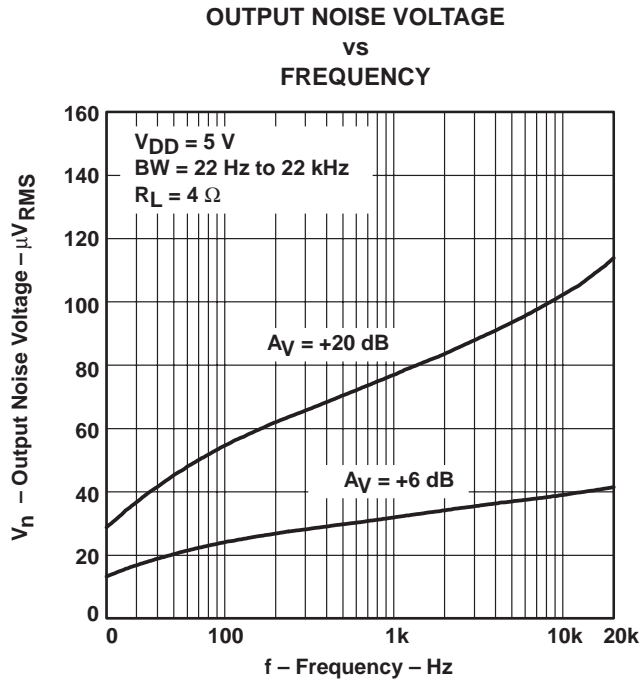

Figure 13

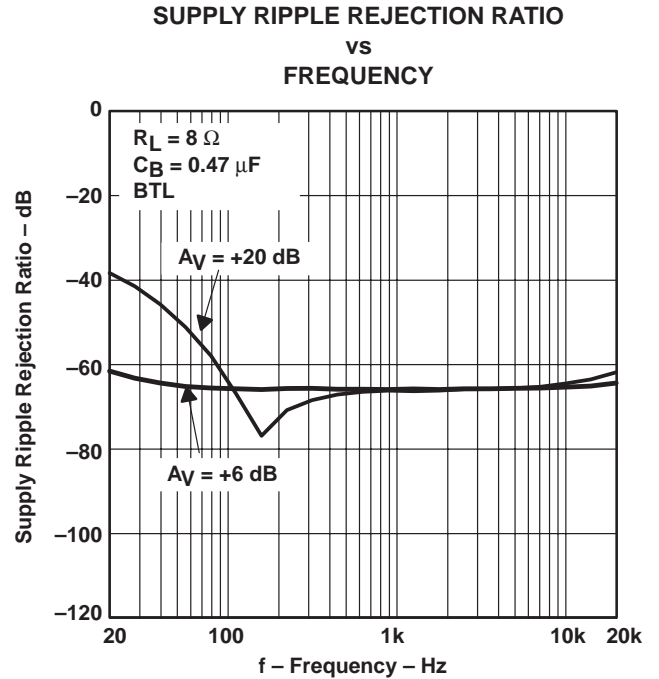

Figure 14

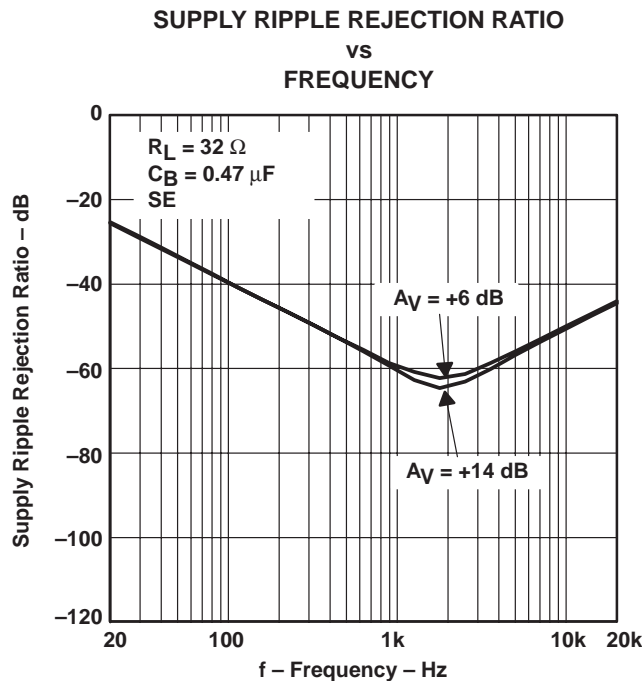

Figure 15

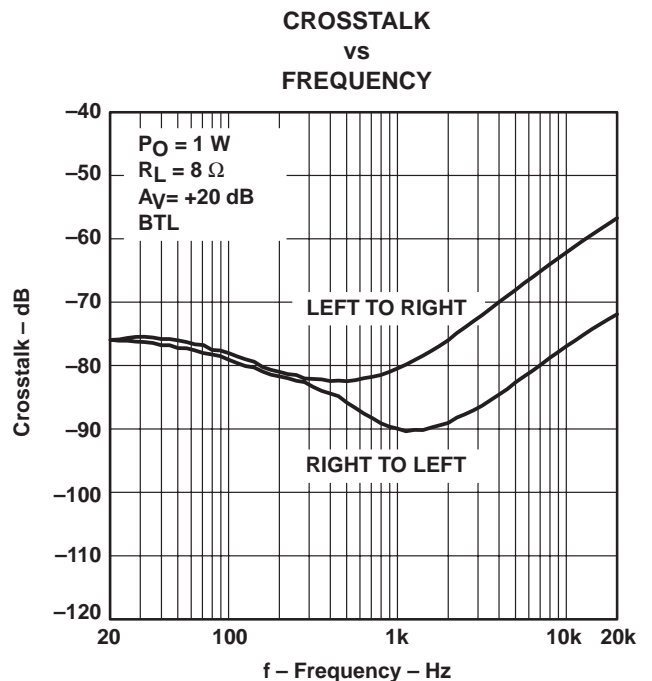

Figure 16

TYPICAL CHARACTERISTICS

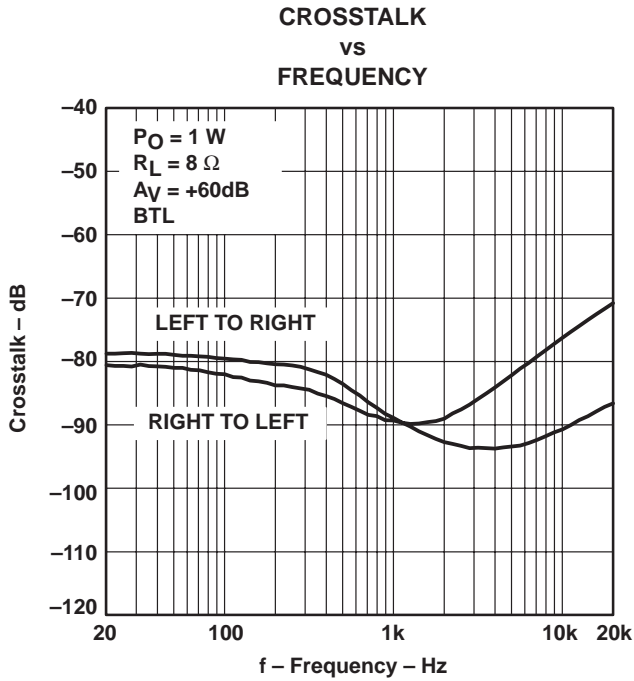

Figure 17

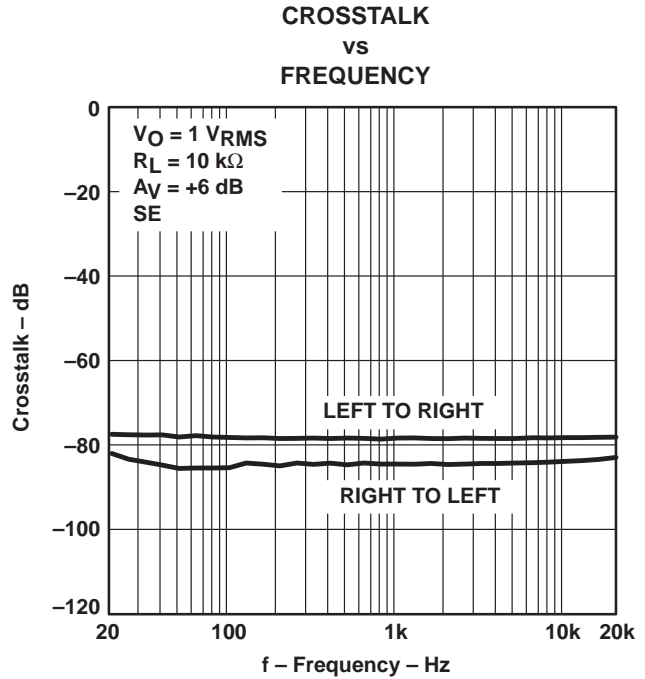

Figure 18

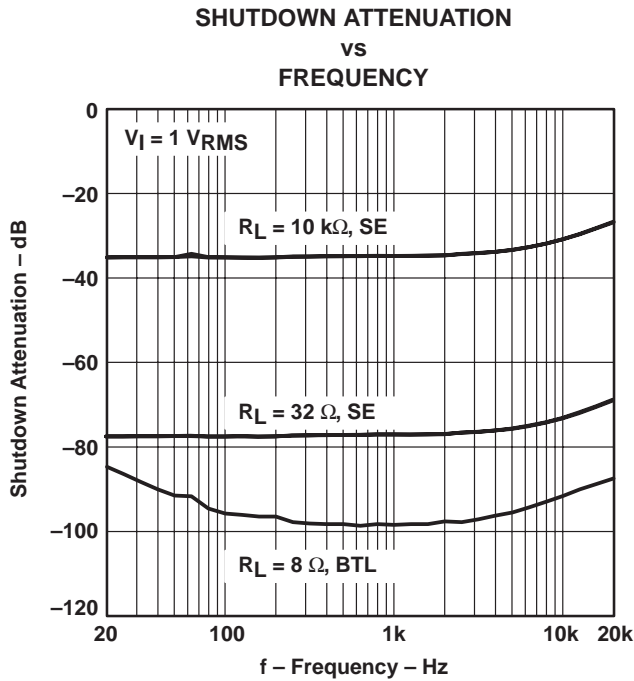

Figure 19

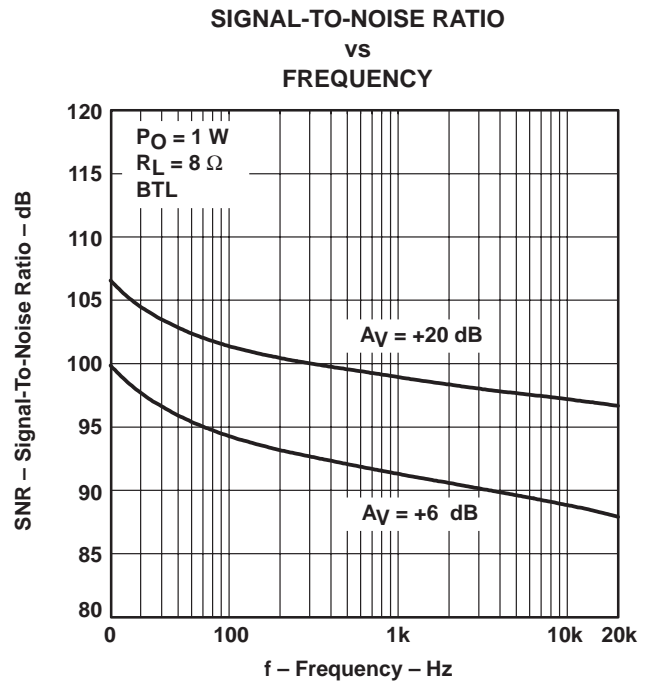

Figure 20

TYPICAL CHARACTERISTICS

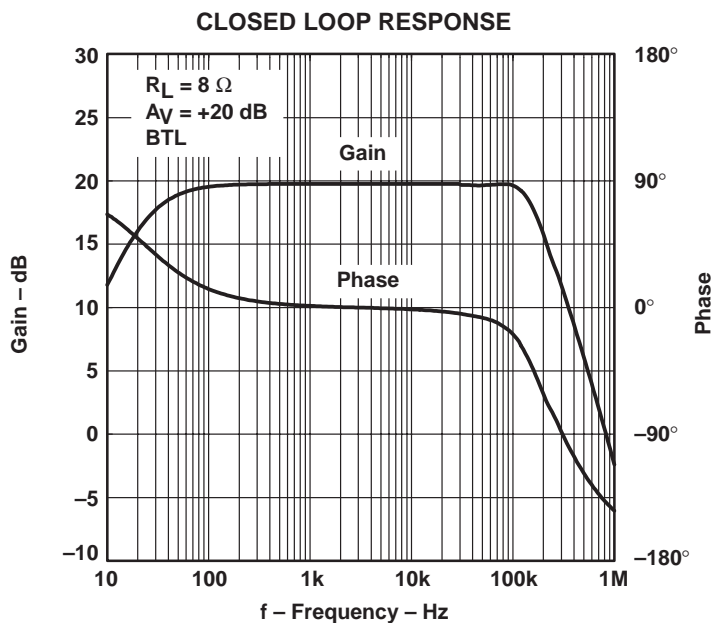

Figure 21

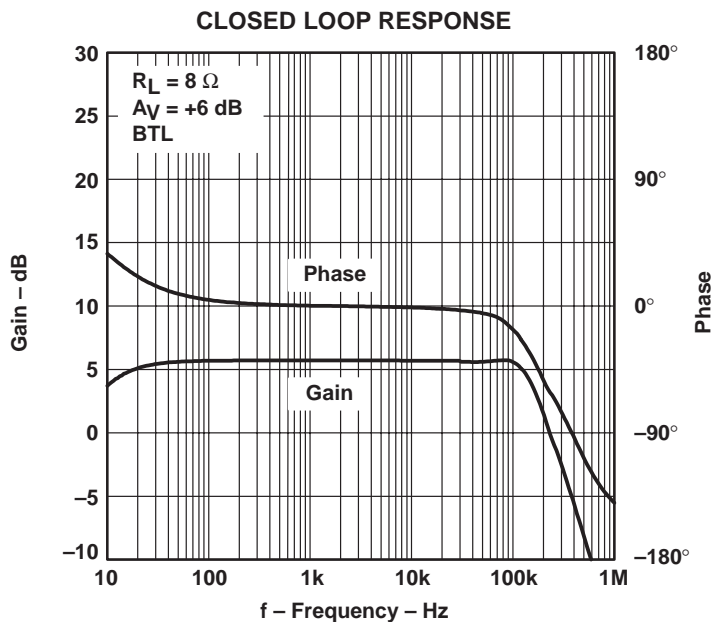

Figure 22

TYPICAL CHARACTERISTICS

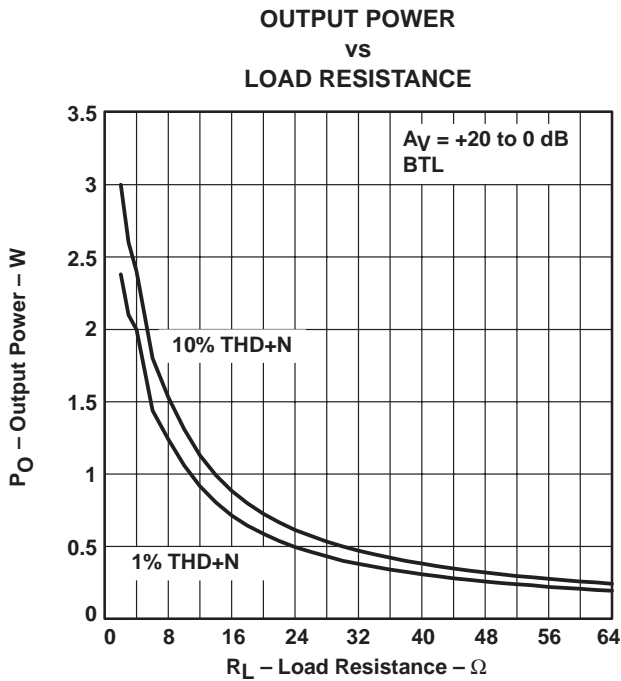

Figure 23

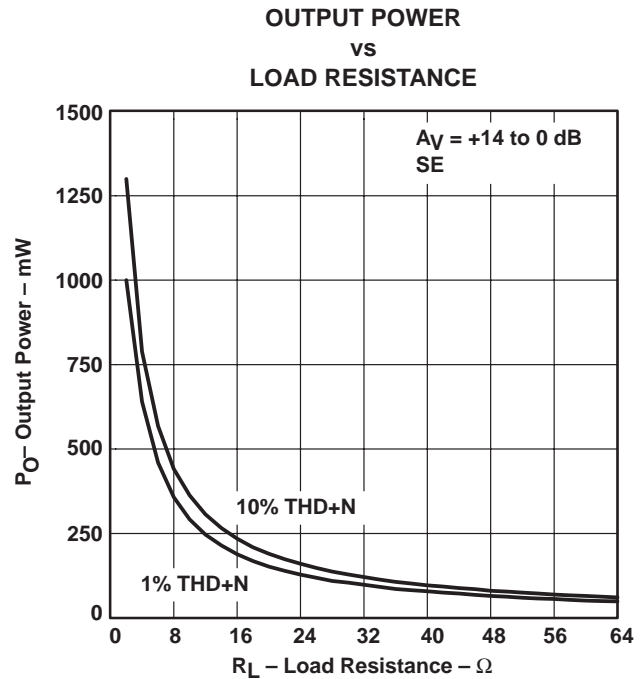

Figure 24

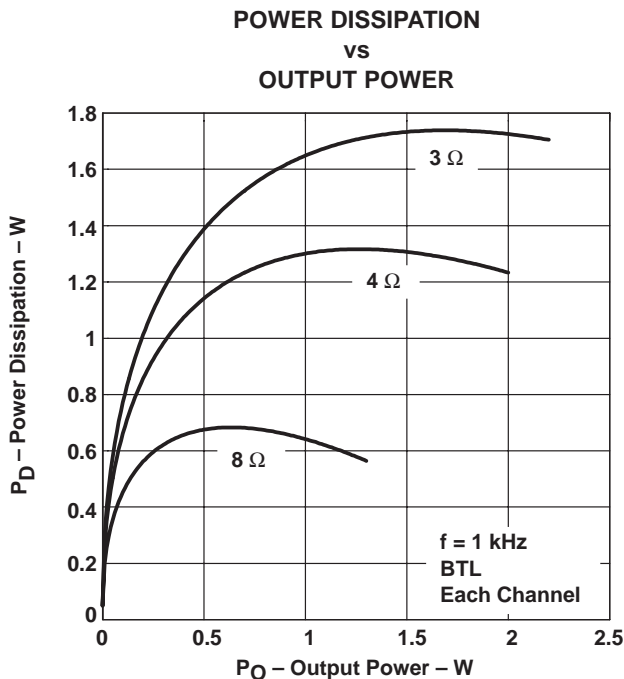

Figure 25

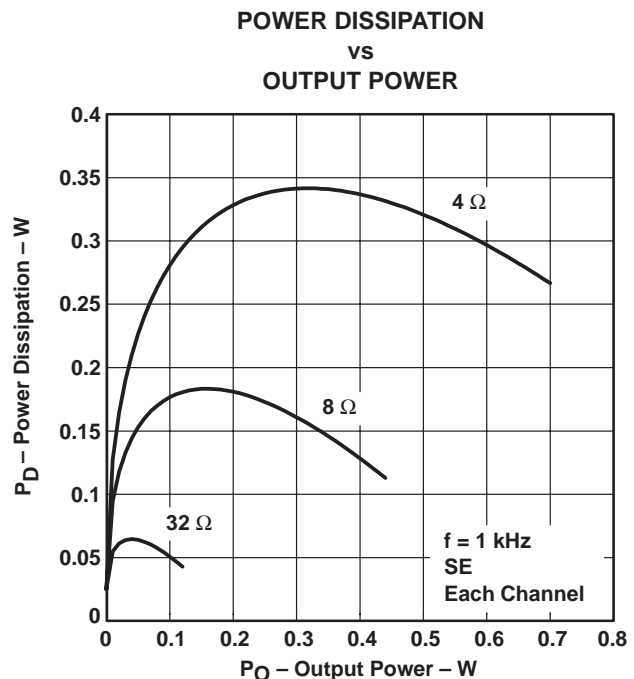

Figure 26

TYPICAL CHARACTERISTICS

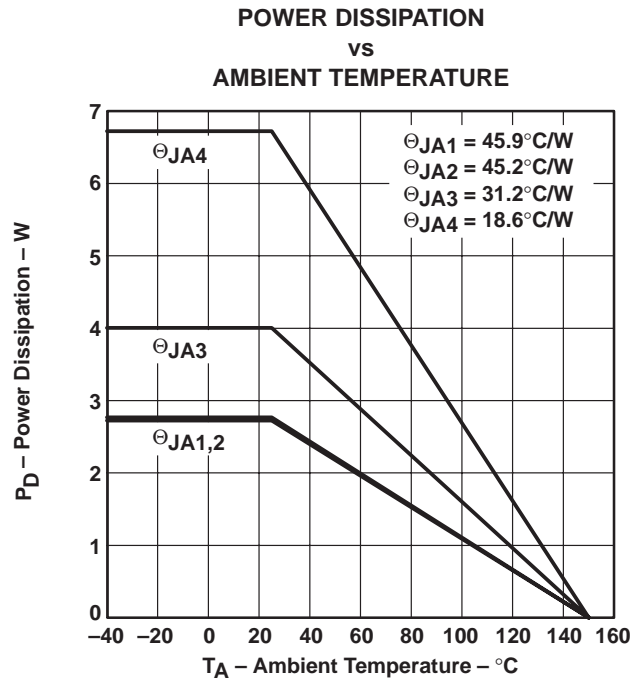

Figure 27

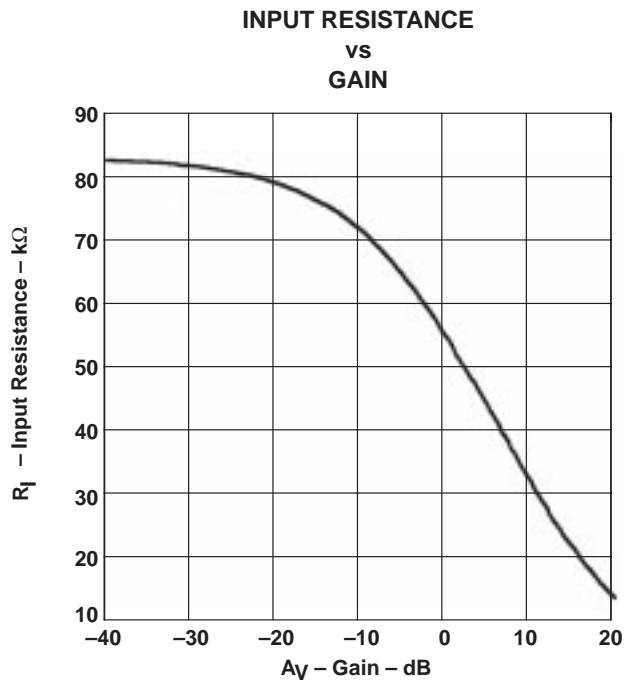

Figure 28

TYPICAL CHARACTERISTICS

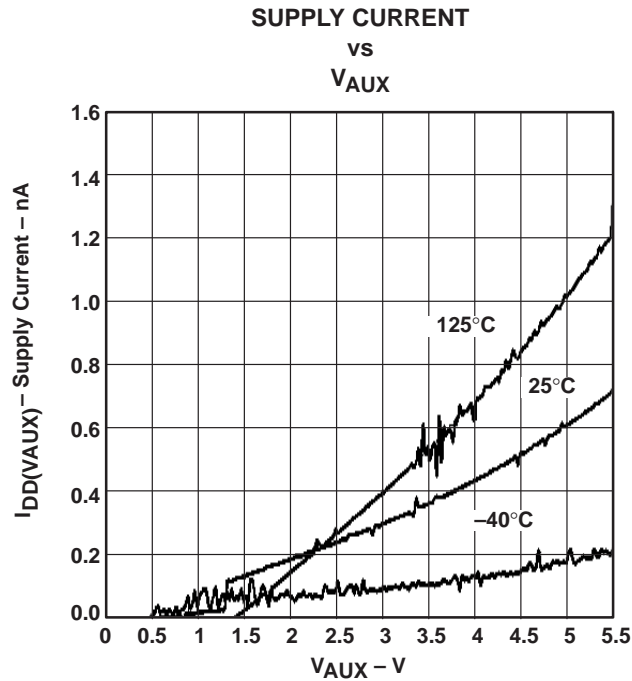

Figure 29

APPLICATION INFORMATION

selection of components

Figure 30 and Figure 31 are schematic diagrams of typical notebook computer application circuits.

TPA0252 STEREO 2-W AUDIO POWER AMPLIFIER WITH DIGITAL VOLUME CONTROL

SLOS288 – JUNE 2000

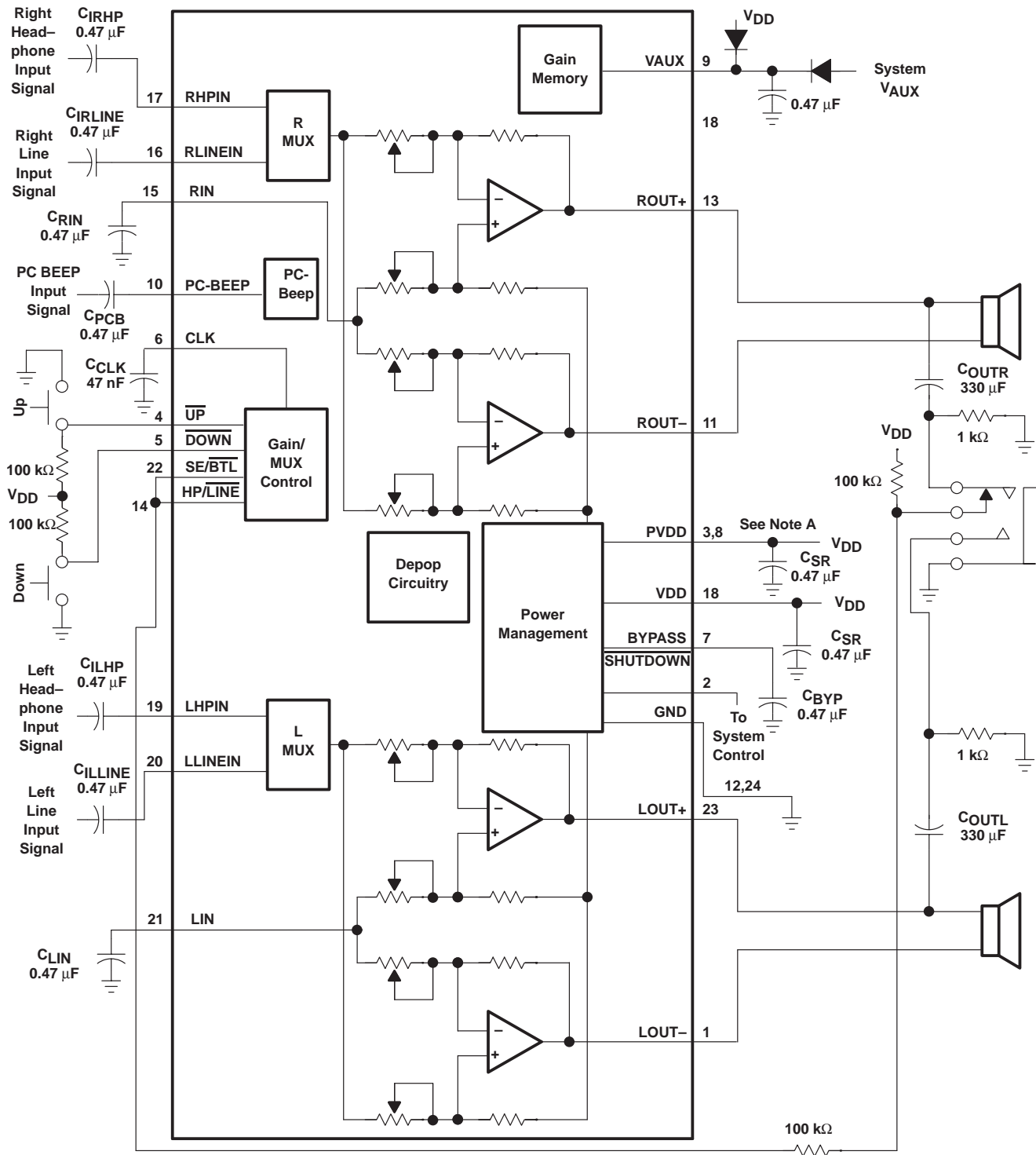

NOTE A: A 0.47 μF ceramic capacitor should be placed as close as possible to the IC. For filtering lower-frequency noise signals, a larger electrolytic capacitor of 10 μF or greater should be placed near the audio power amplifier.

Figure 30. Typical TPA0252 Application Circuit Using Single-Ended Inputs and Input MUX

TPA0252
STEREO 2-W AUDIO POWER AMPLIFIER
WITH DIGITAL VOLUME CONTROL

SLOS288 – JUNE 2000

APPLICATION INFORMATION

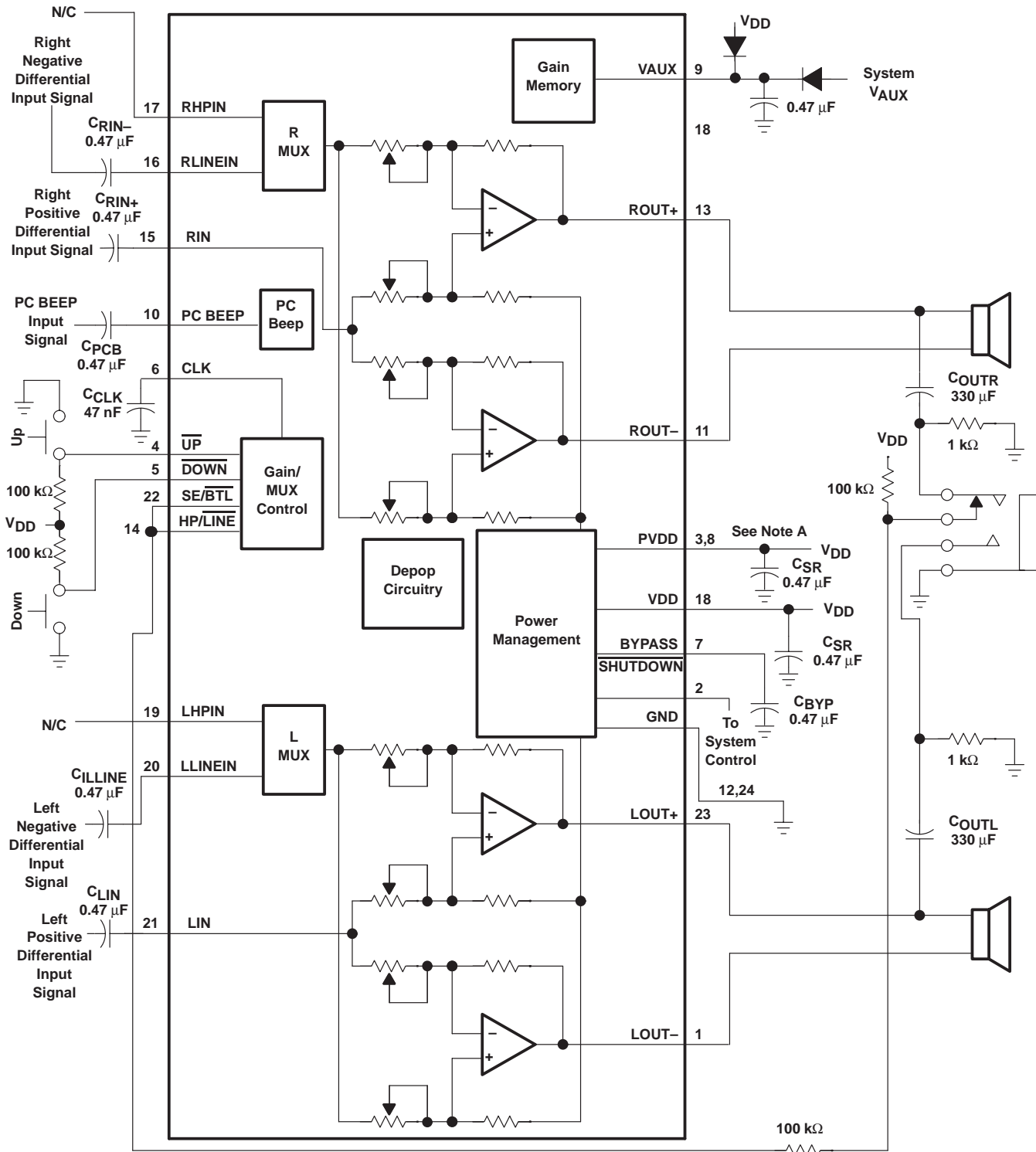

NOTE A: A 0.47 μF ceramic capacitor should be placed as close as possible to the IC. For filtering lower-frequency noise signals, a larger electrolytic capacitor of 10 μF or greater should be placed near the audio power amplifier.

Figure 31. Typical TPA0252 Application Circuit Using Differential Inputs



APPLICATION INFORMATION

up/down volume control

changing volume

The default volume is set at -10 dB for BTL mode and -16 dB for SE mode. The volume is increased in 2-dB steps by pulling the voltage low on terminal $\overline{\text{UP}}$. The volume is decreased in 2-dB steps by pulling the voltage low on terminal $\overline{\text{DOWN}}$. If $\overline{\text{UP}}$ and $\overline{\text{DOWN}}$ are held low at the same time, the device is muted, and the volume returns to its previous setting after $\overline{\text{UP}}$ and $\overline{\text{DOWN}}$ are pulled high.

Table 1. Volume Settings

Volume Control	
BTL (dB)	SE (dB)
20	14
18	12
16	10
14	8
12	6
10	4
8	2
6	0
4	-2
2	-4
0	-6
-2	-8
-4	-10
-6	-12
-8	-14
-10	-16
-12	-18
-14	-20
-16	-22
-18	-24
-20	-26
-22	-28
-24	-30
-26	-32
-28	-34
-30	-36
-32	-38
-34	-40
-36	-42
-38	-44
-40	-46
Mute	-85

Up

Down

APPLICATION INFORMATION

changing volume when using the internal clock

If using the internal clock, the maximum clock frequency is 500Hz and the recommended frequency is 100 Hz using a 47-nF capacitor. The formula for calculating the clock frequency if using a cap to generate the clock is shown below.

$$f_{CLK} = \frac{4.7 \times 10^{-6}}{C_{CLK}} \tag{1}$$

Note: This equation is an approximation, f_{CLK} will vary.

When the desired line is pulled low for four clock cycles, the volume will increment by one step, followed by a short delay. This delay will decrease the longer the line is held low, eventually reaching a delay of zero. The delay allows the user to pull the \overline{UP} or \overline{DOWN} terminal low once for one volume change, or hold down to ramp several volume changes. The delay is optimally configured for push button volume control.

Holding either \overline{UP} or \overline{DOWN} low continuously causes the volume to change at an exponentially increasing rate. When $f_{CLK} = 100$ Hz, the first change in the volume occurs approximately 40 ms after either pin is initially pulled low. If the pin stays low for approximately 400 more ms, the volume changes again. The next change occurs 200 ms after this change. The fourth change occurs 120 ms after the third change. The fifth volume change occurs 80 ms after the fourth change. Thereafter, the volume changes at 1/4 the rate of the clock (every 40 ms).

Each cycle is registered on the rising clock edge and the volume is changed after the rising edge.

The figure below shows increasing volume using \overline{UP} , however, the volume is decreased using \overline{DOWN} with the same timing.

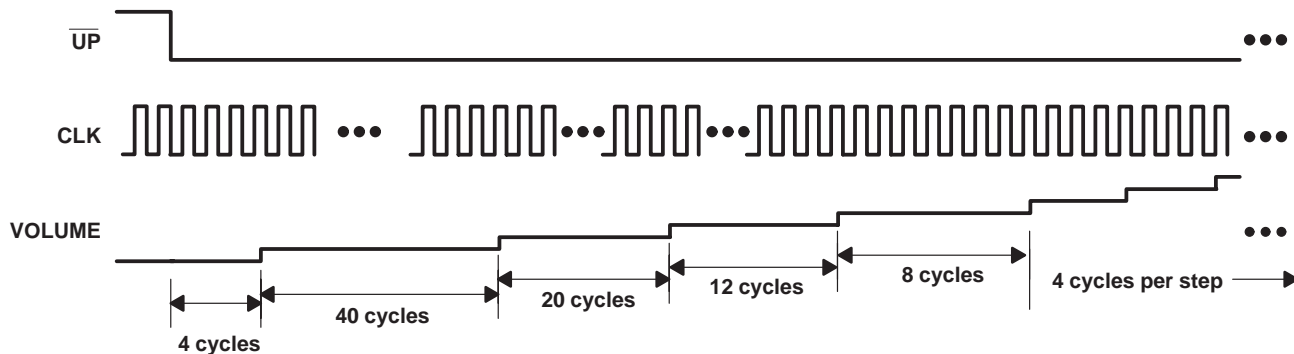

Figure 32. Internal Clock Timing Diagram

APPLICATION INFORMATION

changing volume when using the external clock (microprocessor mode)

The user may remove the capacitor and run the external clock directly into the clock pin to override the internal clock generator. The maximum clock frequency is 10 kHz if using an external clock; however, it is recommended that the clock frequency be less than 200 Hz in normal operation so the gain will not change too quickly causing a pop at the output. A 5-V clock must be used because the trip levels are 0.5 V and 4.5 V. The clock needs to have 50% duty cycle. The recommended way of adjusting the volume is to use a gated clock and hold \overline{UP} or \overline{DOWN} low and cycle the clock pin four times to adjust the volume. The volume change is clocked in at the rising edge. CLK should be held low when not changing volume. No delay is added when using an external clock, so it is very important to only input four clock cycles per volume change. Any additional clock cycles per volume change will be added to the next volume change. For example, if five clock cycles are input while \overline{UP} is held low the first volume change, the volume change will occur after the third clock cycle the next time \overline{UP} is held low. The figure below shows how volume increases with \overline{UP} when an external clock is used. The sample and hold times for \overline{UP} and \overline{DOWN} are 100 ns. The same timing applies if using an external clock and decreasing the volume with \overline{DOWN} .

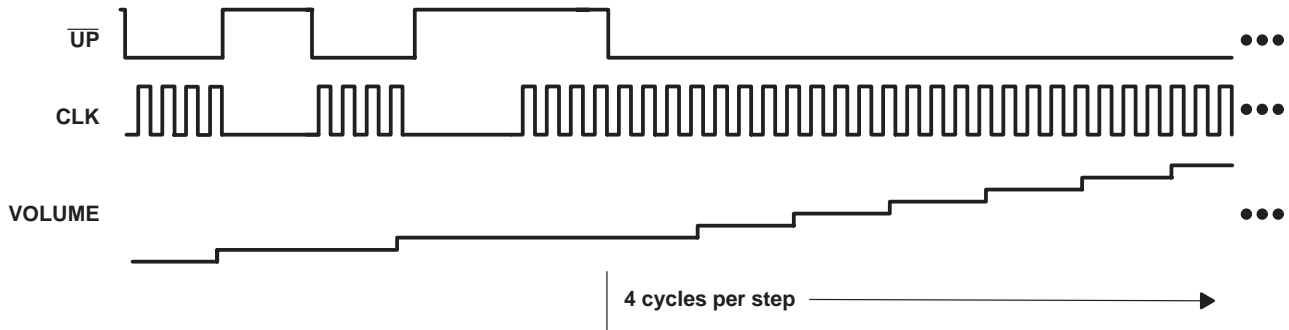

Figure 33. External Clock (4 cycles per volume change)

V_{AUX}

V_{AUX} is used to keep power to the volume control memory. As long as the voltage at the V_{AUX} pin is greater than 3 V, the device will remember what volume setting it was in, even when shut-down or powered down. The amplifier will then return to that volume setting after being powered up. If V_{AUX} is pulled low, the device will reset to a volume setting of -10 dB in BTL and -16 dB in SE mode. If V_{AUX} is pulled below ground, the device could be damaged. Even if V_{AUX} is connected to just one voltage, it should be connected through a diode so V_{AUX} is not pulled below ground. The recommended circuit to keep V_{AUX} high when power down is shown below.

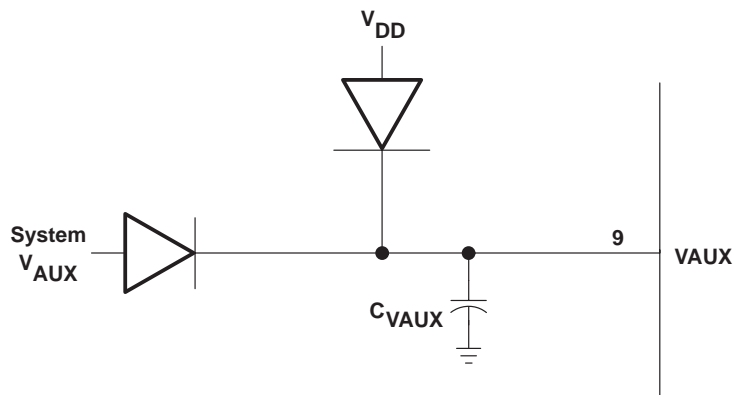

Figure 34. Recommended System V_{AUX} Circuit

TPA0252

STEREO 2-W AUDIO POWER AMPLIFIER WITH DIGITAL VOLUME CONTROL

SLOS288 – JUNE 2000

V_{AUX} (continued)

The diodes in Figure 34 need to have a low threshold voltage and low leakage current. This circuit allows V_{AUX} to remain high even when V_{DD} and system V_{AUX} are removed. The formula for calculating how long the volume will be remembered if V_{DD} and system V_{AUX} is removed or pulled low is shown below. The diode used in the example has a forward voltage, V_F of 0.7 V and 25 nA of leakage current, I_R.

$$t_{\text{decay}} = C_{\text{VAUX}} \times ((V_{\text{DD}} \text{ or system } V_{\text{AUX}}) - V_{\text{F}} - V_{\text{AUXmin}}) / (2 \times I_{\text{R}} + I_{\text{DD}}(\text{VAUX}))$$

$$t_{\text{decay}} = 0.47 \mu\text{F} \times (5\text{V} - 0.7\text{V} - 3\text{V}) / (25 \text{ nA} \times 2 + 0.7 \text{ nA})$$

$$t_{\text{decay}} = 12 \text{ seconds}$$

input resistance

Each gain setting is achieved by varying the input resistance of the amplifier, which can range from its smallest value to over 6 times that value. As a result, if a single capacitor is used in the input high pass filter, the –3 dB or cutoff frequency will also change by over 6 times. If an additional resistor is connected from the input pin of the amplifier to ground, as shown in the figure below, the variation of the cutoff frequency will be much reduced.

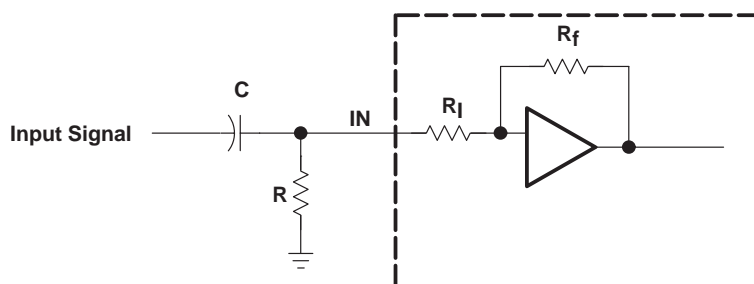

The input resistance at each gain setting is given in Figure 28.

The –3 dB frequency can be calculated using equation 2.

$$f_{-3 \text{ dB}} = \frac{1}{2\pi C(R \parallel R_i)} \tag{2}$$

If the filter must be more accurate, the value of the capacitor should be increased while value of the resistor to ground should be decreased. In addition, the order of the filter could be increased.

input capacitor, C₁

In the typical application an input capacitor, C₁, is required to allow the amplifier to bias the input signal to the proper dc level for optimum operation. In this case, C₁ and the input impedance of the amplifier, Z_I, form a high-pass filter with the corner frequency determined in equation 3.

APPLICATION INFORMATION

input capacitor, C_I (continued)

$$f_{c(\text{highpass})} = \frac{1}{2\pi Z_I C_I} \quad (3)$$

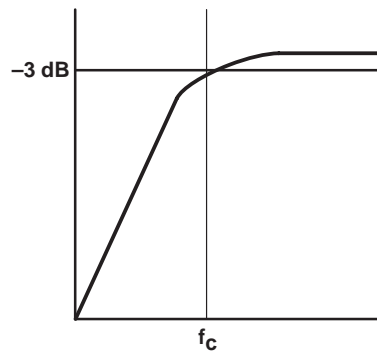

The value of C_I is important to consider as it directly affects the bass (low frequency) performance of the circuit. Consider the example where Z_I is 15 k Ω (from Figure 28) and the specification calls for a flat bass response down to 40 Hz. Equation 3 is reconfigured as equation 4.

$$C_I = \frac{1}{2\pi Z_I f_c} \quad (4)$$

In this example, C_I is 0.27 μF , so one would likely choose a value in the range of 0.27 μF to 1 μF . A further consideration for this capacitor is the leakage path from the input source through the input network (C_I) and the feedback network to the load. This leakage current creates a dc offset voltage at the input to the amplifier that reduces useful headroom, especially in high gain applications. For this reason a low-leakage tantalum or ceramic capacitor is the best choice. When polarized capacitors are used, the positive side of the capacitor should face the amplifier input in most applications as the dc level there is held at $V_{DD}/2$, which is likely higher than the source dc level. Note that it is important to confirm the capacitor polarity in the application.

power supply decoupling, C_S

The TPA0252 is a high-performance CMOS audio amplifier that requires adequate power supply decoupling to ensure the output total harmonic distortion (THD) is as low as possible. Power supply decoupling also prevents oscillations for long lead lengths between the amplifier and the speaker. The optimum decoupling is achieved by using two capacitors of different types that target different types of noise on the power supply leads. For higher frequency transients, spikes, or digital hash on the line, a good low equivalent-series-resistance (ESR) ceramic capacitor, typically 0.1 μF placed as close as possible to the device V_{DD} lead, works best. For filtering lower-frequency noise signals, a larger aluminum electrolytic capacitor of 10 μF or greater placed near the audio power amplifier is recommended.

midrail bypass capacitor, C_{BYP}

The midrail bypass capacitor, C_{BYP} , is the most critical capacitor and serves several important functions. During start-up or recovery from shutdown mode, C_{BYP} determines the rate at which the amplifier starts up. The second function is to reduce noise produced by the power supply caused by coupling into the output drive signal. This noise is from the midrail generation circuit internal to the amplifier, which appears as degraded PSRR and THD+N.

Bypass capacitor, C_{BYP} , values of 0.47 μF to 1 μF ceramic or tantalum low-ESR capacitors are recommended for the best THD and noise performance.

APPLICATION INFORMATION

output coupling capacitor, C_C

In the typical single-supply SE configuration, an output coupling capacitor (C_C) is required to block the dc bias at the output of the amplifier, thus preventing dc currents in the load. As with the input coupling capacitor, the output coupling capacitor and impedance of the load form a high-pass filter governed by equation 5.

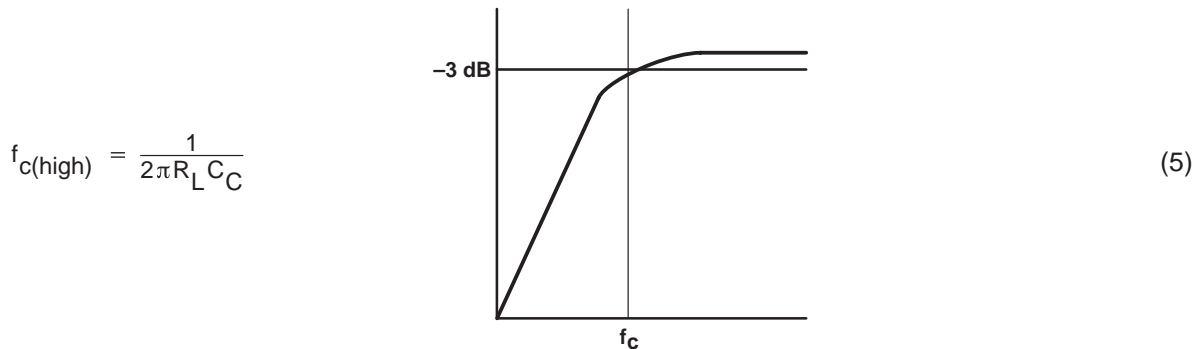

The main disadvantage, from a performance standpoint, is the load impedances are typically small, which drives the low-frequency corner higher degrading the bass response. Large values of C_C are required to pass low frequencies into the load. Consider the example where a C_C of 330 μF is chosen and loads vary from 3 Ω, 4 Ω, 8 Ω, 32 Ω, 10 kΩ, and 47 kΩ. Table 2 summarizes the frequency response characteristics of each configuration.

Table 2. Common Load Impedances vs Low Frequency Output Characteristics in SE Mode

R _L	C _C	LOWEST FREQUENCY
3 Ω	330 μF	161 Hz
4 Ω	330 μF	120 Hz
8 Ω	330 μF	60 Hz
32 Ω	330 μF	15 Hz
10,000 Ω	330 μF	0.05 Hz
47,000 Ω	330 μF	0.01 Hz

As Table 2 indicates, most of the bass response is attenuated into a 4-Ω load, an 8-Ω load is adequate, headphone response is good, and drive into line level inputs (a home stereo for example) is exceptional.

using low-ESR capacitors

Low-ESR capacitors are recommended throughout this applications section. A real (as opposed to ideal) capacitor can be modeled simply as a resistor in series with an ideal capacitor. The voltage drop across this resistor minimizes the beneficial effects of the capacitor in the circuit. The lower the equivalent value of this resistance, the more the real capacitor behaves like an ideal capacitor.

APPLICATION INFORMATION

bridged-tied load versus single-ended mode

Figure 35 shows a linear audio power amplifier (APA) in a BTL configuration. The TPA0252 BTL amplifier consists of two class-AB amplifiers driving both ends of the load. There are several potential benefits to this differential drive configuration but initially consider power to the load. The differential drive to the speaker means that as one side is slewing up, the other side is slewing down, and vice versa. This in effect doubles the voltage swing on the load as compared to a ground referenced load. Plugging $2 \times V_{O(PP)}$ into the power equation, where voltage is squared, yields $4 \times$ the output power from the same supply rail and load impedance (see equation 6).

$$V_{(rms)} = \frac{V_{O(PP)}}{2\sqrt{2}} \tag{6}$$

$$\text{Power} = \frac{V_{(rms)}^2}{R_L}$$

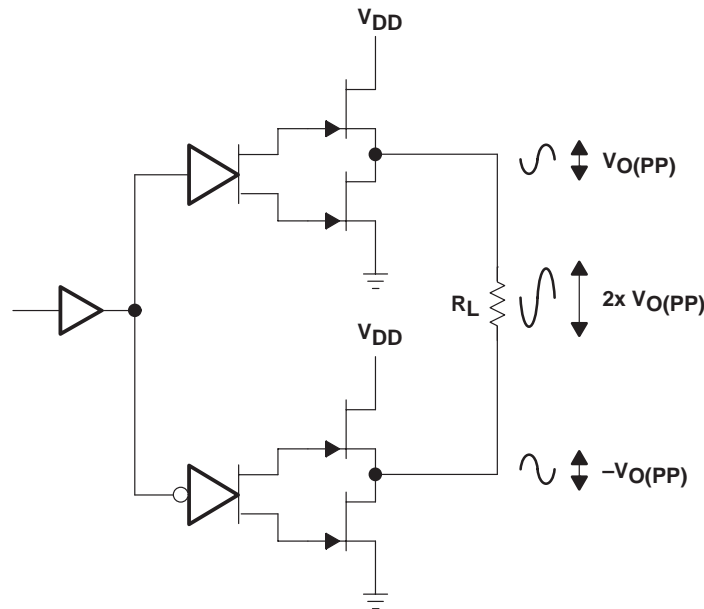

Figure 35. Bridge-Tied Load Configuration

In a typical computer sound channel operating at 5 V, bridging raises the power into an 8-Ω speaker from a single-ended (SE, ground reference) limit of 250 mW to 1 W. In sound power that is a 6-dB improvement, which is loudness that can be heard. In addition to increased power there are frequency response concerns. Consider the single-supply SE configuration shown in Figure 36. A coupling capacitor is required to block the dc offset voltage from reaching the load. These capacitors can be quite large (approximately 33 μF to 1000 μF) so they tend to be expensive, heavy, occupy valuable PCB area, and have the additional drawback of limiting low-frequency performance of the system. This frequency limiting effect is due to the high pass filter network created with the speaker impedance and the coupling capacitance and is calculated with equation 7.

$$f_c = \frac{1}{2\pi R_L C_C} \tag{7}$$

APPLICATION INFORMATION

bridged-tied load versus single-ended mode (continued)

For example, a 68- μF capacitor with an 8- Ω speaker would attenuate low frequencies below 293 Hz. The BTL configuration cancels the dc offsets, which eliminates the need for the blocking capacitors. Low-frequency performance is then limited only by the input network and speaker response. Cost and PCB space are also minimized by eliminating the bulky coupling capacitor.

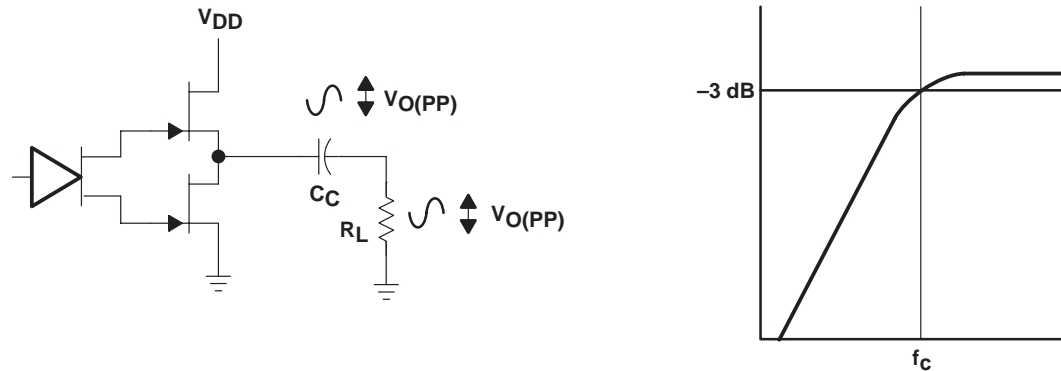

Figure 36. Single-Ended Configuration and Frequency Response

Increasing power to the load does carry a penalty of increased internal power dissipation. The increased dissipation is understandable considering that the BTL configuration produces 4 \times the output power of the SE configuration. Internal dissipation versus output power is discussed further in the crest factor section.

single-ended operation

In SE mode (see Figure 36), the load is driven from the primary amplifier output for each channel (OUT+, terminals 21 and 4).

The amplifier switches single-ended operation when the SE/BTL terminal is held high. This puts the negative outputs in a high-impedance state, and reduces the amplifier's gain to 1 V/V.

APPLICATION INFORMATION

BTL amplifier efficiency

Class-AB amplifiers are notoriously inefficient. The primary cause of these inefficiencies is voltage drop across the output stage transistors. There are two components of the internal voltage drop. One is the headroom or dc voltage drop that varies inversely to output power. The second component is due to the sinewave nature of the output. The total voltage drop can be calculated by subtracting the RMS value of the output voltage from V_{DD} . The internal voltage drop multiplied by the RMS value of the supply current, $I_{DD\text{rms}}$, determines the internal power dissipation of the amplifier.

An easy-to-use equation to calculate efficiency starts out as being equal to the ratio of power from the power supply to the power delivered to the load. To accurately calculate the RMS and average values of power in the load and in the amplifier, the current and voltage waveform shapes must first be understood (see Figure 37).

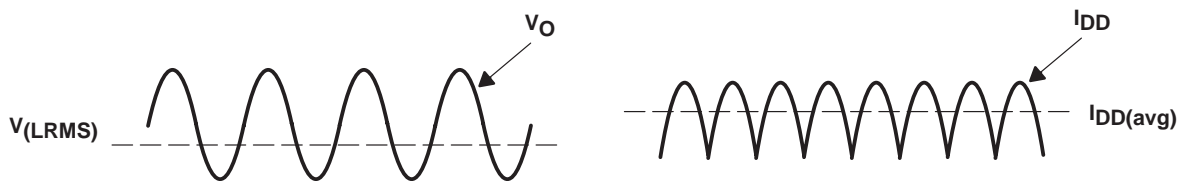

Figure 37. Voltage and Current Waveforms for BTL Amplifiers

Although the voltages and currents for SE and BTL are sinusoidal in the load, currents from the supply are very different between SE and BTL configurations. In an SE application the current waveform is a half-wave rectified shape whereas in BTL it is a full-wave rectified waveform. This means RMS conversion factors are different. Keep in mind that for most of the waveform both the push and pull transistors are not on at the same time, which supports the fact that each amplifier in the BTL device only draws current from the supply for half the waveform. The following equations are the basis for calculating amplifier efficiency.

$$\text{Efficiency of a BTL amplifier} = \frac{P_L}{P_{SUP}} \tag{8}$$

Where:

$$P_L = \frac{V_L \text{ rms}^2}{R_L}, \text{ and } V_{LRMS} = \frac{V_P}{\sqrt{2}}, \text{ therefore, } P_L = \frac{V_P^2}{2R_L}$$

$$\text{and } P_{SUP} = V_{DD} I_{DD\text{avg}} \text{ and } I_{DD\text{avg}} = \frac{1}{\pi} \int_0^\pi \frac{V_P}{R_L} \sin(t) dt = \frac{1}{\pi} \times \frac{V_P}{R_L} [\cos(t)]_0^\pi = \frac{2V_P}{\pi R_L}$$

APPLICATION INFORMATION

Therefore,

$$P_{SUP} = \frac{2 V_{DD} V_P}{\pi R_L}$$

substituting P_L and P_{SUP} into equation 8,

$$\text{Efficiency of a BTL amplifier} = \frac{\frac{V_P^2}{2 R_L}}{\frac{2 V_{DD} V_P}{\pi R_L}} = \frac{\pi V_P}{4 V_{DD}}$$

Where:

$$V_P = \sqrt{2 P_L R_L}$$

Therefore,

$$\eta_{BTL} = \frac{\pi \sqrt{2 P_L R_L}}{4 V_{DD}} \tag{9}$$

- P_L = Power delivered to load
- P_{SUP} = Power drawn from power supply
- V_{LRMS} = RMS voltage on BTL load
- R_L = Load resistance
- V_P = Peak voltage on BTL load
- I_{DDavg} = Average current drawn from the power supply
- V_{DD} = Power supply voltage
- η_{BTL} = Efficiency of a BTL amplifier

Table 3 employs equation 9 to calculate efficiencies for four different output power levels. Note that the efficiency of the amplifier is quite low for lower power levels and rises sharply as power to the load is increased resulting in a nearly flat internal power dissipation over the normal operating range. Note that the internal dissipation at full output power is less than in the half power range. Calculating the efficiency for a specific system is the key to proper power supply design. For a stereo 1-W audio system with 8-Ω loads and a 5-V supply, the maximum draw on the power supply is almost 3.25 W.

Table 3. Efficiency vs Output Power in 5-V 8-Ω BTL Systems

OUTPUT POWER (W)	EFFICIENCY (%)	PEAK VOLTAGE (V)	INTERNAL DISSIPATION (W)
0.25	31.4	2.00	0.55
0.50	44.4	2.83	0.62
1.00	62.8	4.00	0.59
1.25	70.2	4.47†	0.53

† High peak voltages cause the THD to increase.

A final point to remember about class-AB amplifiers (either SE or BTL) is how to manipulate the terms in the efficiency equation to utmost advantage when possible. Note that in equation 9, V_{DD} is in the denominator. This indicates that as V_{DD} goes down, efficiency goes up.



APPLICATION INFORMATION

crest factor and thermal considerations

Class-AB power amplifiers dissipate a significant amount of heat in the package under normal operating conditions. A typical music CD requires 12 dB to 15 dB of dynamic range, or headroom above the average power output, to pass the loudest portions of the signal without distortion. In other words, music typically has a crest factor between 12 dB and 15 dB. When determining the optimal ambient operating temperature the internal dissipated power at the average output power level must be used. From the TPA0252 data sheet, one can see that when the TPA0252 is operating from a 5-V supply into a 3-Ω speaker, 4-W peaks are available. Converting Watts to dB:

$$P_{dB} = 10\text{Log} \left(\frac{P_W}{P_{ref}} \right) = 10\text{Log} \left(\frac{4W}{1W} \right) = 6 \text{ dB} \quad (10)$$

Subtracting the headroom restriction to obtain the average listening level without distortion yields:

- 6 dB – 15 dB = –9 dB (15 dB crest factor)
- 6 dB – 12 dB = –6 dB (12 dB crest factor)
- 6 dB – 9 dB = –3 dB (9 dB crest factor)
- 6 dB – 6 dB = 0 dB (6 dB crest factor)
- 6 dB – 3 dB = 3 dB (3 dB crest factor)

Converting dB back into watts:

$$\begin{aligned} P_W &= 10^{P_{dB}/10} \times P_{ref} \\ &= 63 \text{ mW (18 dB crest factor)} \\ &= 125 \text{ mW (15 dB crest factor)} \\ &= 250 \text{ mW (9 dB crest factor)} \\ &= 500 \text{ mW (6 dB crest factor)} \\ &= 1000 \text{ mW (3 dB crest factor)} \\ &= 2000 \text{ mW (15 dB crest factor)} \end{aligned} \quad (11)$$

This is valuable information to consider when attempting to estimate the heat dissipation requirements for the amplifier system. Comparing the absolute worst case, which is 2 W of continuous power output with a 3-dB crest factor, against 12-dB and 15-dB applications drastically affects maximum ambient temperature ratings for the system. Using the power dissipation curves for a 5-V, 3-Ω system, the internal dissipation in the TPA0252 and maximum ambient temperatures are shown in Table 4.

Table 4. TPA0252 Power Rating, 5-V, 3-Ω, Stereo

PEAK OUTPUT POWER (W)	AVERAGE OUTPUT POWER	POWER DISSIPATION (W/Channel)	MAXIMUM AMBIENT TEMPERATURE
4	2 W (3 dB)	1.7	–3°C
4	1000 mW (6 dB)	1.6	6°C
4	500 mW (9 dB)	1.4	24°C
4	250 mW (12 dB)	1.1	51°C
4	125 mW (15 dB)	0.8	78°C
4	63 mW (18 dB)	0.6	96°C

APPLICATION INFORMATION

crest factor and thermal considerations (continued)

Table 5. TPA0252 Power Rating, 5-V, 8-Ω, Stereo

PEAK OUTPUT POWER	AVERAGE OUTPUT POWER	POWER DISSIPATION (W/Channel)	MAXIMUM AMBIENT TEMPERATURE
2.5 W	1250 mW (3 dB crest factor)	0.55	100°C
2.5 W	1000 mW (4 dB crest factor)	0.62	94°C
2.5 W	500 mW (7 dB crest factor)	0.59	97°C
2.5 W	250 mW (10 dB crest factor)	0.53	102°C

The maximum dissipated power, P_{Dmax} , is reached at a much lower output power level for an 8-Ω load than for a 3 Ω load. As a result, this simple formula for calculating P_{Dmax} may be used for an 8-Ω application:

$$P_{Dmax} = \frac{2V_{DD}^2}{\pi^2 R_L} \tag{12}$$

However, in the case of a 3-Ω load, the P_{Dmax} occurs at a point well above the normal operating power level. The amplifier may therefore be operated at a higher ambient temperature than required by the P_{Dmax} formula for a 3-Ω load.

The maximum ambient temperature depends on the heat sinking ability of the PCB system. The derating factor for the PWP package is shown in the dissipation rating table on page 4. Converting this to Θ_{JA} :

$$\Theta_{JA} = \frac{1}{\text{Derating Factor}} = \frac{1}{0.022} = 45^\circ\text{C/W} \tag{13}$$

To calculate maximum ambient temperatures, first consider that the numbers from the dissipation graphs are per channel, so the dissipated power needs to be doubled for two-channel operation. Given Θ_{JA} , the maximum allowable junction temperature, and the total internal dissipation, the maximum ambient temperature can be calculated with the following equation. The maximum recommended junction temperature for the TPA0252 is 150°C. The internal dissipation figures are taken from the Power Dissipation vs Output Power graphs.

$$\begin{aligned} T_A \text{ Max} &= T_J \text{ Max} - \Theta_{JA} P_D \\ &= 150 - 45(0.6 \times 2) = 96^\circ\text{C} \text{ (15 dB crest factor)} \end{aligned} \tag{14}$$

NOTE:

Internal dissipation of 0.6 W is estimated for a 2-W system with 15-dB crest factor per channel.

Tables 4 and 5 show that for some applications no airflow is required to keep junction temperatures in the specified range. The TPA0252 is designed with thermal protection that turns the device off when the junction temperature surpasses 150°C to prevent damage to the IC. Tables 4 and 5 were calculated for maximum listening volume without distortion. When the output level is reduced, the numbers in the table change significantly. Also, using 8-Ω speakers dramatically increases the thermal performance by increasing amplifier efficiency.

APPLICATION INFORMATION

PC-BEEP operation

The PC-BEEP input allows a system beep to be sent directly from a computer through the amplifier to the speakers with few external components. The input is activated automatically. When the PC-BEEP input is active, both of the LINEIN and HPIN inputs are deselected and both the left and right channels are driven in BTL mode with the signal from PC-BEEP. The gain from the PC-BEEP input to the speakers is fixed at 0.3 V/V and is independent of the volume setting. When the PC-BEEP input is deselected, the amplifier will return to the previous operating mode and volume setting. Furthermore, if the amplifier is in shutdown mode, activating PC BEEP will take the device out of shutdown and output the PC-BEEP signal, then return the amplifier to shutdown mode.

The amplifier will automatically switch to PC-BEEP mode after detecting a valid signal at the PC-BEEP input. The preferred input signal is a square wave or pulse train with an amplitude of 1 V_{pp} or greater. To be accurately detected, the signal must have a minimum of 1 V_{pp} amplitude, rise and fall times of less than 0.1 μs and a minimum of 8 rising edges. When the signal is no longer detected, the amplifier will return to its previous operating mode and volume setting.

If it is desired to ac-couple the PC-BEEP input, the value of the coupling capacitor should be chosen to satisfy the following equation:

$$C_{PCB} \geq \frac{1}{2\pi f_{PCB} (100 \text{ k}\Omega)} \quad (15)$$

The PC-BEEP input can also be dc-coupled to avoid using this coupling capacitor. The pin normally sits at midrail when no signal is present.

TPA0252
STEREO 2-W AUDIO POWER AMPLIFIER
WITH DIGITAL VOLUME CONTROL

SLOS288 – JUNE 2000

APPLICATION INFORMATION

SE/BTL operation

The ability of the TPA0252 to easily switch between BTL and SE modes is one of its most important cost saving features. This feature eliminates the requirement for an additional headphone amplifier in applications where internal stereo speakers are driven in BTL mode but external headphone or speakers must be accommodated. Internal to the TPA0252, two separate amplifiers drive OUT+ and OUT-. The SE/BTL input (terminal 22) controls the operation of the follower amplifier that drives LOUT- and ROUT- (terminals 1 and 11). When SE/BTL is held low, the amplifier is on and the TPA0252 is in the BTL mode. When SE/BTL is held high, the OUT- amplifiers are in a high output impedance state, which configures the TPA0252 as an SE driver from LOUT+ and ROUT+ (terminals 23 and 13). I_{DD} is reduced by approximately one-half in SE mode. Control of the SE/BTL input can be from a logic-level CMOS source or, more typically, from a resistor divider network as shown in Figure 38.

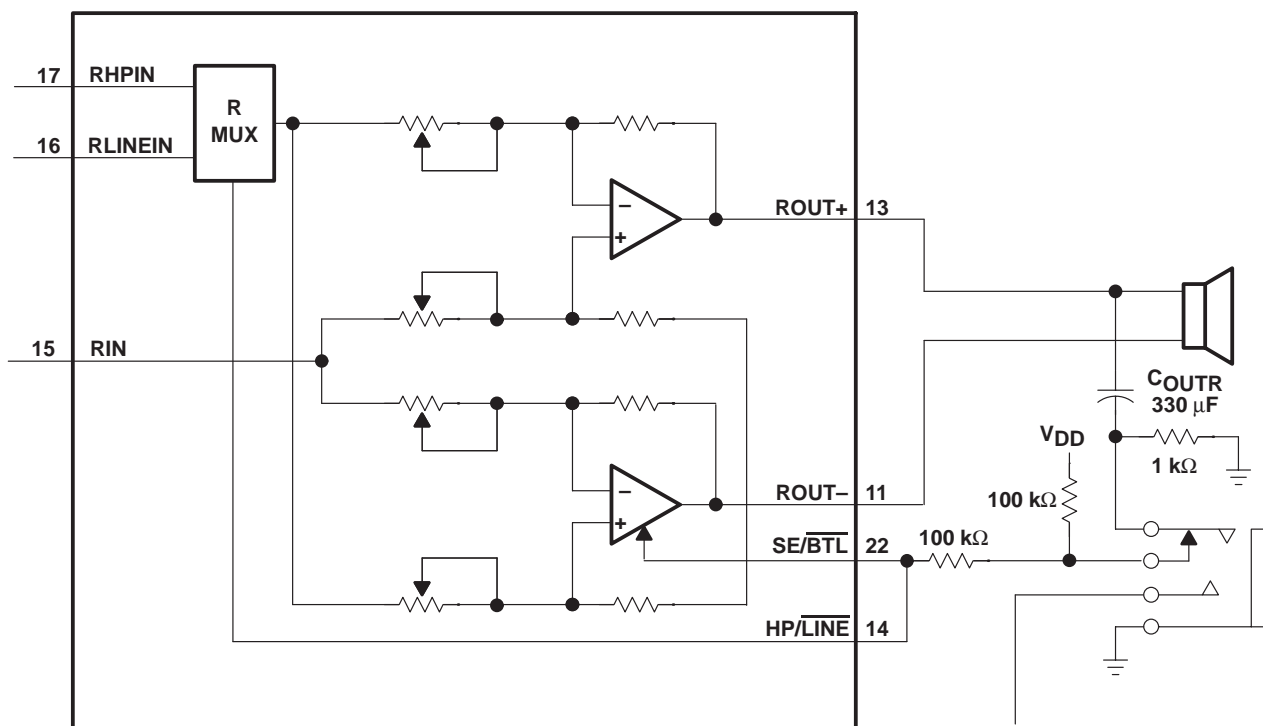

Figure 38. TPA0252 Resistor Divider Network Circuit

Using a readily available 1/8-in. (3.5 mm) stereo headphone jack, the control switch is closed when no plug is inserted. When closed the 100-kΩ/1-kΩ divider pulls the SE/BTL input low. When a plug is inserted, the 1-kΩ resistor is disconnected and the SE/BTL input is pulled high. When the input goes high, the OUT- amplifier is shut down causing the speaker to mute (virtually open-circuits the speaker). The OUT+ amplifier then drives through the output capacitor (C_{OUT}) into the headphone jack.

Input MUX operation

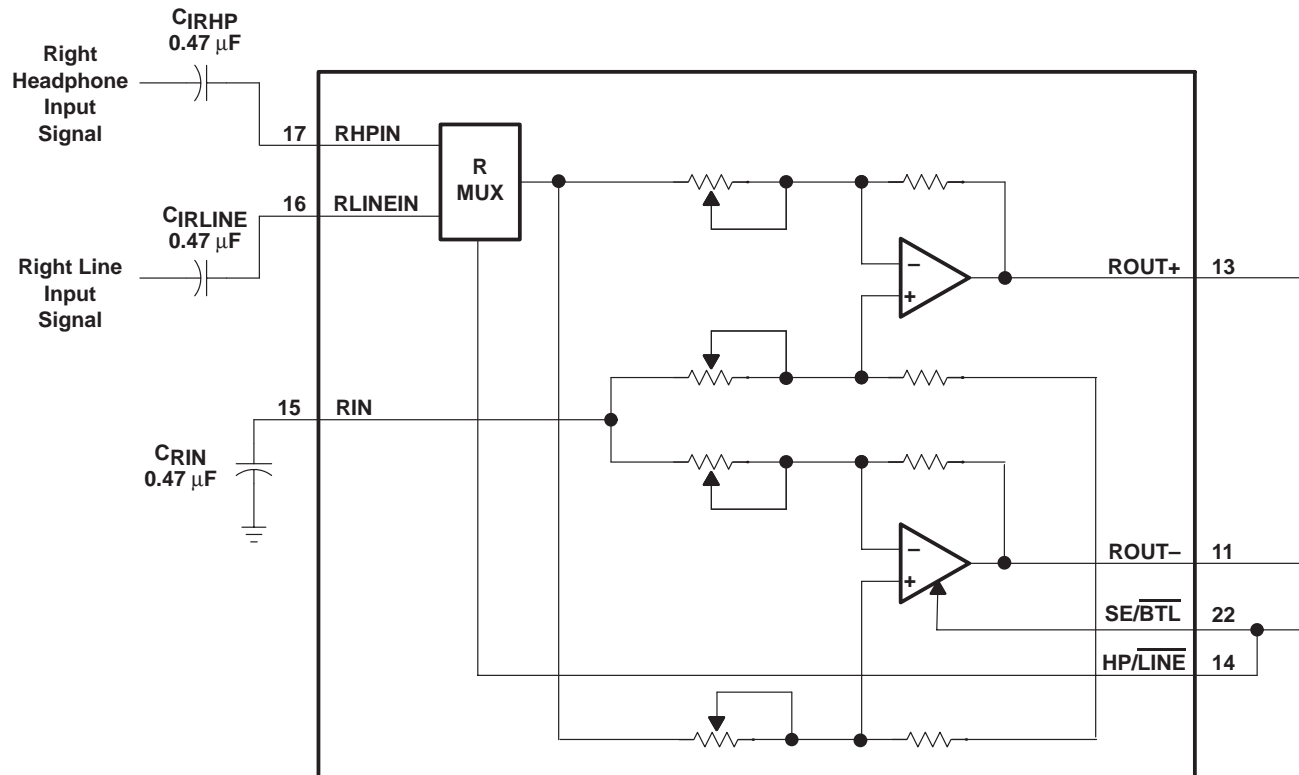

Figure 39. TPA0252 Example Input MUX Circuit

The TPA0252 gives the option of using separate headphone inputs (RHPIN, LHPIN) and line inputs (RLINEIN, LLINEIN). The inputs can be different if the input signal is single-ended. If using a differential input signal, the inputs must be the same, because the inputs share a common RIN, LIN. The typical application shows the input mux control signal HP/LINE tied to SE/BTL, but that is not required. The input mux could be used to select between two inputs that are used in both SE and BTL modes.

If using the TPA0252 with a single-ended input, the RIN and LIN terminals must be tied through a capacitor to ground. RIN and LIN should not be tied to bypass or an offset will occur on the output causing the device to pop when turning on and off.

Input coupling capacitors could be eliminated if using differential inputs but should be used to get maximum output power. If the input capacitors are eliminated, the dc offset must match the voltage on BYPASS or the output power will be limited.

TPA0252
STEREO 2-W AUDIO POWER AMPLIFIER
WITH DIGITAL VOLUME CONTROL

SLOS288 – JUNE 2000

APPLICATION INFORMATION

shutdown modes

The TPA0252 employs a shutdown mode of operation designed to reduce supply current, I_{DD} , to the absolute minimum level during periods of nonuse for battery-power conservation. The $\overline{\text{SHUTDOWN}}$ input terminal should be held high during normal operation when the amplifier is in use. Pulling $\overline{\text{SHUTDOWN}}$ low causes the outputs to mute and the amplifier to enter a low-current state, $I_{DD} = 150 \mu\text{A}$. $\overline{\text{SHUTDOWN}}$ should never be left unconnected because amplifier operation would be unpredictable.

Table 6. Shutdown and Mute Mode Functions

INPUTS†			AMPLIFIER STATE	
$\overline{\text{SE/BTL}}$	$\overline{\text{HP/LINE}}$	$\overline{\text{SHUTDOWN}}$	INPUT	OUTPUT
Low	Low	High	L/R Line	BTL
X	X	Low	X	Mute
Low	High	High	L/R HP	BTL
High	Low	High	L/R Line	SE
High	High	High	L/R HP	SE

† Inputs should never be left unconnected.

X = do not care



MECHANICAL DATA

PWP (R-PDSO-G**)

PowerPAD™ PLASTIC SMALL-OUTLINE PACKAGE

20-PIN SHOWN

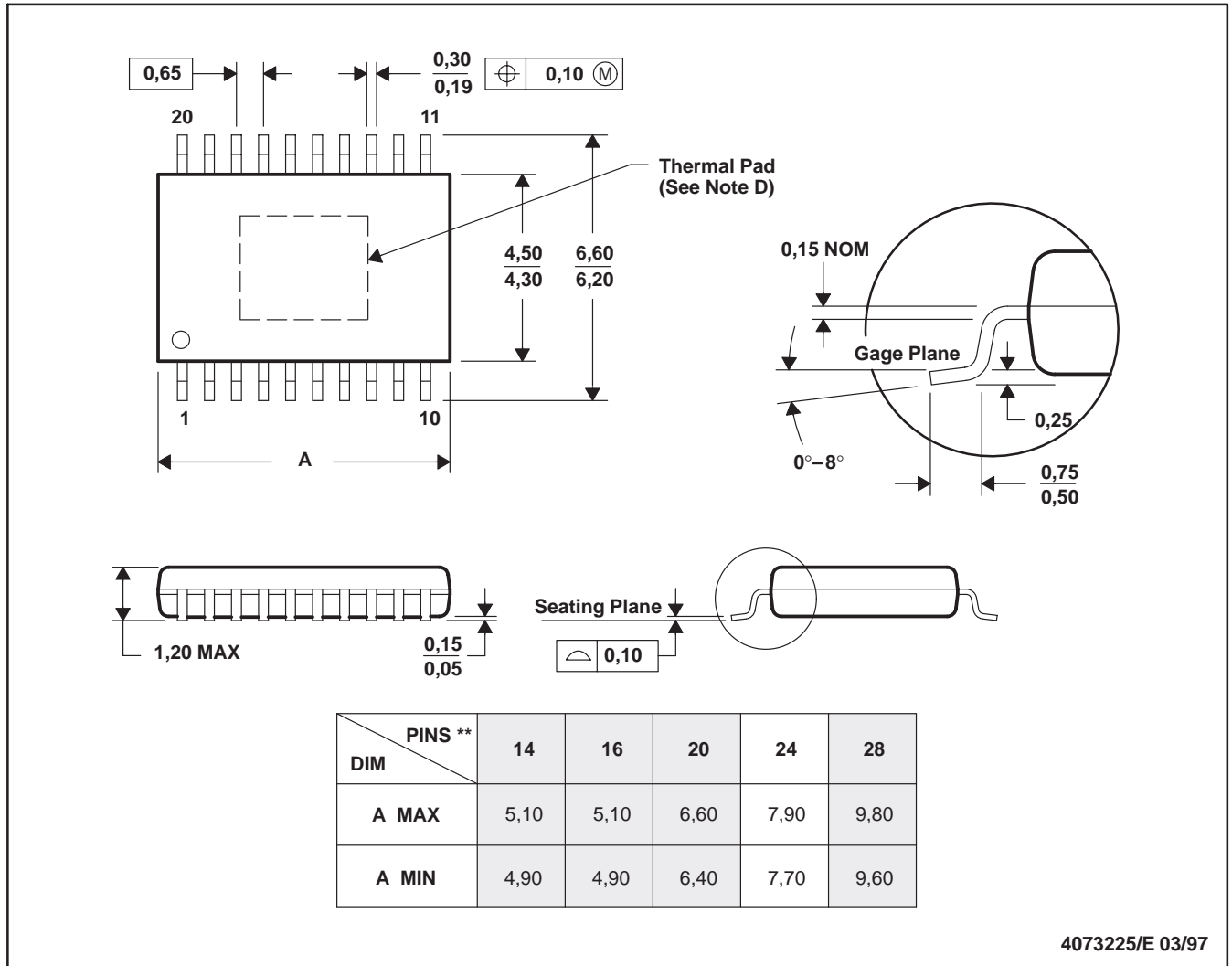

- NOTES: A. All linear dimensions are in millimeters.
 B. This drawing is subject to change without notice.
 C. Body dimensions do not include mold flash or protrusions.
 D. The package thermal performance may be enhanced by bonding the thermal pad to an external thermal plane. This pad is electrically and thermally connected to the backside of the die and possibly selected leads.
 E. Falls within JEDEC MO-153

PowerPAD is a trademark of Texas Instruments Incorporated.

IMPORTANT NOTICE

Texas Instruments and its subsidiaries (TI) reserve the right to make changes to their products or to discontinue any product or service without notice, and advise customers to obtain the latest version of relevant information to verify, before placing orders, that information being relied on is current and complete. All products are sold subject to the terms and conditions of sale supplied at the time of order acknowledgment, including those pertaining to warranty, patent infringement, and limitation of liability.

TI warrants performance of its semiconductor products to the specifications applicable at the time of sale in accordance with TI's standard warranty. Testing and other quality control techniques are utilized to the extent TI deems necessary to support this warranty. Specific testing of all parameters of each device is not necessarily performed, except those mandated by government requirements.

Customers are responsible for their applications using TI components.

In order to minimize risks associated with the customer's applications, adequate design and operating safeguards must be provided by the customer to minimize inherent or procedural hazards.

TI assumes no liability for applications assistance or customer product design. TI does not warrant or represent that any license, either express or implied, is granted under any patent right, copyright, mask work right, or other intellectual property right of TI covering or relating to any combination, machine, or process in which such semiconductor products or services might be or are used. TI's publication of information regarding any third party's products or services does not constitute TI's approval, warranty or endorsement thereof.