

SN54ALS564A, SN74ALS564B OCTAL D-TYPE EDGE-TRIGGERED FLIP-FLOPS WITH 3-STATE OUTPUTS

SDAS164A – APRIL 1982 – REVISED JANUARY 1989

- 3-State Buffer-Type Inverting Outputs Drive Bus-Lines Directly
- Bus-Structured Pinout
- Buffered Control Inputs
- Package Options Include Plastic Small Outline Packages, Ceramic Chip Carriers, and Standard Plastic and Ceramic 300-mil DIPs
- Dependable Texas Instruments Quality and Reliability

description

These 8-bit registers feature inverting 3-state outputs designed specifically for bus driving. They are particularly suitable for implementing buffer registers, I/O ports, bidirectional bus drivers, and working registers.

The 8-bit edge-triggered D-type flip-flops enter data on the low-to-high transition of the clock.

The output control does not affect the internal operation of the flip-flops. Old data can be retained or new data can be entered while the outputs are in the high-impedance state.

The SN54ALS564A is characterized for operation over the full military temperature range of -55°C to 125°C . The SN74ALS564B is characterized for operation from 0°C to 70°C .

FUNCTION TABLE
(each flip-flop)

INPUTS			OUTPUT
OC	CLK	D	\bar{Q}
L	\uparrow	H	L
L	\uparrow	L	H
L	L	X	\bar{Q}_0
H	X	X	Z

SN54ALS564A . . . J PACKAGE
SN74ALS564B . . . DW OR N PACKAGE
(TOP VIEW)

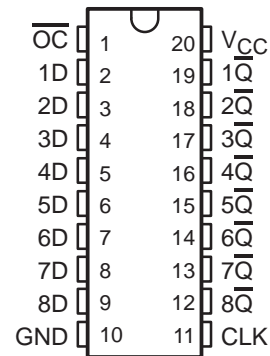

SN54ALS564A . . . FK PACKAGE
(TOP VIEW)

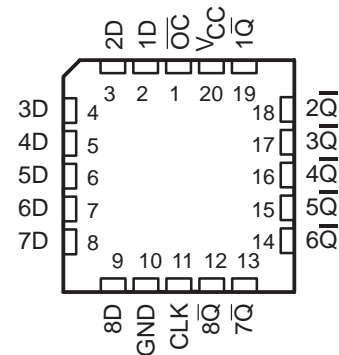

logic symbol†

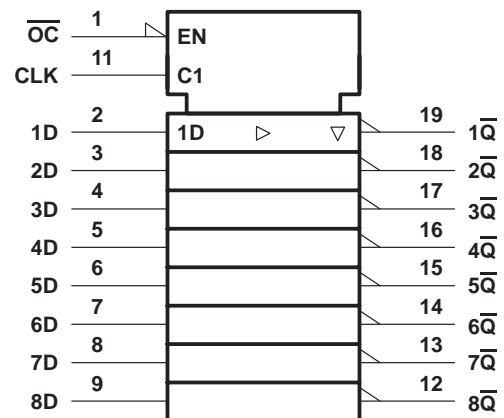

† This symbol is in accordance with ANSI/IEEE Std 91-1984 and IEC Publication 617-12.
Pin numbers shown are for DW, J, and N packages.

SN54ALS564A, SN74ALS564B OCTAL D-TYPE EDGE-TRIGGERED FLIP-FLOPS WITH 3-STATE OUTPUTS

SDAS164A – APRIL 1982 – REVISED JANUARY 1989

logic diagram (positive logic)

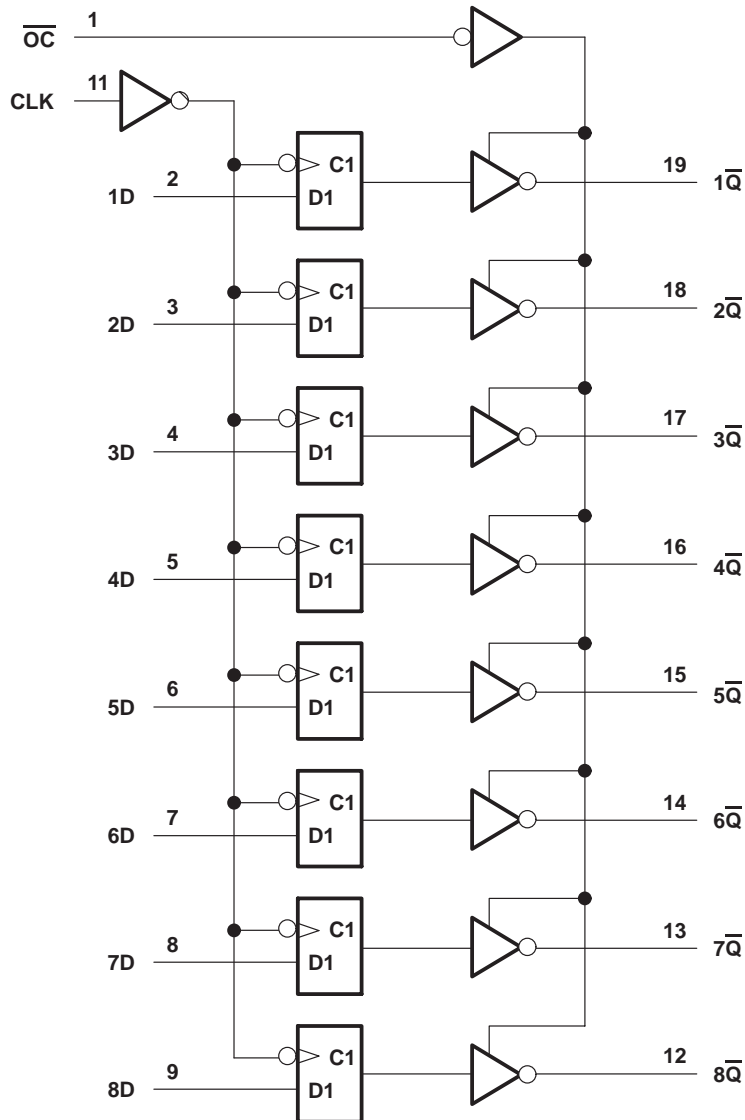

Pin numbers shown are for DW, J, and N packages.

absolute maximum ratings over operating free-air temperature range (unless otherwise noted)

Supply voltage, V_{CC}	7 V
Input voltage	7 V
Voltage applied to a disabled 3-state output	5.5 V
Operating free-air temperature range: SN54ALS564A	-55°C to 125°C
SN74ALS564B	0°C to 70°C
Storage temperature range	-65°C to 150°C

SN54ALS564A, SN74ALS564B OCTAL D-TYPE EDGE-TRIGGERED FLIP-FLOPS WITH 3-STATE OUTPUTS

SDAS164A – APRIL 1982 – REVISED JANUARY 1989

recommended operating conditions

		SN54ALS564A			SN74ALS564B			UNIT
		MIN	NOM	MAX	MIN	NOM	MAX	
V_{CC}	Supply voltage	4.5	5	5.5	4.5	5	5.5	V
V_{IH}	High-level input voltage	2			2			V
V_{IL}	Low-level input voltage			0.7			0.8	V
I_{OH}	High-level output current			-1			-2.6	mA
I_{OL}	Low-level output current			12			24	mA
f_{clock}	Clock frequency	0		25	0		30	MHz
t_w	Pulse duration, CLK high or low	16.5			14			ns
t_{su}	Setup time, data before CLK \uparrow	15			15			ns
t_h	Hold time, data after CLK \uparrow	4			0			ns
T_A	Operating free-air temperature	-55		125	0		70	°C

electrical characteristics over recommended operating free-air temperature range (unless otherwise noted)

PARAMETER	TEST CONDITIONS	SN54ALS564A			SN74ALS564B			UNIT	
		MIN	TYP \dagger	MAX	MIN	TYP \dagger	MAX		
V_{IK}	$V_{CC} = 4.5\text{ V}$, $I_I = -18\text{ mA}$			-1.2			-1.2	V	
V_{OH}	$V_{CC} = 4.5\text{ V to } 5.5\text{ V}$, $I_{OH} = -0.4\text{ mA}$	$V_{CC} - 2$			$V_{CC} - 2$			V	
	$V_{CC} = 4.5\text{ V}$, $I_{OH} = -1\text{ mA}$	2.4	3.3						
	$V_{CC} = 4.5\text{ V}$, $I_{OH} = -2.6\text{ mA}$				2.4	3.2			
V_{OL}	$V_{CC} = 4.5\text{ V}$, $I_{OL} = 12\text{ mA}$		0.25	0.4		0.25	0.4	V	
	$V_{CC} = 4.5\text{ V}$, $I_{OL} = 24\text{ mA}$					0.35	0.5		
I_{OZH}	$V_{CC} = 5.5\text{ V}$, $V_O = 2.7\text{ V}$			20			20	μA	
I_{OZL}	$V_{CC} = 5.5\text{ V}$, $V_O = 0.4\text{ V}$			-20			-20	μA	
I_I	$V_{CC} = 5.5\text{ V}$, $V_I = 7\text{ V}$			0.1			0.1	mA	
I_{IH}	$V_{CC} = 5.5\text{ V}$, $V_I = 2.7\text{ V}$			20			20	μA	
I_{IL}	$V_{CC} = 5.5\text{ V}$, $V_I = 0.4\text{ V}$			-0.2			-0.2	mA	
$I_{O\ddagger}$	$V_{CC} = 5.5\text{ V}$, $V_O = 2.25\text{ V}$			-30			-112	mA	
I_{CC}	$V_{CC} = 5.5\text{ V}$	Outputs high		10	18		10	18	mA
		Outputs low		15	24		15	24	
		Outputs disabled		16	30		16	30	

\dagger All typical values are at $V_{CC} = 5\text{ V}$, $T_A = 25^\circ\text{C}$.

\ddagger The output conditions have been chosen to produce a current that closely approximates one half of the true short-circuit output current, I_{OS} .

SN54ALS564A, SN74ALS564B
OCTAL D-TYPE EDGE-TRIGGERED FLIP-FLOPS
WITH 3-STATE OUTPUTS

SDAS164A – APRIL 1982 – REVISED JANUARY 1989

switching characteristics (see Note 1)

PARAMETER	FROM (INPUT)	TO (OUTPUT)	$V_{CC} = 5\text{ V},$ $C_L = 50\text{ pF},$ $R_1 = 500\ \Omega,$ $R_2 = 500\ \Omega,$ $T_A = 25^\circ\text{C}$	$V_{CC} = 4.5\text{ V to }5.5\text{ V},$ $C_L = 50\text{ pF},$ $R_1 = 500\ \Omega,$ $R_2 = 500\ \Omega,$ $T_A = \text{MIN to MAX}^\dagger$		UNIT		
			'ALS564	SN54ALS564A			SN74ALS564B	
			TYP	MIN	MAX		MIN	MAX
f_{\max}			50	25	30	MHz		
t_{PLH}	CLK	Any \bar{Q}	9	4	15	3	14	ns
t_{PHL}			9	4	15	4	14	
t_{PZH}	\overline{OC}	Any \bar{Q}	11	4	21	3	18	ns
t_{PZL}			11	4	21	4	18	
t_{PHZ}	\overline{OC}	Any \bar{Q}	6	2	12	1	10	ns
t_{PLZ}			8	3	17	2	15	

† For conditions shown MIN or MAX, use the appropriate value specified under recommended operating conditions.

NOTE 1: Load circuit and voltage waveforms are shown in Section 1 of the *ALS/AS Logic Data Book, 1986*.



IMPORTANT NOTICE

Texas Instruments and its subsidiaries (TI) reserve the right to make changes to their products or to discontinue any product or service without notice, and advise customers to obtain the latest version of relevant information to verify, before placing orders, that information being relied on is current and complete. All products are sold subject to the terms and conditions of sale supplied at the time of order acknowledgement, including those pertaining to warranty, patent infringement, and limitation of liability.

TI warrants performance of its semiconductor products to the specifications applicable at the time of sale in accordance with TI's standard warranty. Testing and other quality control techniques are utilized to the extent TI deems necessary to support this warranty. Specific testing of all parameters of each device is not necessarily performed, except those mandated by government requirements.

CERTAIN APPLICATIONS USING SEMICONDUCTOR PRODUCTS MAY INVOLVE POTENTIAL RISKS OF DEATH, PERSONAL INJURY, OR SEVERE PROPERTY OR ENVIRONMENTAL DAMAGE ("CRITICAL APPLICATIONS"). TI SEMICONDUCTOR PRODUCTS ARE NOT DESIGNED, AUTHORIZED, OR WARRANTED TO BE SUITABLE FOR USE IN LIFE-SUPPORT DEVICES OR SYSTEMS OR OTHER CRITICAL APPLICATIONS. INCLUSION OF TI PRODUCTS IN SUCH APPLICATIONS IS UNDERSTOOD TO BE FULLY AT THE CUSTOMER'S RISK.

In order to minimize risks associated with the customer's applications, adequate design and operating safeguards must be provided by the customer to minimize inherent or procedural hazards.

TI assumes no liability for applications assistance or customer product design. TI does not warrant or represent that any license, either express or implied, is granted under any patent right, copyright, mask work right, or other intellectual property right of TI covering or relating to any combination, machine, or process in which such semiconductor products or services might be or are used. TI's publication of information regarding any third party's products or services does not constitute TI's approval, warranty or endorsement thereof.