

# TFT Liquid Crystal Interface Monolithic IC MM1288CQ

---

## Outline

This IC was developed as an interface IC for video equipment having a small monitor. This IC performs  $\gamma$  correction and polarity identification to convert RGB signals into TFT liquid crystal RGB signals. A common inversion circuit and sync separation circuit are built-in.

## Features

1. Power supply voltage +13V, 0V or +5V, -8V
2. Built-in polarity ID circuit
3. Built-in  $\gamma$  correction circuit
4. Common inversion circuit built-in
5. 2 input switch built-in
6. Built-in contrast adjustment circuit
7. Built-in sync separation circuit

## Package

QFP-48A

## Applications

1. Navigation systems
  2. Pachinko games (models with color TFT)
  3. Videophones, conferencing systems
  4. Game equipment
  5. Others
-

Block Diagram

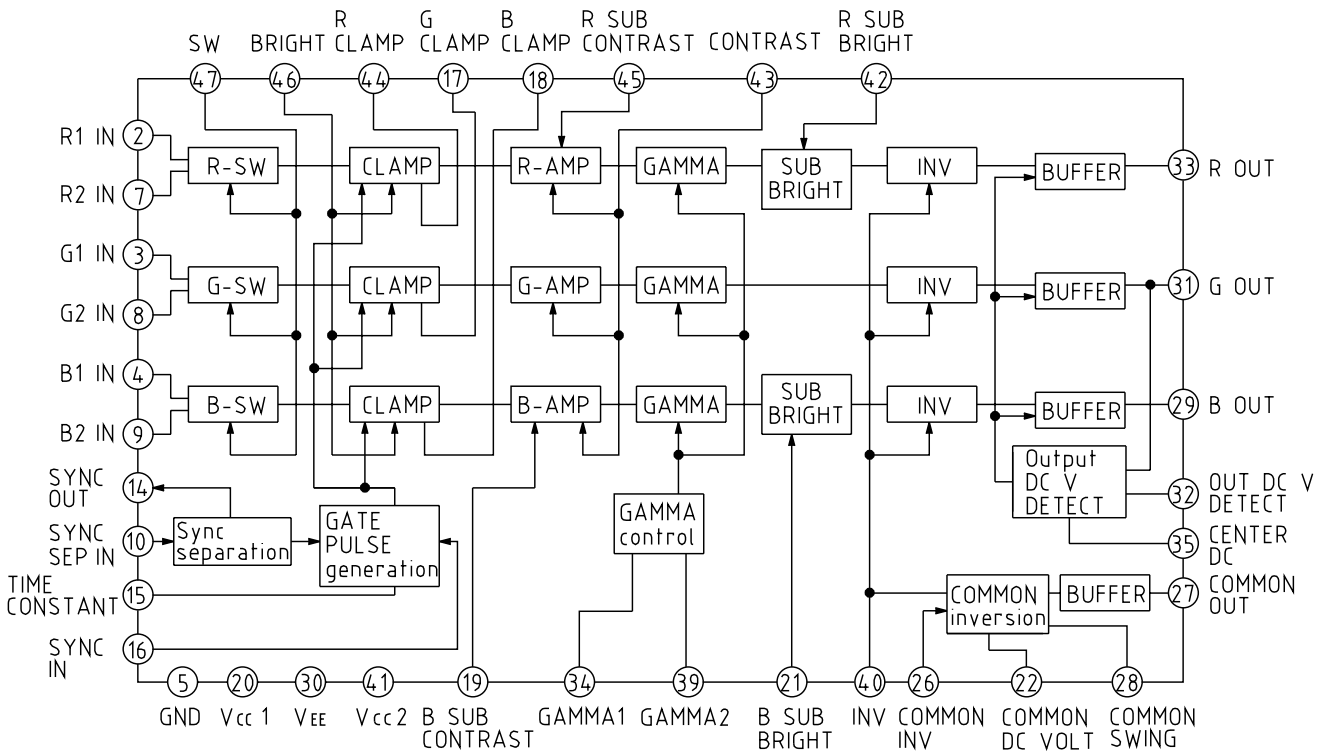

Pin Description

Pin no.	Pin name	Function	Internal equivalent circuit diagram	Pin no.	Pin name	Function	Internal equivalent circuit diagram
1, 6 11, 12 13, 23 24, 25 36, 37 38, 48	NC			14	SYNC OUT	Sync output	
2, 3 4, 7 8, 9	RGB IN	RGB input		15	TIME CONSTANT	Sync integration	
				16	SYNC IN	Sync input	
5	GND	GND pin		17, 18 44	CLAMP (RGB)	Clamp	
10	SYNC SEP IN	Sync separation input					

Pin no.	Pin name	Function	Internal equivalent circuit diagram	Pin no.	Pin name	Function	Internal equivalent circuit diagram
19, 45	SUB CONTRAST	Subcontrast		32	OUT DC V DETECT	G output detection	
43	CONTRAST	Contrast		34	GAMMA1	Gamma correction 1	
20	Vcc1	Positive polarity power supply pin 1		35	CENTER DC	Adjust center voltage	
21, 42	SUB BRIGHT	Sub bright					
22	COMMON DC VOLT	Common operating point adjustment		39	GAMMA2	Gamma correction 2	
26	COMMON INV	Common inversion		40	INV	Inversion	
27	COMMON OUT	Common output					
28	COMMON SWING	Common amplitude adjustment		41	Vcc2	Positive polarity power supply pin 2	
				46	BRIGHT	Bright	
29, 31 33	RGB OUT	RGB output		47	SW	Switch	
							30

## Pin Operation Description

- R1 IN, G1 IN, B1 IN (PINS 2, 3, 4)  
RGB input pins. Please input via coupling capacitor.
- R2 IN, G2 IN, B2 IN (PINS 7, 8, 9)  
RGB input pins. Please input via coupling capacitor.
- GND (5PIN)
- V<sub>EE</sub> (30PIN)  
Negative power supply pin.
- SYNC SEP IN (10PIN)  
Sync separation circuit input pin. Inputs video signal.
- SYNC OUT (14PIN)  
Outputs sync signal separated by sync separation circuit.  
Output signal is H level during sync and L level at other times.
- TIME CONSTANT (15PIN)  
Gate pulse width can be varied by the constant during CR.
- SYNC IN (16PIN)  
A L level pulse (= 0V) is input to this pin during sync, and H level (= 3V) at other times.  
Gate pulse is generated by the OR of the input sync signal and the sync signal separated by the sync separation circuit.
- CLAMP RGB (PINS 44, 17, 18)  
Please add a capacitor for clamp.
- V<sub>CC1</sub>, V<sub>CC2</sub>, (PINS 20, 41)  
Positive power supply pin.
- B SUB CONTRAST (19PIN)  
B signal contrast fine adjustment is done using the DC voltage applied to this pin.
- B SUB BRIGHT (21PIN)  
B signal luminance fine adjustment is done using the DC voltage applied to this pin.
- COMMON DC VOLT (22PIN)  
COMMON output BIAS fine adjustment is done using the DC voltage applied to this pin.
- COMMON INV (26PIN)  
Controls COMMON output polarity.  
When pin voltage is switched to V<sub>CC2</sub>, COMMON output phase reverses from pin 40 input pulse phase to support normally white mode. When pin voltage is switched to V<sub>EE</sub>, it is in phase with pin 40 input pulse.
- COMMON SWING (28PIN)  
COMMON output amplitude can be adjusted using the DC voltage applied to this pin.
- COMMON OUT (27PIN)  
Outputs a pulse for driving the liquid crystal panel COMMON.
- R OUT, G OUT, B OUT (PINS 33, 31, 29)  
Outputs inverted RGB signal according to inversion signal.
- OUT DC V DETECT (32PIN)  
Connect capacitor for smoothing and holding deviance from output center voltage  $(V_{CC2} + V_{EE})/2$ .
- CENTER DC (35PIN)  
Output center voltage can be varied.

Note : GAMMA1, GAMMA2 (Pins 34, 39)

DC voltage applied to these pins sets  $\gamma$  correction DC voltage gain change point.

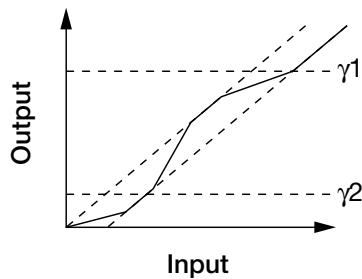

$\gamma$  correction

Output is given characteristics as shown at left according to LCD panel characteristics.

Pins 34 and 39 adjust the slope change position.

INV (40PIN)

The primary color output (pins 29, 31, 33) and COMMON output (pin 27) are inverted according to the inversion pulse input to this pin. When COMMON INV (pin 26) has  $V_{CC2}$  potential, the relationships between the input, output and inversion pulse are as shown in the figure below.

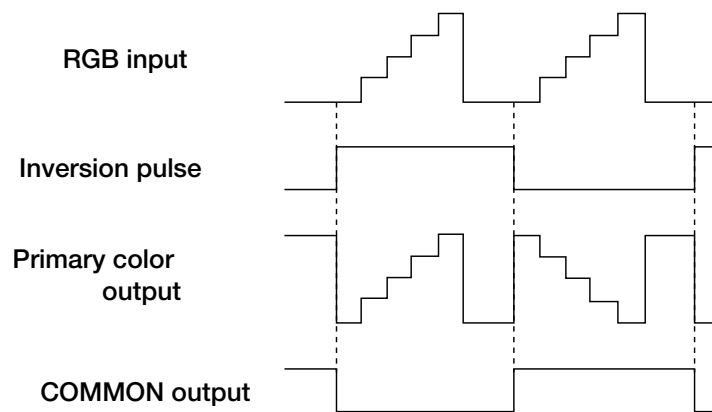

- CONTRAST (43PIN)  
RGB output contrast can be adjusted using the DC voltage applied to this pin.
- R SUB BRIGHT (42PIN)  
R signal luminance fine adjustment is done DC voltage applied to this pin.
- R SUB CONTRAST (45PIN)  
R signal contrast fine adjustment is done DC voltage applied to this pin.
- BRIGHT (46PIN)  
Luminance is adjusted using the DC voltage applied to this pin.
- SW (47PIN)  
Performs RGB input signal 1 and 2 switching.  
Input 1 goes ON for "L" and input 2 goes ON for "H" or OPEN.

### Absolute Maximum Ratings (Ta=25°C)

Item	Symbol	Ratings	Units
Storage temperature	T <sub>STG</sub>	-40~+125	°C
Operating temperature	T <sub>OPR</sub>	-20~+85	°C
Power supply voltage	V <sub>CC1</sub> -GND	6	V
	V <sub>CC2</sub> -V <sub>EE</sub>	15	V
	GND-V <sub>EE</sub>	10	V
Allowable loss 1	P <sub>d</sub> 1	500	mW
Allowable loss 2	P <sub>d</sub> 2	1000*	mW

\*47mm × 75mm × 0.8mm printed circuit board (glass epoxy) board mounted.

**Electrical Characteristics**

(Except where noted otherwise, Ta=25°C, All SW : A, Vcc1=5.0V, Vcc2=13V, GND=0V, VEE=0V, T16; SG1, T40; SG2, V46=3.5V)

Item	Symbol	Measurement conditions	Min.	Typ.	Max.	Units
Vcc1 pin operating power supply voltage range	Vcc1		4.5	5.0	5.5	V
Operating power supply voltage range when on power supply +2	Vcc2+2		10.0	13.0	14.0	V
	VEE+2			GND		V
Operating power supply voltage range when on power supply ±	Vcc2±		4.5	5.0	5.5	V
	VEE±		-8.5	-8.0	-6.5	V
Consumption current 1	Icc1	Vcc1=5V		8.5	15.0	mA
Consumption current 2	Icc2	Vcc2=13V		17.0	22.0	mA
Voltage gain	Gv			17		dB
Voltage gain difference between inputs	Gvsw	SW2~4, 7~9 ; B T2~4, 7~9 ; SG3 Adjust V46 so that T29, 31 and 33 amplitude is 8V.			0.7	dB
					0.7	dB
Reversed/non-reversed voltage gain difference	Gvinv				0.7	dB
RGB voltage gain differences	Gvrgb				0.7	dB
Maximum voltage gain	Gv max.		18			dB
Minimum voltage gain	Gv min.				13	dB
Subcontrast change	ΔGvsub	SW2~4, 19, 45 ; B, T2~4 ; SG3 Adjust V46 so that T29, 31 and 33 amplitude is 8V. Measure ratio between T29, 31 and T33 sine waves when V19 and 45 are 0.5~4.5V.		±1		dB
Input dynamic range	Vindr	SW2~4, 43 ; B, T2~4 ; SG3, V43=1.5V Adjust V46 so that T29, 31 and 33 amplitude is 9V. Vary SG3 amplitude and measure SG3 amplitude at the point where T29, 31 and 33 signals start to be saturated.	1.5	1.9		Vp-p
Switch crosstalk	Ctsw	SW2~4, 43, 47 ; B, T2~4 ; SG4, V47=5V Adjust V46 so that T29, 31 and 33 amplitude is 8V, and adjust V43 so that T29, 31 and 33 sine wave amplitude is 5Vp-p. Vary SW47 in this state and measure 1MHz spectrum change.		-50	-44	dB
		SW7~9, 43, 47 ; B, T7~9 ; SG4, V47=5V Adjust V46 so that T29, 31 and 33 amplitude is 8V, and adjust V43 so that T29, 31 and 33 sine wave amplitude is 5Vp-p. Vary SW47 in this state and measure 1MHz spectrum change.		-50	-44	dB

Item	Symbol	Measurement conditions	Min.	Typ.	Max.	Units
Crosstalk between RGB	$C_{TRGB}$	SW2 ; B T2 ; SG4 Adjust V46 so that T33 amplitude is 8V, and adjust V43 so that T33 sine wave amplitude is 5V <sub>P-P</sub> . Then measure the difference between T33 and T29, 31 signals 1MHz spectrum. Measure in the same way for G → B,R and B → R, G.		-48	-40	dB
Output dynamic range (B-B)	$V_{DRB-B}$	SW2~4 ; B, T2~4 ; SG4, V46=0.5V Measure T29, 31 and 33 signals.	10	11		V <sub>P-P</sub>
Output dynamic range (B-W)	$V_{DRB-W}$	SW2~4, 43 ; B, T2~4 ; SG4, V43=4.5V Adjust V46 so that T29, 31 and 33 amplitude is 9V and measure T29, 31 and 33 sine wave amplitude.	6.0	7.0		V <sub>P-P</sub>
Output center voltage	$V_C$	Adjust V46 so that T29, 31 and 33 amplitude is 0V and measure T29, 31 and 33 DC voltage.	6.3	6.5	6.7	V
Output center voltage change	$\Delta V_C$	Adjust V46 so that T29, 31 and 33 amplitude is 0V and measure the difference T29, 31 and 33 DC voltage when V35=2V and 10V		8.0		V
Bright change	$\Delta V_{BRIT}$	Measure the difference between T29, 31 and 33 signal clamp levels when V46=0.5V and 4.5V.	10.0	13.5		V
Amplitude difference between bright RGB signals	$V_{BRIT RGB}$	Adjust V46 so that T31 amplitude is 5.7V and measure T29 and 33 amplitude ratio.	-0.5		0.5	dB
Sub-bright change	$\Delta V_{SUBB}$	After adjusting V46 so that T29, 31 and 33 amplitude is 6V, with SW21 and 42 : B, vary V21 and 42 between 8~10V and measure the maximum value of the difference between T31 and T29, 33 amplitudes.		±1		V
Frequency characteristic	$f_{max.}$	SW2~4, 29, 31, 33 ; B, T2~4 ; SG4 Adjust V46 so that T29, 31 and 33 amplitude is 8V, then adjust V43 so that T29, 31 and 33 sine wave amplitude is 5V <sub>P-P</sub> . Vary sine wave frequency at measure cutoff frequency.	4.0	5.0		MHz
COMMON output amplitude	$V_{COM}$	Measure T27 amplitude.	6.0	6.5		V <sub>P-P</sub>
COMMON output maximum amplitude	$V_{COM max.}$	SW28 ; B, V28=12V Measure T27 amplitude.	8.0			V <sub>P-P</sub>
COMMON output minimum amplitude	$V_{COM min.}$	SW28 ; B, V28=0V T27 amplitude.	-0.1	0	0.1	V <sub>P-P</sub>
COMMON output center maximum voltage	$V_{CO max.}$	SW22, 28 ; B, V22=5V, V28=0V Measure T27 amplitude.	8.5			V
COMMON output center minimum voltage	$V_{CO min.}$	SW22, 28 ; B, V22=0.5V, V28=0V Measure T27 DC voltage			4.5	V
Sync separation input sensitivity current	$I_{IS}$	Increase current flowing out on T10, and measure outflow current when T14 voltage changes from high to low.	-50	-35	-20	μA
Sync separation output low voltage	$V_{SYNL}$	Measure T14 voltage when 5V is applied to T10.		0.2	0.4	V
Sync input threshold voltage	$V_{TH16}$	Measure T14 inverted input voltage when T16 voltage is changed from 0 → 5V.	1.4	1.9	2.4	V
Sync input input current	$I_{I16}$	SW16 ; B Apply 0V to T16 and measure I16.	-1.5			μA
Subcontrast input current	$I_{I19, I45}$	SW19, 45, 46 ; B Measure I19 and 45 when V19 and 45 are 0.5V and 4.5V.	-60		70	μA

Item	Symbol	Measurement conditions	Min.	Typ.	Max.	Units	
Sub-bright input current	I20, I38	SW21, 42, 46 ; B Measure I21 and 42 when V21 and 42 are 7.5V and 10.5V.	-50		40	μA	
COMMON DC VOLT input current	I21	SW22 ; B Measure I22 when V22=0V.	-100			μA	
COMMON INV threshold voltage	V <sub>TH24</sub>	SW26 ; B Vary V26 between 0~13V and measure V26 when T27 phase inverts.	6.0	6.5	7.0	V	
COMMON INV input current	I24	SW26 ; B Measure I26 when V26=0 and 13V.	-90		90	μA	
COMMON SWING input current	I26	SW28 ; B Measure I28 when V28=9 and 12V.	-60		60	μA	
GAMMA1 input voltage	I34	SW34 ; B Measure I34 when V34=11V.			6	μA	
GAMMA2 input voltage	I39	SW39 ; B Measure I39 when V39=1V.	-6			μA	
INV threshold voltage	V <sub>TH40</sub>	Vary T40 voltage from 0 → 5V and measure the voltage when T27 phase inverts.	2.5	3.0	3.5	V	
INV input current	I40	Measure I40 when V40 is 0V.	-2			μA	
Contrast input current	I43	SW43 ; B Measure I43 when V43 is 0.5V and 4.5V.	-60		70	μA	
Bright input current	I46	Measure I46 when V46=1.7V.			3	μA	
CENTER DC input current	I35	Measure I35 when V35=V <sub>CC2</sub>	105	110	165	μA	
SW threshold voltage	V <sub>TH47</sub>	SW2~4, 47 ; B, T2~4 ; SG3 Adjust V46 so that T29, 31 and 33 amplitude is 8V. Vary V47 voltage from 0 → 5V and measure V47 when T29, 31 and 33 sine waves disappear.	0.8	1.4	2.0	V	
SW input current	I43	SW47 ; B Measure I47 when V47=0V.			4.5	μA	
GAMMA1 fluctuation	ΔV34	SW2~4, 34, 43 ; B, T2~4 ; SG5 Adjust V43 so that T29, 31 and 33 amplitude is 3V. Vary V34 voltage from 3→6V and measure the amount of T29, 31 and 33 voltage change.	0.8	1.2	2.1	V	
GAMMA2 fluctuation	ΔV39	SW2, 3, 4, 39, 43 ; B, T2~4 ; SG5 Adjust V43 so that T29, 31 and 33 amplitude is 3V. Vary V39 voltage from 6.2→8V and measure the amount of T29, 31 and 33 voltage change.	0.8	1.2	2.1	V	
H-to-L common transport delay time	t <sub>PHL</sub>	SW27, 28 ; B, T40 ; SG6 Adjust V28 so that T27 amplitude is 6V.			2	μS	
L-to-H common transport delay time	t <sub>PLH</sub>				2	μS	
COMMON fall time	t <sub>THL</sub>				2	3	μS
COMMON rise time	t <sub>TLH</sub>				2	3	μS
Difference in COMMON rise and fall times	Δtr		Δtr=   t <sub>THL</sub> -t <sub>TLH</sub>			2	μS
H-to-L primary color signal transport delay time	t <sub>PHL</sub>	SW29, 31, 33 ; B, T40 ; SG6 Adjust V46 so that T29, 31 and 33 amplitude is 8V.			2	μS	
L-to-H primary color signal transport delay time	t <sub>PLH</sub>				2	μS	
Primary color signal fall time	t <sub>THL</sub>				1	2	μS
Primary color signal rise time	t <sub>TLH</sub>				1	2	μS
Difference in primary color signal rise and fall times	Δtr		Δtr=   t <sub>THL</sub> -t <sub>TLH</sub>			1	μS

### Example of Power Supply Use

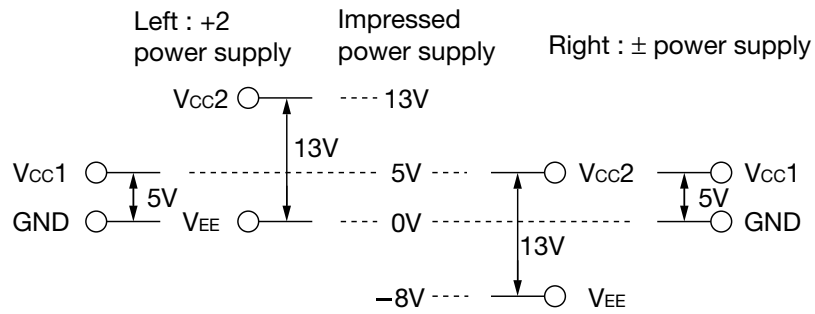

### Input Signal Waveforms

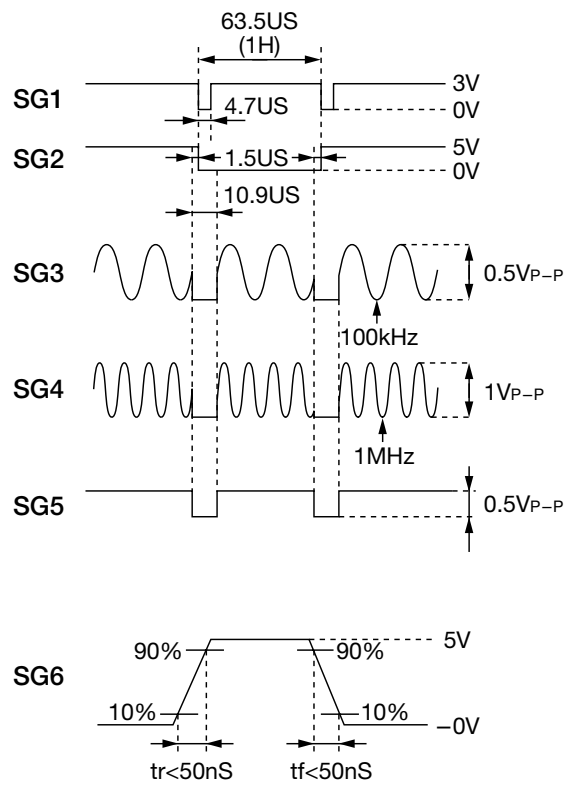

Measuring Circuit

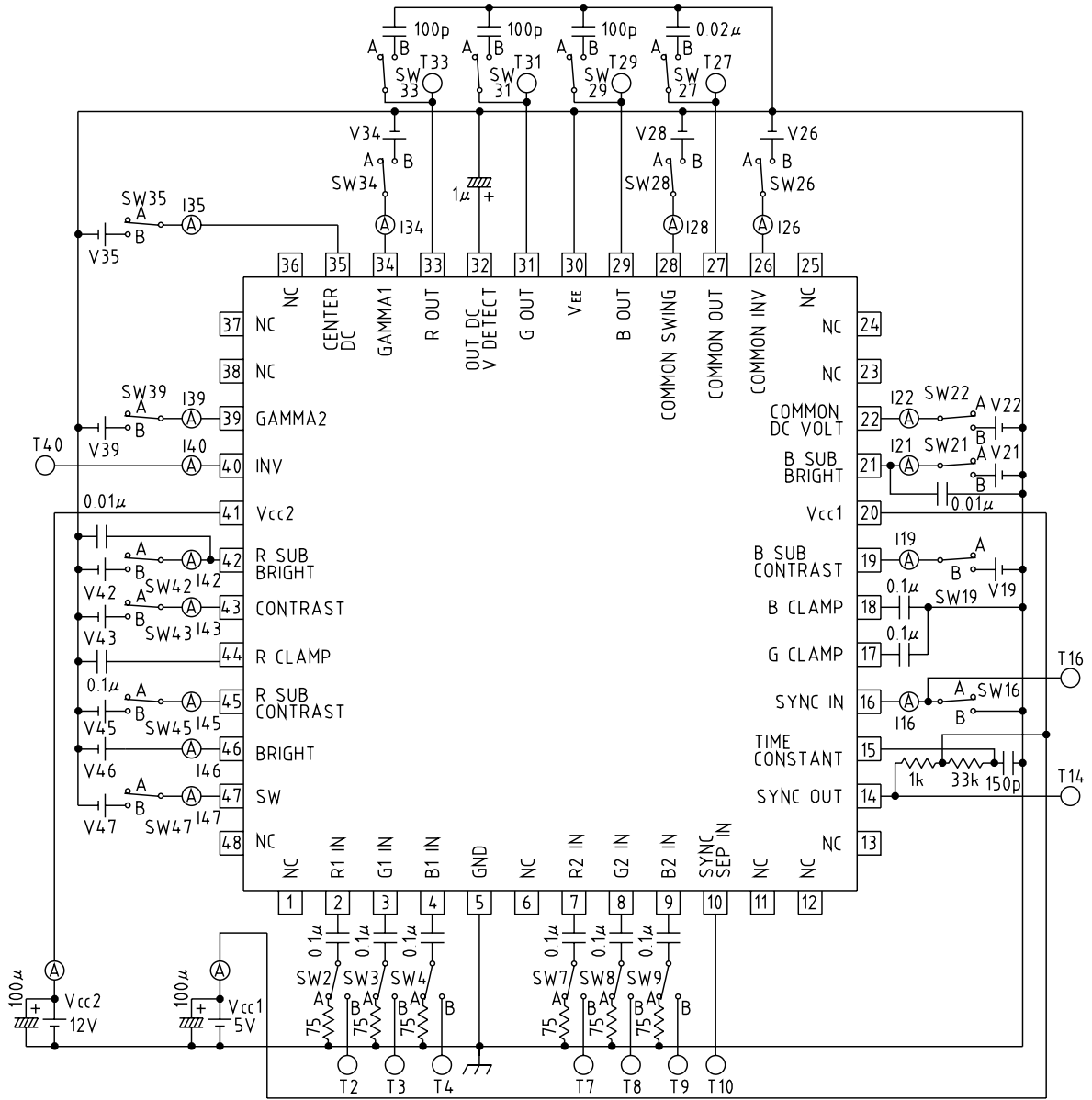

Application Circuits

Basic Connection Diagram 1 (Vcc1=5V, Vcc2=13V)

