

TENTATIVE

TOSHIBA PHOTOCOUPLER GaAlAs IRED + PHOTO IC

TLP759(IGM)

TRANSISTOR INVERTOR

INVERTER FOR AIR CONDITIONER

LINE RECEIVER

IPM INTERFACES

The TOSHIBA TLP759 (IGM) consists of a GaAlAs high-output light emitting diode and a high speed detector of one chip photo diode-transistor.

This unit is 8-lead DIP.

TLP759 (IGM) has no internal base connection, and a Faraday shield integrated on the photodetector chip provides an effective common mode noise transient immunity.

TLP759 (IGM) guarantees minimum and maximum of propagation delay time, switching time dispersion, and high common mode transient immunity. Therefore TLP759 (IGM) is suitable for isolation interface between IPM (Intelligent Power Module) and control IC circuits in motor control application.

- Isolation Voltage : 5000V_{rms} (Min.)
- Common Mode Transient Immunity : $\pm 10\text{kV} / \mu\text{s}$ (Min.)
@ $V_{CM}=1500\text{V}$
- Switching Time : $t_{pHL}, t_{pLH}=0.1\mu\text{s}$ (Min.)
= $0.8\mu\text{s}$ (Max.)
@ $I_F=10\text{mA}, V_{CC}=15\text{V}, R_L=20\text{k}\Omega, T_a=25^\circ\text{C}$
- Switching Time Dispersion : $0.7\mu\text{s}$ (Max.)
($|t_{pLH}-t_{pHL}|$)
- TTL Compatible
- UL Recognized : UL1577, Fle No.E67349

Unit in mm

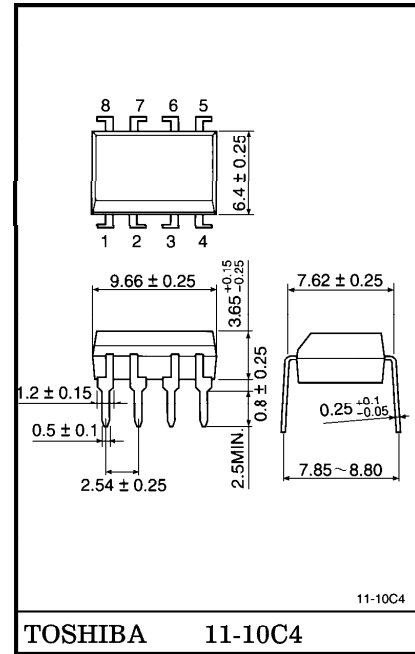

Weight : 0.54g

PIN CONFIGURATION (Top view)

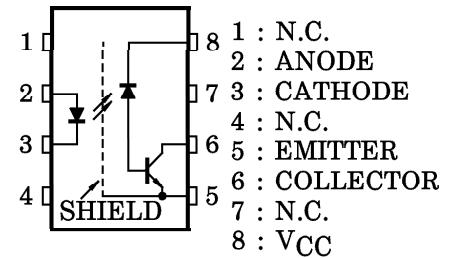

SCHEMATIC

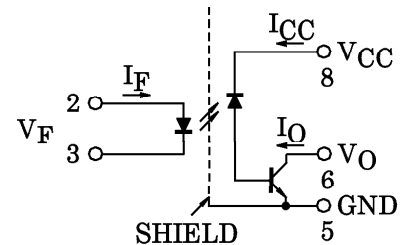

961001EAA2

● TOSHIBA is continually working to improve the quality and the reliability of its products. Nevertheless, semiconductor devices in general can malfunction or fail due to their inherent electrical sensitivity and vulnerability to physical stress. It is the responsibility of the buyer, when utilizing TOSHIBA products, to observe standards of safety, and to avoid situations in which a malfunction or failure of a TOSHIBA product could cause loss of human life, bodily injury or damage to property. In developing your designs, please ensure that TOSHIBA products are used within specified operating ranges as set forth in the most recent products specifications. Also, please keep in mind the precautions and conditions set forth in the TOSHIBA Semiconductor Reliability Handbook.

● The information contained herein is presented only as a guide for the applications of our products. No responsibility is assumed by TOSHIBA CORPORATION for any infringements of intellectual property or other rights of the third parties which may result from its use. No license is granted by implication or otherwise under any intellectual property or other rights of TOSHIBA CORPORATION or others.

● The information contained herein is subject to change without notice.

- Option (D4) type
 VDE Approved : DIN VDE0884 / 06.92,
 Maximum Operating Insulation Voltage : 890V_{PK}
 Highest Permissible Over Voltage : 6000V_{PK}

(Note 1) When a VDE0884 approved type is needed, please designate the "Option (D4)"

- Structural Parameter 7.62mm Pitch TLP759 (IGM)
 Creepage Distance : 7.0mm (Min.)
 Clearance : 7.0mm (Min.)
 Insulation Thickness : 0.4mm (Min.)

MAXIMUM RATINGS (Ta = 25°C)

CHARACTERISTIC		SYMBOL	RATING	UNIT
LED	Forward Current (Note 2)	I _F	25	mA
	Pulse Forward Current (Note 3)	I _{FP}	50	mA
	Peak Transient Forward Current (Note 4)	I _{FPT}	1	A
	Reverse Voltage	V _R	5	V
	Diode Power Dissipation (Note 5)	P _D	45	mW
Detector	Output Current	I _O	8	mA
	Peak Output Current	I _{OP}	16	mA
	Output Voltage	V _O	-0.5~20	V
	Supply Voltage	V _{CC}	-0.5~30	V
	Output Power Dissipation (Note 6)	P _O	100	mW
Operating Temperature Range		T _{opr}	-55~100	°C
Storage Temperature Range		T _{stg}	-55~125	°C
Lead Solder Temperature (10s) (Note 7)		T _{sol}	260	°C
Isolation Voltage (AC, 1min., R.H. ≤ 60%, Ta = 25°C) (Note 8)		BV _S	2500	V _{rms}

(Note 2) : Derate 0.8mA above 70°C.

(Note 3) : 50% duty cycle, 1ms pulse width.
 Derate 1.6mA / °C above 70°C.

(Note 4) : Pulse width PW ≤ 1μs, 300pps.

(Note 5) : Derate 0.9mW / °C above 70°C.

(Note 6) : Derate 2mW / °C above 70°C.

(Note 7) : Soldering portion of lead : up to 2mm from the body of the device.

(Note 8) : Device considered a two terminal device : pins 1, 2, 3 and 4 shorted together and pins 5, 6, 7 and 8 shorted together.

ELECTRICAL CHARACTERISTICS (Ta = 25°C)

CHARACTERISTIC		SYMBOL	TEST CONDITION	MIN.	TYP.	MAX.	UNIT
LED	Forward Voltage	V_F	$I_F = 16\text{mA}$		1.65	1.85	V
	Forward Voltage Temperature Coefficient	$\Delta V_F / \Delta T_a$	$I_F = 16\text{mA}$	—	-2	—	mV/°C
	Reverse Current	I_R	$V_R = 5\text{V}$	—	—	10	μA
	Capacitance between Terminal	C_T	$V_F = 0, f = 1\text{MHz}$	—	45	—	pF
Detector	High Level Output Current	$I_{OH(1)}$	$I_F = 0\text{mA}, V_{CC} = V_O = 5.5\text{V}$	—	3	500	nA
		$I_{OH(2)}$	$I_F = 0\text{mA}, V_{CC} = 30\text{V}$ $V_O = 20\text{V}$	—	—	5	μA
		I_{OH}	$I_F = 0\text{mA}, V_{CC} = 30\text{V}$ $V_O = 20\text{V}, T_a = 70^\circ\text{C}$	—	—	50	
	High Level Supply Voltage	I_{CCH}	$I_F = 0\text{mA}, V_{CC} = 30\text{V}$	—	0.01	1	μA
	Supply Voltage	V_{CC}	$I_{CC} = 0.01\text{mA}$	30	—	—	V
	Output Voltage	V_O	$I_O = 0.5\text{mA}$	20	—	—	V

COUPLED ELECTRICAL CHARACTERISTICS (Ta = 25°C)

CHARACTERISTIC	SYMBOL	TEST CONDITION	MIN.	TYP.	MAX.	UNIT
Current Transfer Ratio	I_O / I_F	$I_F = 10\text{mA}, V_{CC} = 4.5\text{V}$ $V_O = 0.4\text{V}$	25	35	75	%
		$I_F = 16\text{mA}, V_{CC} = 4.5\text{V}$ $V_O = 0.4\text{V}, T_a = -25 \sim 100^\circ\text{C}$	15	—	—	
Low Level Output Voltage	V_{OL}	$I_F = 16\text{mA}, V_{CC} = 4.5\text{V}$ $I_O = 2.4\text{mA}$	—	—	0.4	V

ISOLATION CHARACTERISTICS (Ta = 25°C)

CHARACTERISTIC	SYMBOL	TEST CONDITION	MIN.	TYP.	MAX.	UNIT
Capacitance Input to Output	C_S	$V = 0, f = 1\text{MHz}$ (Note 8)	—	0.8	—	pF
Isolation Resistance	R_S	R.H. $\leq 60\%$, $V_S = 500\text{V}$ (Note 8)	1×10^{12}	10^{14}	—	Ω
Isolation Voltage	BV_S	AC, 1 minute	5000	—	—	V_{rms}
		AC, 1 second, in oil	—	10000	—	Vdc
		DC, 1 minute, in oil	—	10000	—	

SWITCHING CHARACTERISTICS (Ta = 25°C, VCC = 15V)

CHARACTERISTIC	SYMBOL	TEST CIRCUIT	TEST CONDITION	MIN.	TYP.	MAX.	UNIT
Propagation Delay Time (H→L)	t_{pHL}	1	$I_F = 10\text{mA}$, $R_L = 20\text{k}\Omega$	0.1	0.45	0.8	μs
			$I_F = 10\text{mA}$, $R_L = 20\text{k}\Omega$ $T_a = 0 \sim 85^\circ\text{C}$	0.1	0.45	0.9	
Propagation Delay Time (L→H)	t_{pLH}		$I_F = 10\text{mA}$, $R_L = 20\text{k}\Omega$ $T_a = -25 \sim 100^\circ\text{C}$	0.1	0.45	1.0	
Switching Time Dispersion between ON and OFF	$ t_{pLH} - t_{pHL} $		$I_F = 10\text{mA}$, $R_L = 20\text{k}\Omega$	—	0.15	0.7	μs
			$I_F = 10\text{mA}$, $R_L = 20\text{k}\Omega$ $T_a = 0 \sim 85^\circ\text{C}$	—	0.25	0.8	
			$I_F = 10\text{mA}$, $R_L = 20\text{k}\Omega$ $T_a = -25 \sim 100^\circ\text{C}$	—	0.25	0.9	
Common Mode Transient Immunity at Logic High Output (Note 9)	CM_H	2	$I_F = 0\text{mA}$ $V_{CM} = 1500V_{p-p}$ $R_L = 20\text{k}\Omega$	10000	15000	—	$V / \mu\text{s}$
Common Mode Transient Immunity at Logic Low Output (Note 9)	CM_L		$I_F = 10\text{mA}$ $V_{CM} = 1500V_{p-p}$ $R_L = 20\text{k}\Omega$	-10000	-15000	—	$V / \mu\text{s}$

(Note 9) : CM_L is the maximum rate of fall of the common mode voltage that can be sustained with the output voltage in the logic low state ($V_O < 1V$).

CM_H is the maximum rate of rise of the common mode voltage that can be sustained with the output voltage in the logic high state ($V_O < 4V$).

(Note 10) : Maximum electrostatic discharge voltage for any pins : 100V (C=200pF, R=0).

TEST CIRCUIT 1 : Switching time test circuit

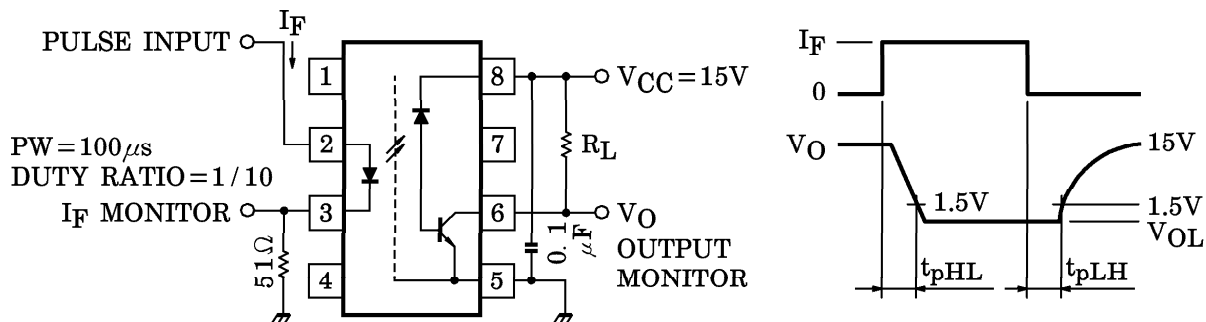

TEST CIRCUIT 2 : Common mode noise immunity test circuit

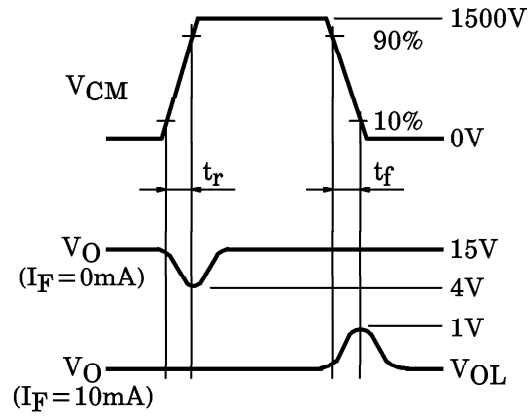
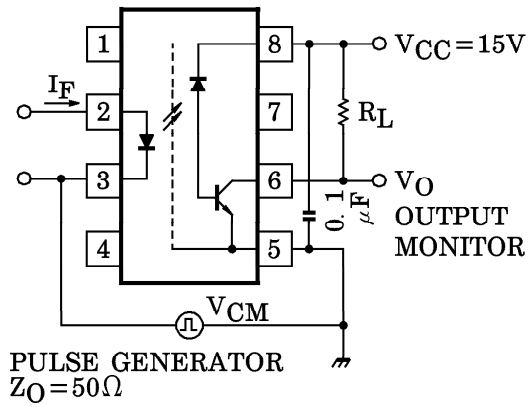

$$CM_H = \frac{1200 \text{ (V)}}{t_r \text{ (}\mu\text{s)}}, CM_L = \frac{1200 \text{ (V)}}{t_f \text{ (}\mu\text{s)}}$$