

***THIS DOCUMENT IS FOR MAINTENANCE
PURPOSES ONLY AND IS NOT
RECOMMENDED FOR NEW DESIGNS***

SL610, SL611 & SL612

RF/IF AMPLIFIER

The SL610C, SL611C and SL612C are RF voltage amplifier with AGC facilities. The voltage gain is 10, 20 and 50 times respectively and the upper frequency response varies from 15MHz to 120MHz according to type .

FEATURES

- Wide AGC Range: 50dB
- Easy Interfacing
- Integral Power Supply RF Decoupling

APPLICATIONS

- RF Amplifiers
- IF Amplifiers

QUICK REFERENCE DATA

- Supply Voltage: 6V
- Voltage Gain: 20dB to 34dB

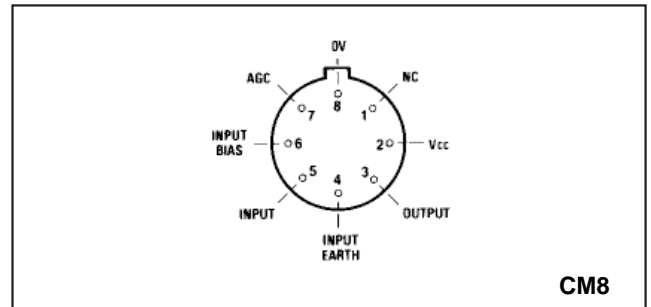

Fig.1 Pin connections (top view)

ABSOLUTE MAXIMUM RATINGS

Supply voltage:	12V
Storage temperature:	-65°C to +150°C
Operating temperature range	-30°C to +85°C
Chip-to-ambient	225°C/W
Chip-to-case	65°C/W

ORDERING INFORMATION

- SL610/1/2 C CM
- SL610 NA 1C
- SL612 NA 1C

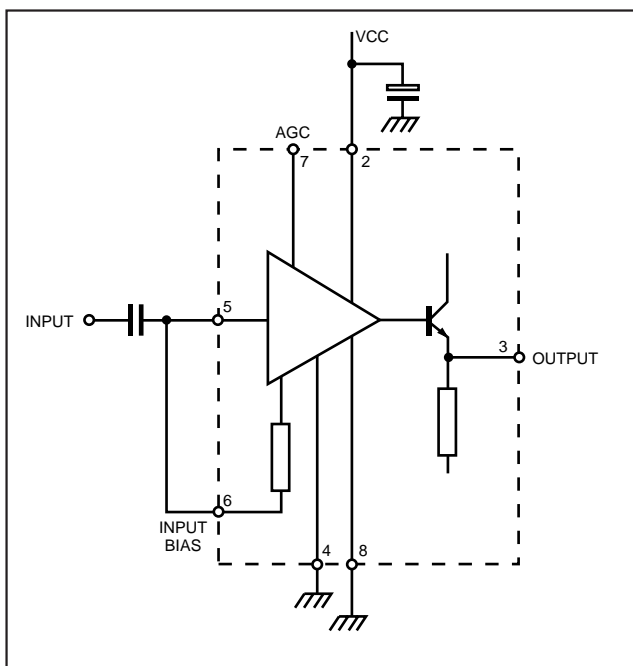

Fig.2 Block diagram

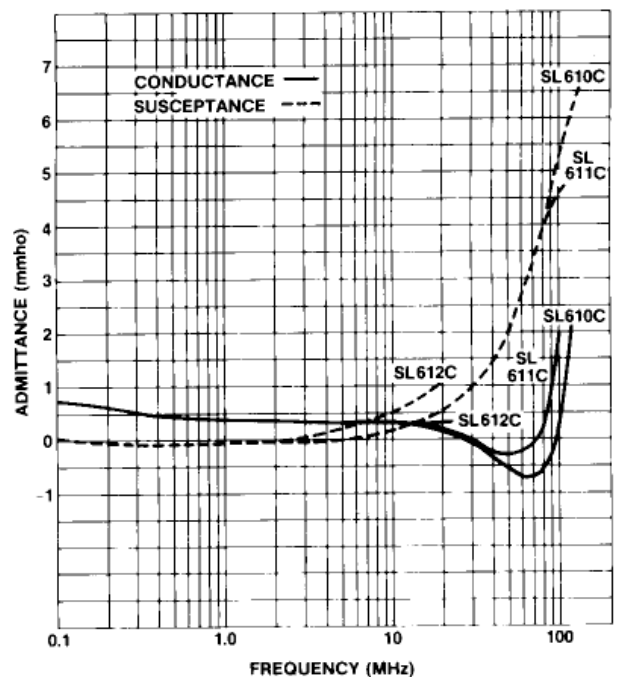

Fig.3 Input admittance with o/c output (G_{11})

SL610/611 & 612

ELECTRICAL CHARACTERISTICS

These characteristics are guaranteed over the following conditions (unless otherwise stated)

Supply voltage VCC: 6V
 Ambient temperature: 22°C ± 2°C
 Test frequency: SL610C 30MHz
 SL611C 30MHz
 SL612C 1.75MHz

Characteristics	Circuit	Value			Units	Conditions
		Min.	Typ.	Max.		
Supply current	SL610C SL611C SL612C		15 15 3.3	20 20 5	mA mA mA	No signal, Pin 3 open circuit
Voltage gain	SL610C SL611C SL612C	18 24 32	20 26 34	22 28 36	dB dB dB	R _s = 50Ω R _L = 22°C T _{amb} = 22°C
Cut-off frequency (-3dB)	SL610C SL611C SL612C	85 50 10	120 80 15		MHz MHz MHz	
Max. output signal (max. AGC)			1.0		V rms	R _L = 150Ω (SL610C/611C) R _L = 1.2kΩ (SL612C)
Max. input signal (max. AGC) AGC range	SL610C SL611C SL612C	40 40 60	250 50 50		mV rms dB dB dB	Pin 7 0V to 5.1V
AGC current			0.15	0.6	mA	Current into pin 7 at 5.1V

APPLICATION NOTES

Input circuit

The SL610C, SL611C and SL612C are normally used with pins 5 and 6 connected together and with the input connected via a capacitor as shown in Fig.2.

The input impedance is negative between 30MHz and 100MHz (SL610C, SL611C only) and is shown in Fig.3. The source and inductive is should be shunted by a 1kΩ resistor to prevent oscillation.

An alternative circuit with improved noise figure is shown in Fig.4.

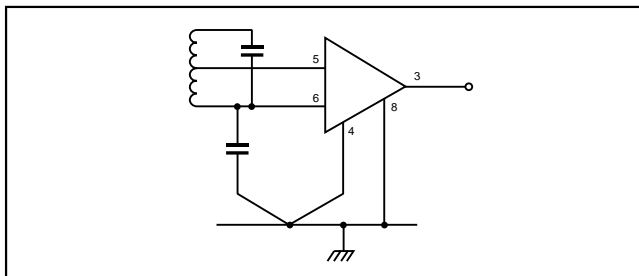

Fig.4 Alternative input circuit

Output circuit

The output stage is an emitter follower and has a negative output impedance at certain frequencies as shown in Fig.5.

To prevent oscillation when the load is capacitive a 47Ω resistor should be connected in series with the output.

AGC

When pin 7 is open circuit or connected to a voltage less than 2V the voltage gain is normal. As the AGC voltage is increased there is a reduction in gain as shown in Fig.6. This reduction varies with temperature.

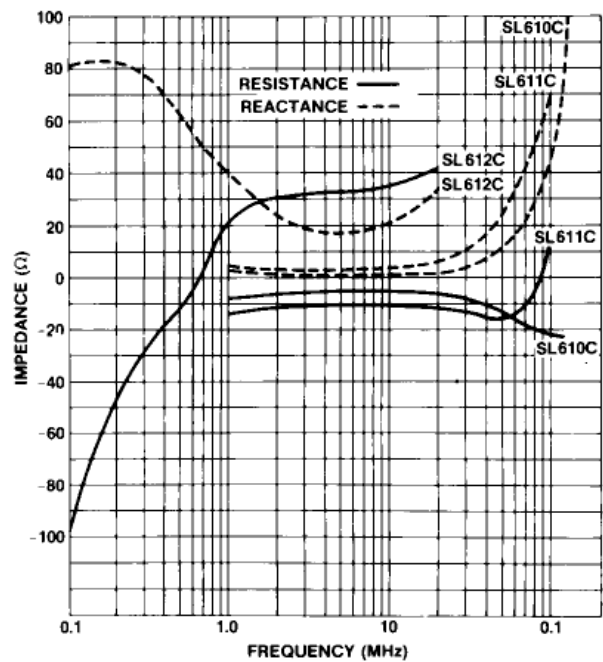

Fig.5 Typical output impedance with s/c input (G22)

Typical applications

The circuit of Fig.7 is a general purpose RF preamplifier. The voltage gain (from pin 5 to pin 3) is shown in Fig.8. Fig.9 is the IF section of a simple SSB transceiver. At 9MHz it has a gain of 100dB.

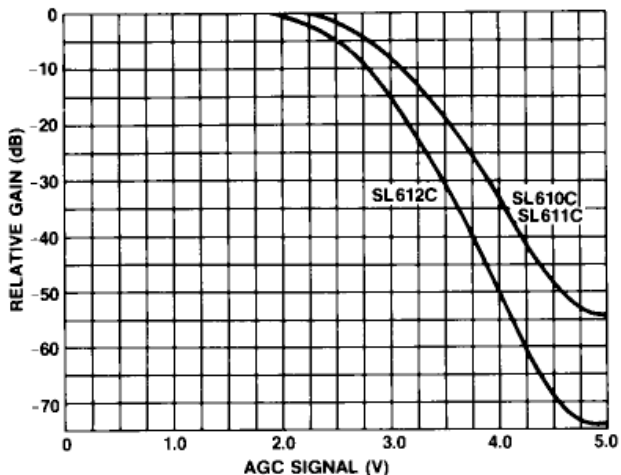

Fig.6 AGC characteristics (typical)

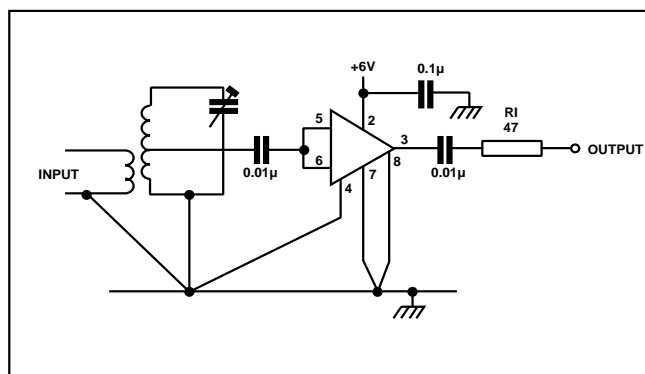

Fig.7 RF preamplifier

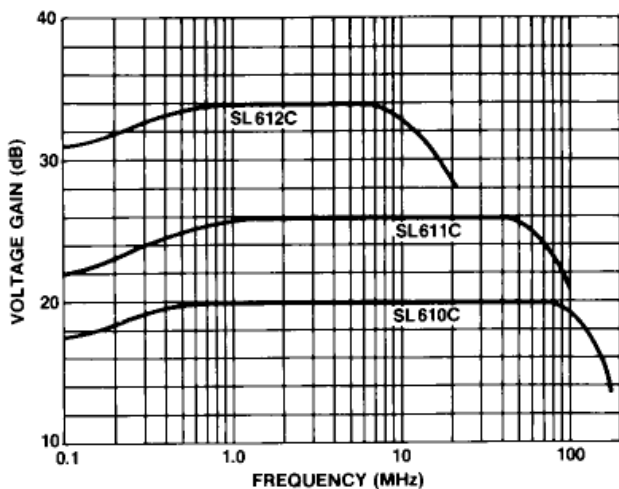

Fig.8 Typical voltage gain (RS = 50Ω)

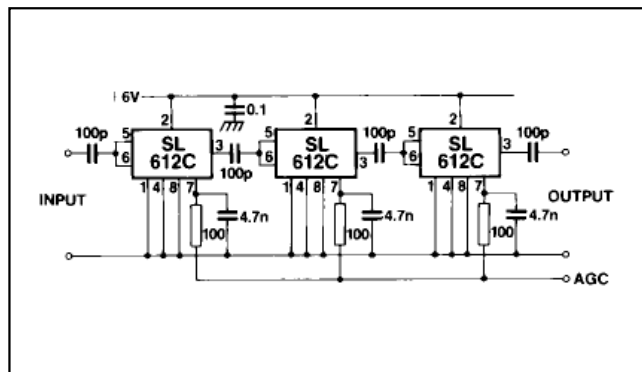

Fig.9 IF amplifier using SL612C



HEADQUARTERS OPERATIONS
GEC PLESSEY SEMICONDUCTORS
Cheney Manor, Swindon,
Wiltshire SN2 2QW, United Kingdom.
Tel: (0793) 518000
Fax: (0793) 518411

GEC PLESSEY SEMICONDUCTORS
P.O. Box 660017
1500 Green Hills Road,
Scotts Valley, California 95067-0017,
United States of America.
Tel: (408) 438 2900
Fax: (408) 438 5576

CUSTOMER SERVICE CENTRES

- **FRANCE & BENELUX** Les Ulis Cedex Tel: (1) 64 46 23 45 Tx: 602858F
Fax : (1) 64 46 06 07
- **GERMANY** Munich Tel: (089) 3609 06-0 Tx: 523980 Fax : (089) 3609 06-55
- **ITALY** Milan Tel: (02) 66040867 Fax: (02) 66040993
- **JAPAN** Tokyo Tel: (03) 3296-0281 Fax: (03) 3296-0228
- **NORTH AMERICA Integrated Circuits and Microwave Products** Scotts Valley, USA
Tel (408) 438 2900 Fax: (408) 438 7023.
Hybrid Products, Farmingdale, USA Tel (516) 293 8686
Fax: (516) 293 0061.
- **SOUTH EAST ASIA** Singapore Tel: (65) 3827708 Fax: (65) 3828872
- **SWEDEN** Stockholm, Tel: 46 8 702 97 70 Fax: 46 8 640 47 36
- **UNITED KINGDOM & SCANDINAVIA**
Swindon Tel: (0793) 518510 Tx: 444410 Fax : (0793) 518582

These are supported by Agents and Distributors in major countries world-wide.

© GEC Plessey Semiconductors 1993 Publication No. DS3630 Issue No. 1.1 June 1993

This publication is issued to provide information only which (unless agreed by the Company in writing) may not be used, applied or reproduced for any purpose nor form part of any order or contract nor to be regarded as a representation relating to the products or services concerned. No warranty or guarantee express or implied is made regarding the capability, performance or suitability of any product or service. The Company reserves the right to alter without prior knowledge the specification, design or price of any product or service. Information concerning possible methods of use is provided as a guide only and does not constitute any guarantee that such methods of use will be satisfactory in a specific piece of equipment. It is the user's responsibility to fully determine the performance and suitability of any equipment using such information and to ensure that any publication or data used is up to date and has not been superseded. These products are not suitable for use in any medical products whose failure to perform may result in significant injury or death to the user. All products and materials are sold and services provided subject to the Company's conditions of sale, which are available on request.



**For more information about all Zarlink products
visit our Web Site at
www.zarlink.com**

Information relating to products and services furnished herein by Zarlink Semiconductor Inc. trading as Zarlink Semiconductor or its subsidiaries (collectively "Zarlink") is believed to be reliable. However, Zarlink assumes no liability for errors that may appear in this publication, or for liability otherwise arising from the application or use of any such information, product or service or for any infringement of patents or other intellectual property rights owned by third parties which may result from such application or use. Neither the supply of such information or purchase of product or service conveys any license, either express or implied, under patents or other intellectual property rights owned by Zarlink or licensed from third parties by Zarlink, whatsoever. Purchasers of products are also hereby notified that the use of product in certain ways or in combination with Zarlink, or non-Zarlink furnished goods or services may infringe patents or other intellectual property rights owned by Zarlink.

This publication is issued to provide information only and (unless agreed by Zarlink in writing) may not be used, applied or reproduced for any purpose nor form part of any order or contract nor to be regarded as a representation relating to the products or services concerned. The products, their specifications, services and other information appearing in this publication are subject to change by Zarlink without notice. No warranty or guarantee express or implied is made regarding the capability, performance or suitability of any product or service. Information concerning possible methods of use is provided as a guide only and does not constitute any guarantee that such methods of use will be satisfactory in a specific piece of equipment. It is the user's responsibility to fully determine the performance and suitability of any equipment using such information and to ensure that any publication or data used is up to date and has not been superseded. Manufacturing does not necessarily include testing of all functions or parameters. These products are not suitable for use in any medical products whose failure to perform may result in significant injury or death to the user. All products and materials are sold and services provided subject to Zarlink's conditions of sale which are available on request.

Purchase of Zarlink's I²C components conveys a licence under the Philips I²C Patent rights to use these components in an I²C System, provided that the system conforms to the I²C Standard Specification as defined by Philips.

Zarlink and the Zarlink Semiconductor logo are trademarks of Zarlink Semiconductor Inc.

Copyright 2002, Zarlink Semiconductor Inc. All Rights Reserved.

TECHNICAL DOCUMENTATION - NOT FOR RESALE
