

***THIS DOCUMENT IS FOR MAINTENANCE
PURPOSES ONLY AND IS NOT
RECOMMENDED FOR NEW DESIGNS***

SL523

100MHz DUAL WIDEBAND LOG AMPLIFIER

The SL523B and C are wideband amplifiers for use in successive detection logarithmic IF strips operating at centre frequencies between 10 and 100MHz. They are pin compatible with the SL521 series of logarithmic amplifiers and comprise two amplifiers internally connected in cascade. Small signal voltage gain is 24dB and an internal detector with an accurate logarithmic characteristic over a 20dB range produces a maximum Output of 2.1 mA. A strip of SL523s can be directly coupled and decoupling is provided on each amplifier. RF limiting occurs at an input voltage of 25mV RMS but the device will withstand input voltages up to 1.8V RMS without damage.

The device is also available as the 5962-89803 which has guaranteed operation over the full Military Temperature Range and is screened to MIL-STD-883 Class B. Data is available separately.

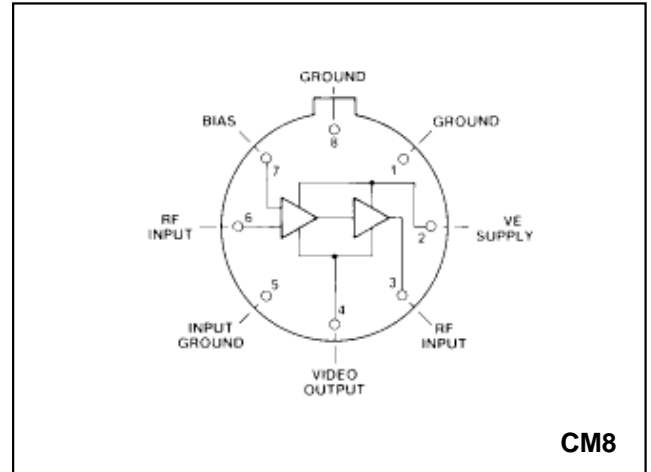

Fig.1 Pin connections (view from beneath)

FEATURES

- Small Size/Weight
- Low Power Consumption
- Readily Cascadable
- Accurate Logarithmic Detector Characteristic

ABSOLUTE MAXIMUM RATINGS (Non-simultaneous)

Storage temperature range	-65°C to +150°C
Operating temperature range	-55°C to +125°C
Thermal resistance	
Chip-to-ambient	200°C/W
Chip-to-case	52°C/W
Maximum instantaneous voltage at video output	+12V
Supply voltage	+9V

QUICK REFERENCE DATA

- Small Signal Voltage Gain: 24dB
- Detector Output Current: 21mA
- Noise Figure: 4dB
- Frequency Range: 10-100MHz
- Supply Voltage +6V
- Supply Current 30mA

ORDERING INFORMATION

- SL523 B CM
- SL523 C CM
- SL523 CB CM
- 5962-89803 (SMD)

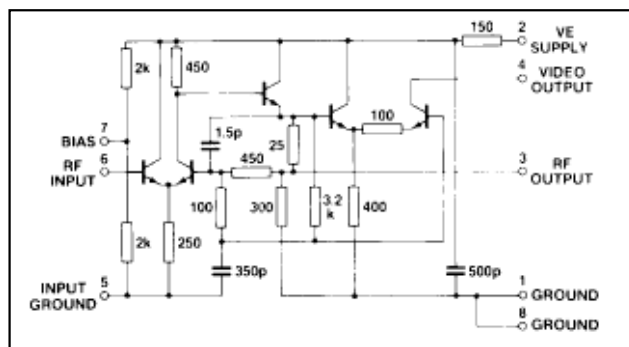

Fig.2 Circuit diagram (one amplifier)

SL523

ELECTRICAL CHARACTERISTICS

These characteristics are guaranteed over the following conditions (unless otherwise stated)

Ambient temperature = 22°C ± 2°C; Source impedance = 10Ω; Supply voltage = +6V; Load impedance = 8pF; Frequency = 60MHz; DC connection between Pin 6 and 7

Characteristic	Circuits	Value			Units	Conditions
		Min.	Typ.	Max.		
Small signal voltage gain	B	22.6	24	25.4	dB	} Frequency = 30MHz
	C	22	24	26	dB	
Small signal voltage gain	B	22	24	26	dB	} Frequency = 60MHz
	C	21.4	24	26.6	dB	
Gain variation (set of 8)			0.5	0.75	dB	Frequency = 60MHz
Upper cut-off frequency	B, C	120	150		MHz	
Lower cut-off frequency	B, C		10	15	MHz	
Propagation delay	B, C		4		ns	
Maximum rectified video output current	B	1.9	2.1	2.3	mA	
	C	1.8	2.1	2.4	mA	
Maximum input signal before overload	B, C	1.8	1.9		V RMS	See note below
Noise figure			4	5.25	dB	Source impedance 450Ω
Supply current	B	25	30	36	mA	
	C	23	30	38	mA	
Maximum RF output voltage	B, C		1.2		V p-p	

Note:- Overload occurs when the input signal reaches a level sufficient to forward bias the base-collector junction to the input transistor on peaks

OPERATING NOTES

The amplifier is designed to be directly coupled (see Fig.5)

The fourth stage in an untuned cascade will give full output on the broad band noise generated by the first stage.

Noise may be reduced by inserting a single tuned circuit in the chain. As there is a large mismatch between stages a simple shunt or series circuit cannot be used. The network chosen must give unity voltage gain at resonance to avoid distorting the log law. The typical value for input impedance is 500Ω in parallel with 5pF and the output impedance is typically 30Ω.

Although a 1nF supply line decoupling capacitor is included in the can an extra capacitor is required when the amplifiers are cascaded. Minimum values for this capacitor are: 2 stages - 3nF, 3 or more stages 30nF

In cascades of 3 or more stages care must be taken to avoid oscillations caused either by inductance common to the input and output earths of the strip or by feedback along the common video line. The use of a continuous earth plane will avoid earth inductance problems and a common base amplifier in the video line isolating the first two stages as shown in Fig 6 will eliminate feedback on the video line

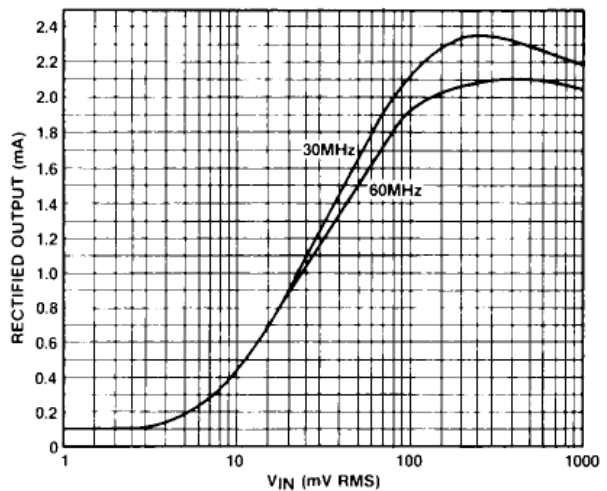

Fig.3 Rectified output current v. input signal (typical)

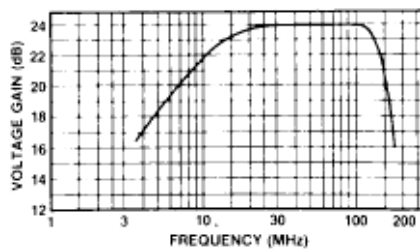

Fig.4 Voltage gain v. frequency (typical)

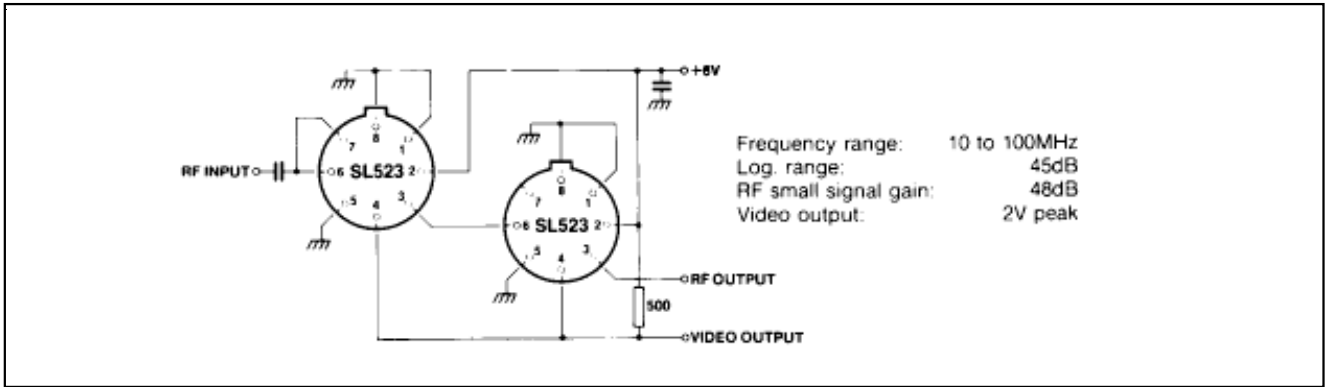

Fig.5 Simple log. IF strip

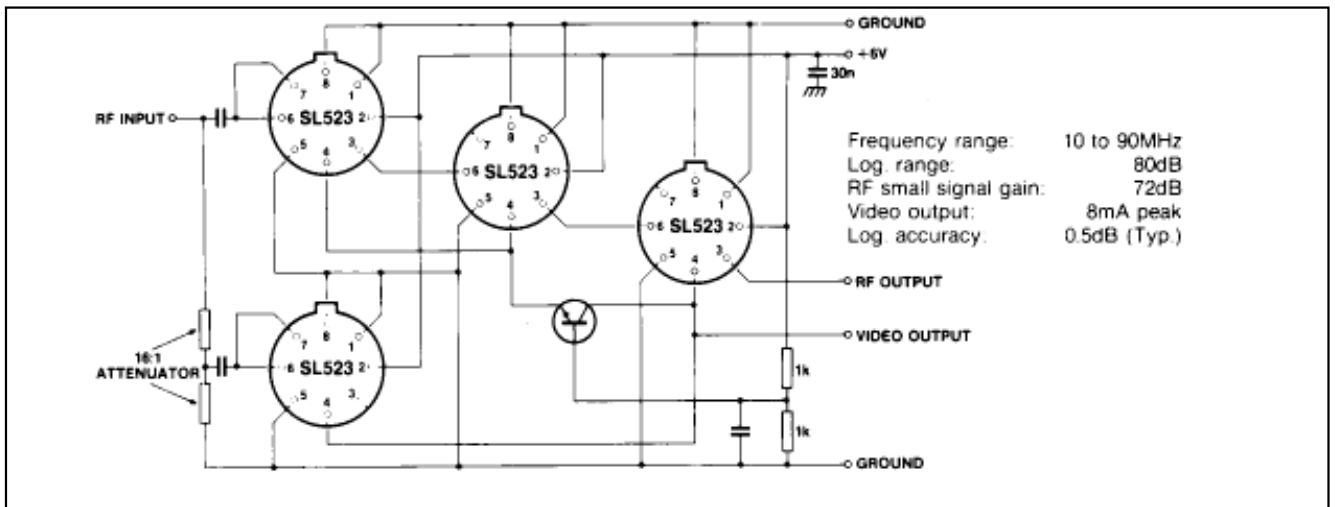

Fig.6 Wide dynamic range log. IF strip

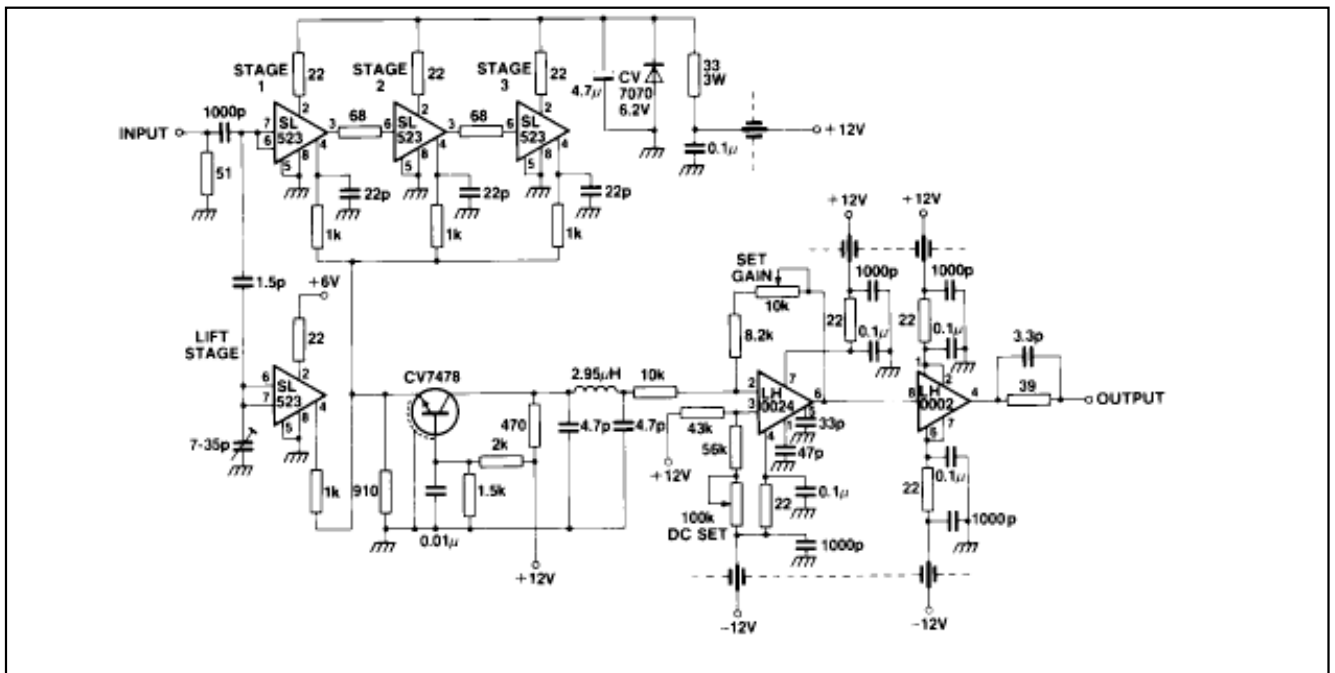

Fig.7 Wideband logarithmic amplifier

TYPICAL PERFORMANCE

Unselected SL523B devices were tested in a wideband logarithmic amplifier. described in RSRE Memo No 3027 and shown in Fig 7

The amplifier consists of six logarithmic stages and two 'lift' stages, giving an overall dynamic range of greater than 80dB The response and error curves were plotted on an RHG Log Test Set and bandwidth measurements were made with a Telonic Sweeper and Tektronix oscilloscope

Fig 8 shows the dynamic range error curve and f frequency response obtained. The stage gains of the SL523 devices used were as shown in Table 1

Stages	fo (MHz)	Gain (dB)	Max. Deviation (dB)
1	60	24.1 23	0.235
2	60	24.089	
3	60	23.888	
Lift	60	24.086	

Table 1 Stage gains of SL523 used in performance tests

The input v output characteristic (Fig.8a) is calibrated at 10dB/cm in the X axis and 1V/cm in the Y axis 80dB of dynamic range was attained

The error characteristic (Fig 8b) is calibrated at 10dB/cm in the X axis and 1dB/cm in the Y axis; this shows the error between the log input v. output characterisct and a mean straight line and shows that a dynamic range of 80dB was obtained with an accuracy of ± 0.5 dB

As a comparison, the log amplifier of Fig 7 was constructed with randomly selected SL521 Bs (two SL521 Bs replacing each SL523B). Again, a dynamic response of 80dB was obtained (Fig 9a) with an accuracy of 1 0 75dB (Fig.9b)

Bandwidth curves are shown in Figs.8c and 9c, where the amplitude scale is 2dB/cm, with frequency markers at 10MHz intervals from 20 to 100MHz Using SL523Bs (Fig.8c), the frequency response at 90MHz is 4dB down on maximum and there is a fall-off in response after 50MHz Fig 9c shows that the frequency response of the amplifier falls off more gradually after 40MHz but again the response at 90MHz is 4dB down on maximum

These tests show that the SL523 is a very successful dual stage log amplifier element and, since it is pin-compatible with the SL521 enables retrofit to be carried out in existing log amplifiers It will be of greatest benefit however, in the design of new log amplifiers, enabling very compact units to be realised with a much shorter summation line

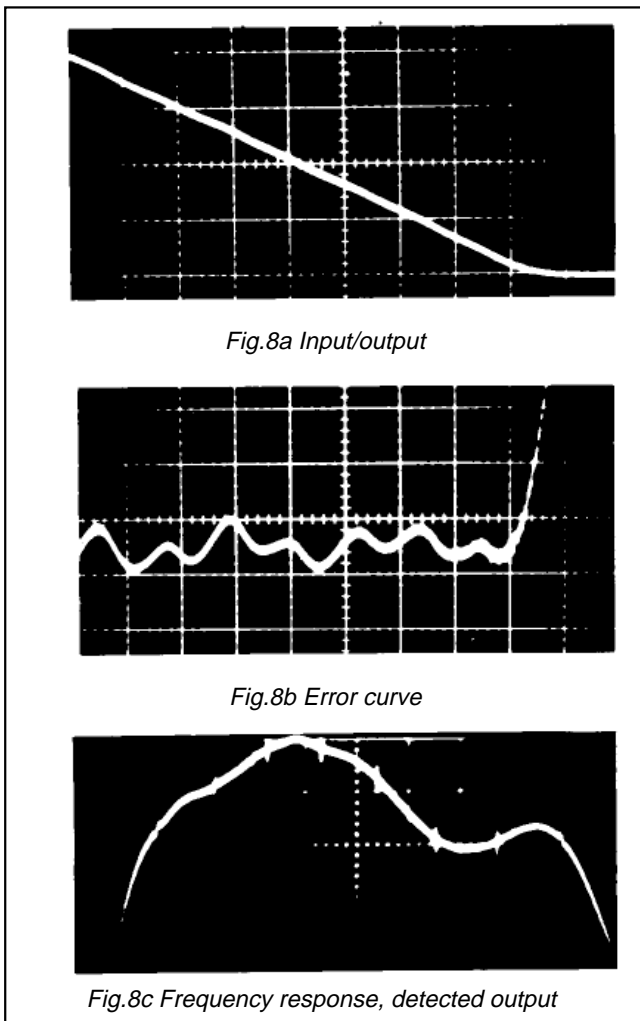

Fig.8 Characteristics of circuit shown in Fig 7 using SL523Bs

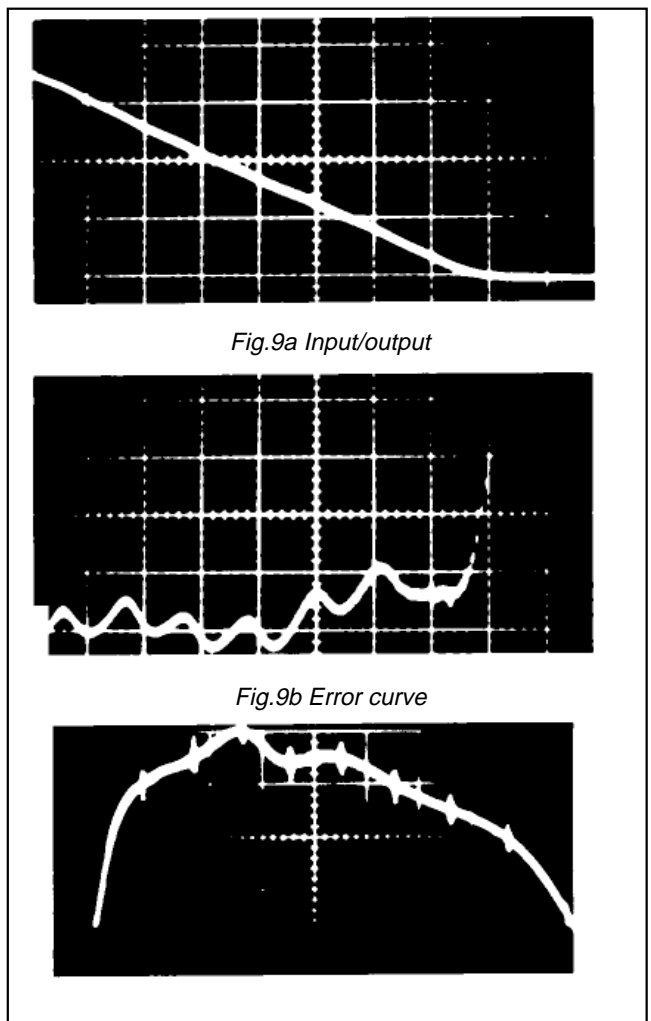

Fig.9 Characteristics of circuit shown in Fig 7 using SL523Bs



HEADQUARTERS OPERATIONS
GEC PLESSEY SEMICONDUCTORS
Cheney Manor, Swindon,
Wiltshire SN2 2QW, United Kingdom.
Tel: (0793) 518000
Fax: (0793) 518411

GEC PLESSEY SEMICONDUCTORS
P.O. Box 660017
1500 Green Hills Road,
Scotts Valley, California 95067-0017,
United States of America.
Tel: (408) 438 2900
Fax: (408) 438 5576

CUSTOMER SERVICE CENTRES

- **FRANCE & BENELUX** Les Ulis Cedex Tel: (1) 64 46 23 45 Fax : (1) 64 46 06 07
- **GERMANY** Munich Tel: (089) 3609 06-0 Fax : (089) 3609 06-55
- **ITALY** Milan Tel: (02) 66040867 Fax: (02) 66040993
- **JAPAN** Tokyo Tel: (03) 5276-5501 Fax: (03) 5276-5510
- **NORTH AMERICA** Scotts Valley, USA Tel (408) 438 2900 Fax: (408) 438 7023.
- **SOUTH EAST ASIA** Singapore Tel: (65) 3827708 Fax: (65) 3828872
- **SWEDEN** Stockholm, Tel: 46 8 702 97 70 Fax: 46 8 640 47 36
- **UK, EIRE, DENMARK, FINLAND & NORWAY**
Swindon Tel: (0793) 518510 Fax : (0793) 518582

These are supported by Agents and Distributors in major countries world-wide.

© GEC Plessey Semiconductors 1994

This publication is issued to provide information only which (unless agreed by the Company in writing) may not be used, applied or reproduced for any purpose nor form part of any order or contract nor to be regarded as a representation relating to the products or services concerned. No warranty or guarantee express or implied is made regarding the capability, performance or suitability of any product or service. The Company reserves the right to alter without prior knowledge the specification, design or price of any product or service. Information concerning possible methods of use is provided as a guide only and does not constitute any guarantee that such methods of use will be satisfactory in a specific piece of equipment. It is the user's responsibility to fully determine the performance and suitability of any equipment using such information and to ensure that any publication or data used is up to date and has not been superseded. These products are not suitable for use in any medical products whose failure to perform may result in significant injury or death to the user. All products and materials are sold and services provided subject to the Company's conditions of sale, which are available on request.



**For more information about all Zarlink products
visit our Web Site at
www.zarlink.com**

Information relating to products and services furnished herein by Zarlink Semiconductor Inc. trading as Zarlink Semiconductor or its subsidiaries (collectively "Zarlink") is believed to be reliable. However, Zarlink assumes no liability for errors that may appear in this publication, or for liability otherwise arising from the application or use of any such information, product or service or for any infringement of patents or other intellectual property rights owned by third parties which may result from such application or use. Neither the supply of such information or purchase of product or service conveys any license, either express or implied, under patents or other intellectual property rights owned by Zarlink or licensed from third parties by Zarlink, whatsoever. Purchasers of products are also hereby notified that the use of product in certain ways or in combination with Zarlink, or non-Zarlink furnished goods or services may infringe patents or other intellectual property rights owned by Zarlink.

This publication is issued to provide information only and (unless agreed by Zarlink in writing) may not be used, applied or reproduced for any purpose nor form part of any order or contract nor to be regarded as a representation relating to the products or services concerned. The products, their specifications, services and other information appearing in this publication are subject to change by Zarlink without notice. No warranty or guarantee express or implied is made regarding the capability, performance or suitability of any product or service. Information concerning possible methods of use is provided as a guide only and does not constitute any guarantee that such methods of use will be satisfactory in a specific piece of equipment. It is the user's responsibility to fully determine the performance and suitability of any equipment using such information and to ensure that any publication or data used is up to date and has not been superseded. Manufacturing does not necessarily include testing of all functions or parameters. These products are not suitable for use in any medical products whose failure to perform may result in significant injury or death to the user. All products and materials are sold and services provided subject to Zarlink's conditions of sale which are available on request.

Purchase of Zarlink's I²C components conveys a licence under the Philips I²C Patent rights to use these components in an I²C System, provided that the system conforms to the I²C Standard Specification as defined by Philips.

Zarlink and the Zarlink Semiconductor logo are trademarks of Zarlink Semiconductor Inc.

Copyright 2002, Zarlink Semiconductor Inc. All Rights Reserved.

TECHNICAL DOCUMENTATION - NOT FOR RESALE
