

HITACHI

KAOHSIUNG HITACHI
ELECTRONICS CO.,LTD
P.O. BOX 26-27
2,13TH EAST ST. K.E.P.Z.
KAOHSIUNG TAIWAN R.O.C.
TEL:(07) 8215811 (7 LINE)
FAX:(07) 821-5815

FOR MESSRS : _____

DATE : Jun.17,2004

CUSTOMER'S ACCEPTANCE SPECIFICATIONS TX09D50VM1CCA CONTENTS

No.	ITEM	SHEET No.	PAGE
1	COVER	7B64PS 2701-TX09D50VM1CCA-1	1-1/1
2	RECORD OF REVISION	7B64PS 2702-TX09D50VM1CCA-1	2-1/1
3	GENERAL DATA	7B64PS 2703-TX09D50VM1CCA-1	3-1/1
4	ABSOLUTE MAXIMUM RATINGS	7B64PS 2704-TX09D50VM1CCA-1	4-1/2~2/2
5	ELECTRICAL CHARACTERISTICS	7B64PS 2705-TX09D50VM1CCA-1	5-1/2~2/2
6	OPTICAL CHARACTERISTICS	7B64PS 2706-TX09D50VM1CCA-1	6-1/2~2/2
7	BLOCK DIAGRAM	7B64PS 2707-TX09D50VM1CCA-1	7-1/1
8	INTERFACE TIMING CHART	7B64PS 2708-TX09D50VM1CCA-1	8-1/5~5/5
9	DIMENSIONAL OUTLINE	7B63PS 2709-TX09D50VM1CCA-1	9-1/1
10	APPEARANCE STANDARD	7B64PS 2710-TX09D50VM1CCA-1	10-1/4~4/4
11	PRECAUTION IN DESIGN	7B64PS 2711-TX09D50VM1CCA-1	11-1/3~3/3
12	DESIGNATION OF LOT MARK	7B64PS 2712-TX09D50VM1CCA-1	12-1/1
13	PRECAUTION FOR USE	7B64PS 2713-TX09D50VM1CCA-1	13-1/1

*When product will be discontinued, customer will be informed by HITACHI with twelve months prior announcement.

ACCEPTED BY: _____

PROPOSED BY: Dan Cheng

RECORD OF REVISION

DATE	SHEET No.	SUMMARY

3.GENERAL DATA

(1) Part Name	TX09D50VM1CCA
(2) Module Dimensions	64.0(W)mm x 86.0(H)mm x (8.05)
(3) Effective Display Area	53.64(W)mm x 71.52(H)mm (Diagonal:9cm)
(4) Dot Pitch	0.0745mm x 3(R,G,B)(W) x 0.2235(H)mm
(5) Resolution	240 x 3(R,G,B)(W) x 320 (H) dots
(6) Color Pixel Arrangement	R,G,B Vertical stripe
(7) LCD Type	Transmissive Color TFT LCD (Normally White)
(8) Display Type	Active Matrix
(9) Number of Colors	262 ^k Colors (R,G,B 6 Bit Parallel)
(10) Backlight	Light Emitting Diode (LED) x 6
(11) Weight	(T.B.D) typ.
(12) Interface	40 pin C-MOS

4. ABSOLUTE MAXIMUM RATINGS

4.1 ELECTRICAL ABSOLUTE MAXIMUM RATINGS OF LCD

VSS=0V

ITEM		SYMBOL	MIN.	MAX.	UNIT	COMMENT
Power Supply for Logic		VDD	-0.3	4.0	V	
Input Voltage		VI	-0.2	VDD+0.2		(Note 1)
Input Current		li	0	1	A	
Static Electricity		VESD0	-	±100	V	(Note 2,3)
		VESD1	-	(8)	kV	(Note 2,4)
LED	Forward Current	IF	-	30	mA	(Note 5)
	Pulse Forward Current	IFP	-	100	mA	(Note 6)
	Reverse Voltage	VR	-	5	V	

Note 1 : DTMG, DCLK, RD0~RD5, GD0~GD5, BD0~BD5.

Note 2 : 200pF-0Ω 25°C -70%RH

Note 3 : Interface Pin Connector.

Note 4 : The surface of metal bezel and LCD panel.

Note 5 :

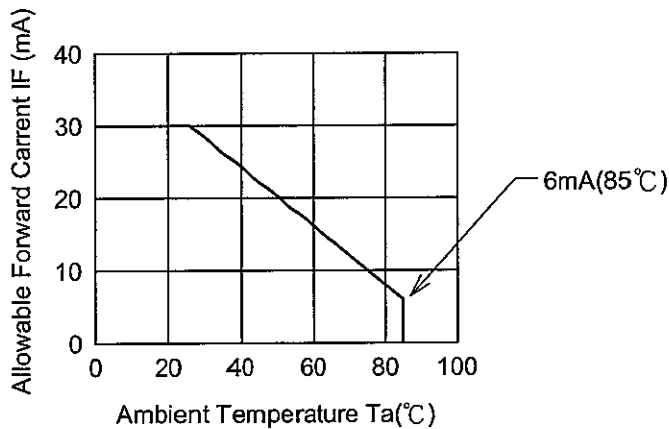

Note 6 : IFP Conditions : pulse width ≤ 10ms and Duty ≤ 5 %

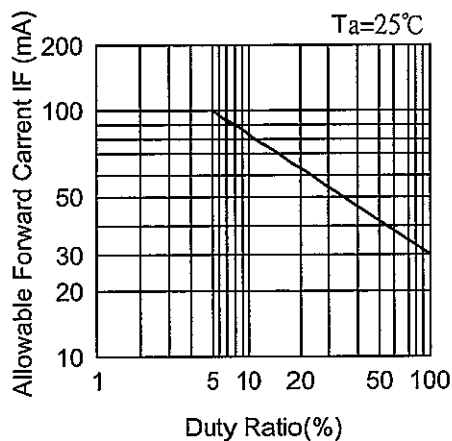

4.2 ELECTRICAL ABSOLUTE MAXIMUM RATINGS OF TOUCH PANEL

ITEM	SPECIFICATION	UNIT	CONDITION	REMARKS
Supply Voltage	7.0	V	DC	
Endurance Voltage	25	V	DC	(Note 1)

Note 1 : Waiting 1 minute.

4.3 ENVIRONMENTAL ABSOLUTE MAXIMUM RATINGS

ITEM	OPERATING		STORAGE		REMARKS
	Min.	Max.	Min.	Max.	
Ambient Temperature	-10°C	50°C	-20°C	60°C	(Note 1)
Humidity	(Note 2)		(Note 2)		Without condensation
Vibration	-	(2.45)m/s ² (0.25G)	-	(11.76)m/s ² (1.2G)	(Note 4 , 5)
Shock	-	(29.4)m/s ² (3G)	-	(490)m/s ² (50G)	(Note 4 , 6)
Corrosive Gas	Not Acceptable		Not Acceptable		

Note 1 : Background color changes slightly depending on ambient temperature.

This phenomenon is reversible.

Note 2 : $T_a \leq 40^\circ\text{C}$: 85%RH max.

$T_a > 40^\circ\text{C}$: Absolute humidity must be lower than the humidity of 85%RH at 40°C.

Note 3 : Please attach not to add the stress by temperature change and mechanical stress to LCM.

Note 4 : It should be fixed and assembled into the customer's application when test. And the test condition should be followed HITACHI test method.

After finished testing , the module should be normal operating. But it is for reference only.

Note 5 : 15Hz ~ 100Hz (except resonance frequency)

Note 6 : $\pm X, \pm Y, \pm Z$, 10ms.

5. ELECTRICAL CHARACTERISTICS

5.1 ELECTRICAL CHARACTERISTICS OF LCD

Ta=25°C, VSS=0V

ITEM	SYMBOL	CONDITION	MIN.	TYP.	MAX.	UNIT
Power Supply Voltage	VDD	-	3.0	3.3	3.6	V
Input voltage for logic (note 1)	VI	"H" level	1.7	-	VDD	V
		"L" level	VSS	-	0.7	
Power Supply Current (note 2)	IDD	VDD-VSS=3.3V	-	(T.B.D)	-	mA
Vsync Frequency	fV	-	-	60	-	Hz
Hsync Frequency	fH	-	-	(19.5)	-	kHz
DCLK Frequency	fCLK	-	-	(5.33)	-	MHz

Note 1 : DTMG, DCLK, RD0~RD5, GD0~GD5, BD0~BD5.

Note 2 : fV=60Hzm, Ta=25°C, Pattern used as display pattern : All Black.

Note 3 : Need to made sure of flickering and rippling of display when setting the frame frequency in your set.

5.2 ELECTRICAL CHARACTERISTICS OF BACK LIGHT

ITEM	SYMBOL	CONDITION	MIN.	TYP.	MAX.	UNIT	REMARKS
LED Input Voltage	VF	IF=20mA	-	3.6	4.0	V	LED / Part
LED Forward Current	IF	-	-	20	25	mA	LED / Part
LED Reverse Current	IR	VR=5V	-	-	50	μA	LED / Part

5.3 ELECTRICAL CHARACTERISTICS OF TOUCH PANEL

ITEM		SPECIFICATION	UNIT
Resistance between Terminal	xR - xL	200 - 650	ohm
	yU - yL	250 - 500	ohm
Insulance Resistance (Note 1)	x - y	10M min.	ohm
Linearity (Note 2,3)	x	1.5 max.	%
	y	1.5 max.	%
Chattering		10 max.	ms

Note 1 : Operating Voltage 25V DC.

Note 2 : Test Condition.

(a) Y axis linearity testing method (with tip radius 0.8, polaycetal pen). $V_{xL-xR}=5V$, $V_{OUT}=V_{yU}$.

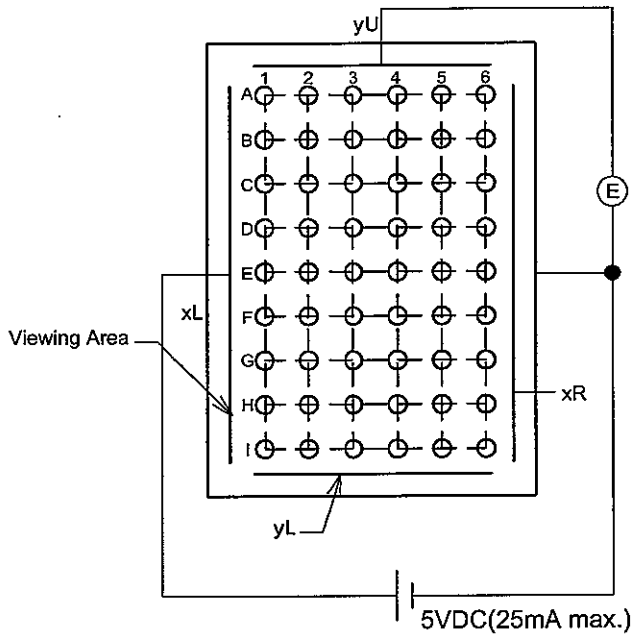

(b) X axis linearity method $V_{yU-yL}=5V$, $V_{OUT}=V_{xL}$.

Note 3 : Calculation

(a) Y axis linearity

$$\text{Linearity} = \frac{\Delta E \text{ max.}}{EA1 - EA6} \times 100(\%)$$

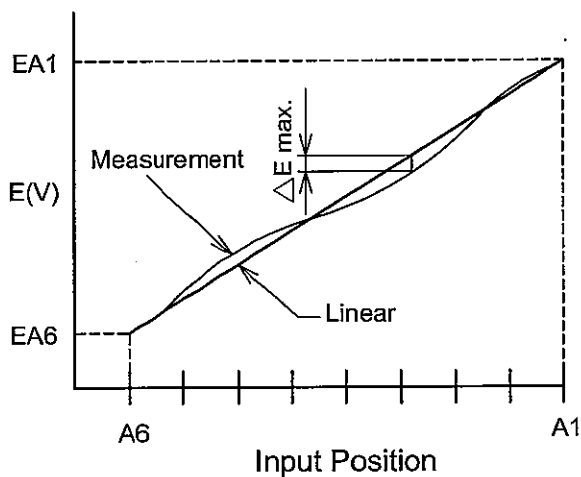

5.4 MECHANICAL CHARACTERISTICS OF TOUCH PANEL

ITEM	SPECIFICATION	UNIT	REMARKS
Pen Input Pressure	-	N	R0.8mm Polyacetal pen (Note 4)
	0.1 - 1.3		
Surface Hardness	3H min.	-	JIS K 5400

6. OPTICAL CHARACTERISTICS

6.1 OPTICAL CHARACTERISTICS OF LCD (BACKLIGHT ON , ON TOUCH PANEL)

Ta=25°C

ITEM	SYMBOL	CONDITION	MIN.	TYP.	MAX.	UNIT	NOTE	
Brightness	B	$\phi=0^\circ \theta=0^\circ$	-	(100)	-	cd/m ²	(1,3)	
Uniformity	-	$\phi=0^\circ \theta=0^\circ$	(70)	-	-	%	(2,3)	
Viewing Angle	$\phi 2-\phi 1$	$\theta=0^\circ, K \geq 2.0$	-	(130)	-	deg	(4,5)	
		$\theta=90^\circ, K \geq 2.0$	-	(120)	-			
Contrast Ratio	K	$\phi=0^\circ \theta=0^\circ$	(180)	(300)	-	-	(3)	
Response Time (rise-fall)	tr+tf	$\phi=0^\circ \theta=0^\circ$	-	(35)	70	ms	(7)	
Color Tone (Primary Color)	Red	x	$\phi=0^\circ \theta=0^\circ$	-	(0.60)	-	-	(3)
		y		-	(0.34)	-	-	
	Green	x		-	(0.33)	-	-	
		y		-	(0.55)	-	-	
	Blue	x		-	(0.14)	-	-	
		y		-	(0.13)	-	-	
	White	x		-	(0.32)	-	-	
		y		-	(0.34)	-	-	

(Measurement condition : HITACHI standard)
(Note 4~7) : See page 6-2/2

Note 1 : Driving Condition

Display Pattern : White Raster
LED Current : 20mA / Part
Measurement of the following
9 places on the display.

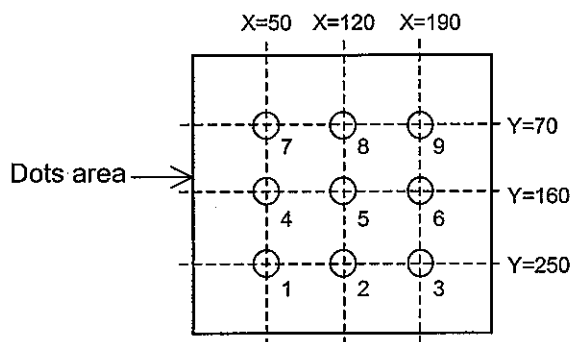

Note 2 : Definition of the brightness tolerance

$$\left(\frac{\text{Min. brightness}}{\text{Max. brightness}} \right) \times 100$$

Note 3 : Measurement Condition

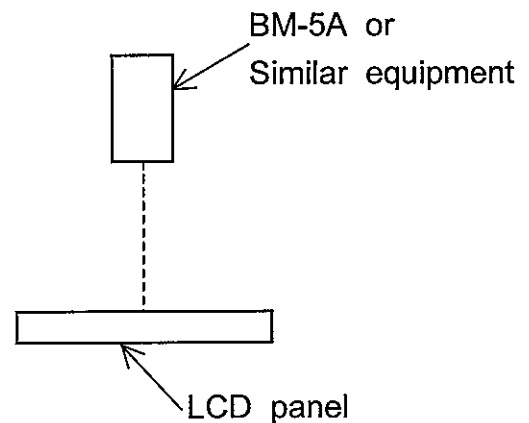

Note 4 : Definition of θ and ϕ
(Normal)
Viewing direction

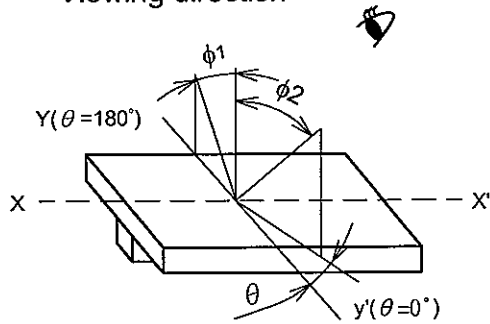

Note 6 : Definition of contrast "K"

$$K = \frac{\text{White Brightness}}{\text{Black Brightness}}$$

Note 5 : Definition of Viewing angle ϕ_1 and ϕ_2

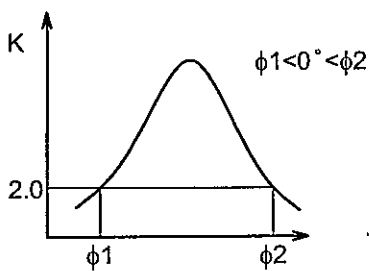

Contrast ratio "K" vs Viewing angle " ϕ "

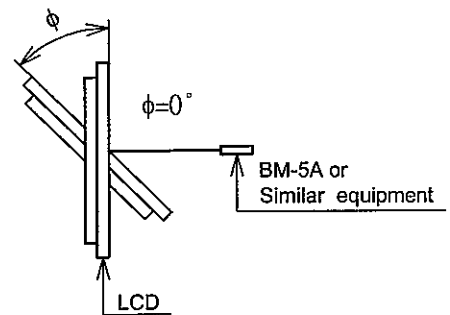

Note 7 : Definition Optical Response Time

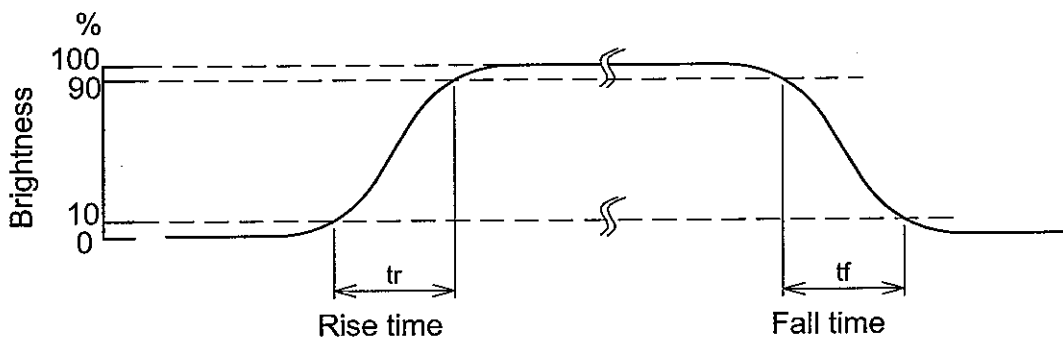
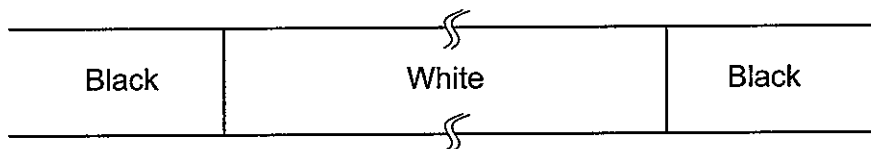

7.BLOCK DIAGRAM

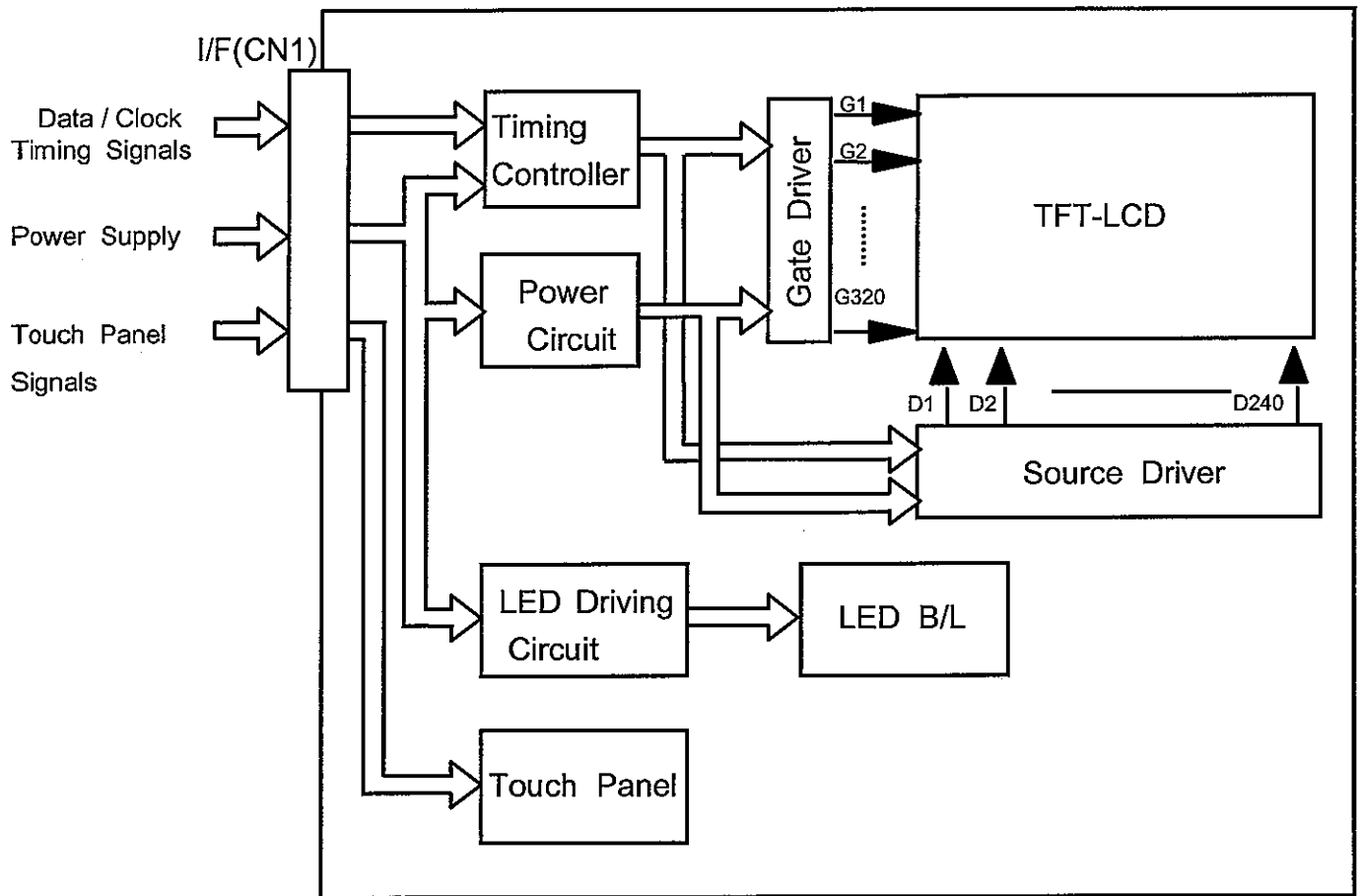

8. INTERFACE TIMING

8.1 INTERFACE TIMING

	MIN.	TYP.	MAX.	UNIT	SYMBOL
Vertical Total	-	(327)	-	Line	T0
Vertical Sync Width	1	1	-	Line	T1
Vertical Sync Start	-	(322)	-	Line	T2
Vertical Sync End	-	(323)	-	Line	T3
Vertical Blank Time	5	(7)	-	Line	T4
Vertical Display End	-	(320)	-	Line	T5
Horizontal Total	-	(273)	-	Pixel Clock	T6
Horizontal Sync Width	-	(5)	-	Pixel Clock	T7
Horizontal Sync Start	-	(251)	-	Pixel Clock	T8
Horizontal Sync End	-	(256)	-	Pixel Clock	T9
Horizontal Blank Time	-	(33)	-	Pixel Clock	T10
Horizontal Display End	-	(240)	-	Pixel Clock	T11

Note : Vertical total should be set to odd.

8.2 Timing Chart

(Data is latched negative edge trigger of DCLK)

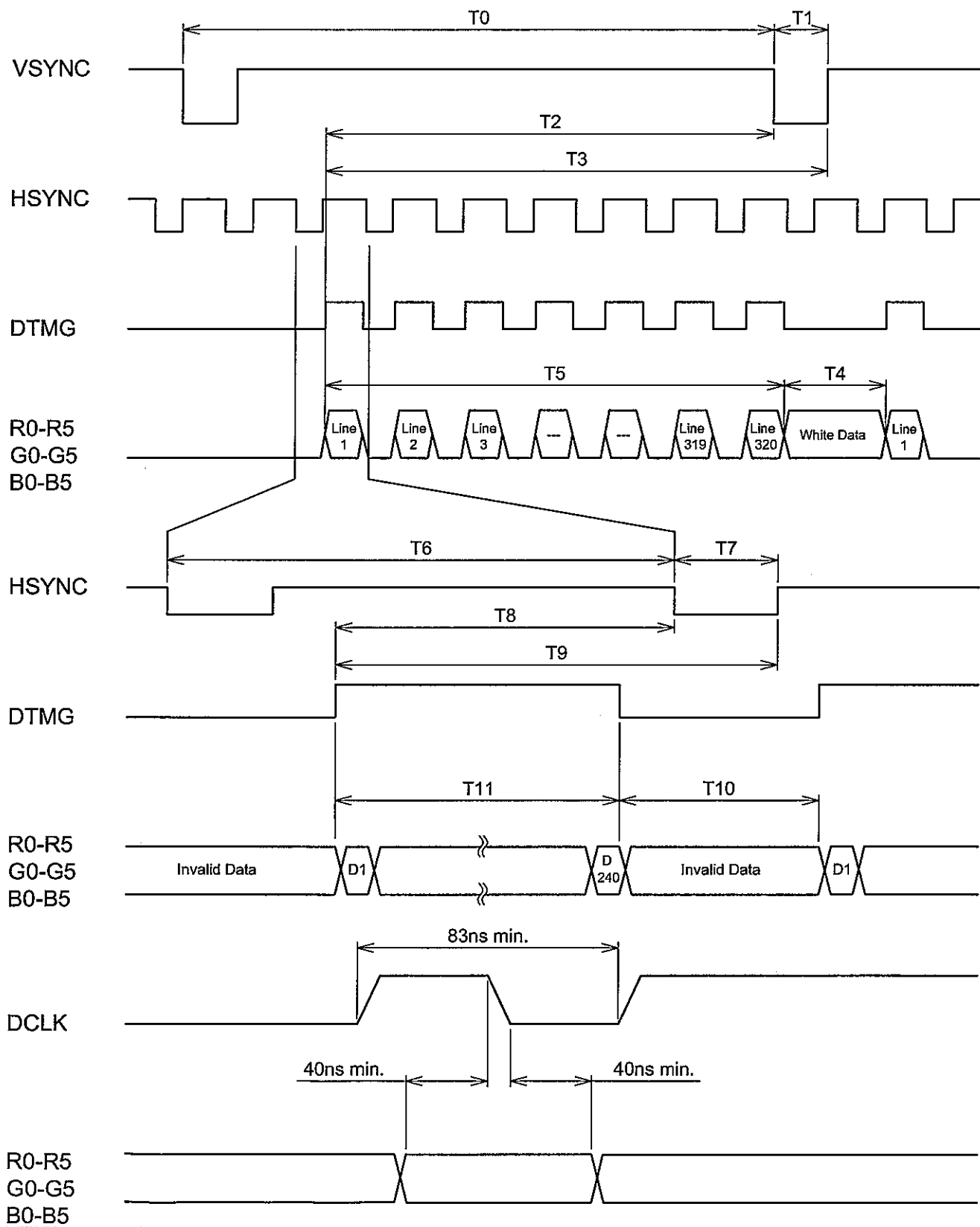

8.3 POWER ON/OFF SEQUEUCE

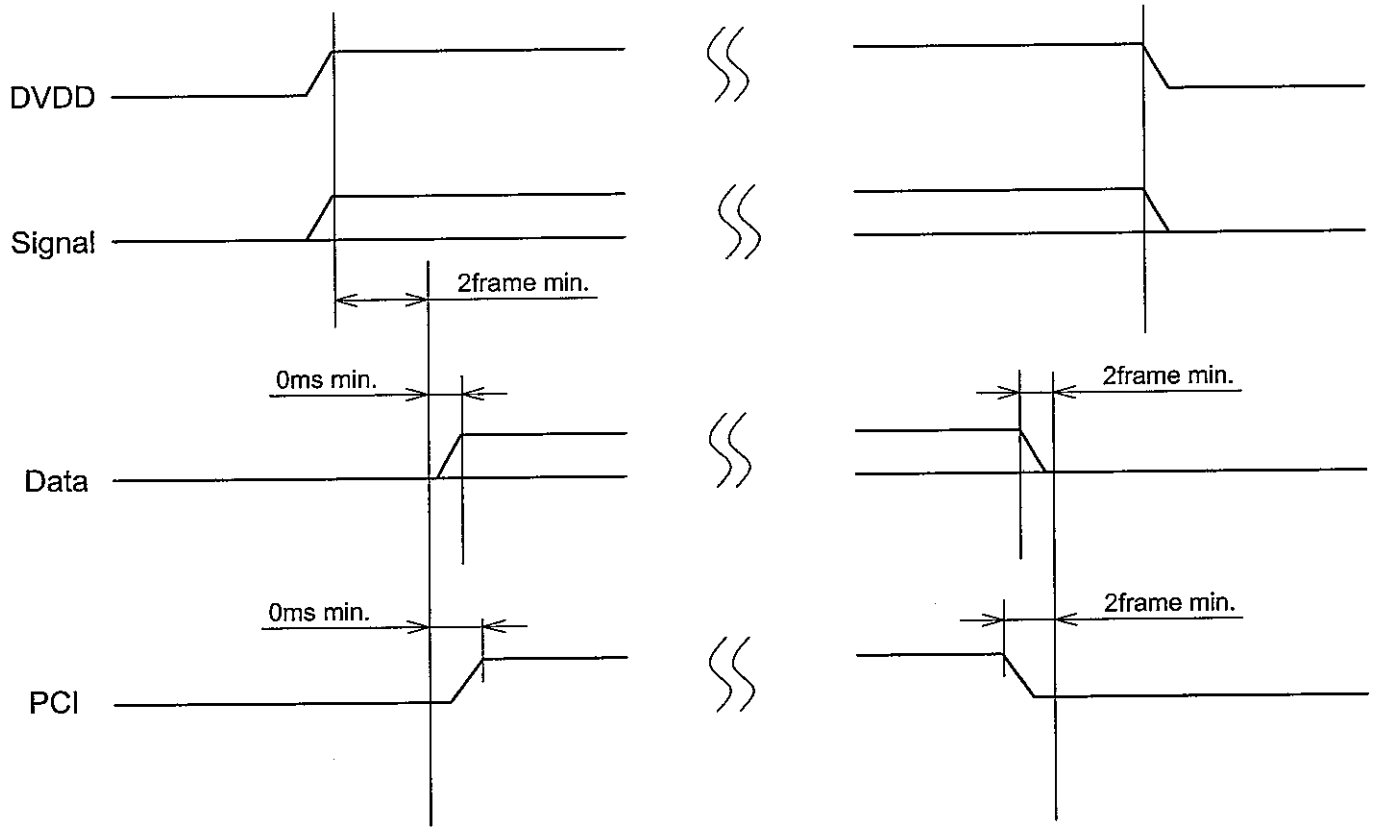

8.4 RELATIONSHIP BETWEEN DISPLAYED COLOR AND INPUT DATA

	COLOR & GRAY SCALE	GRAY SCALE LEVELS	DATA SIGNAL																	
			R0	R1	R2	R3	R4	R5	G0	G1	G2	G3	G4	G5	B0	B1	B2	B3	B4	B5
Basic Color	Black	-	0	0	0	0	0	0	0	0	0	0	0	0	0	0	0	0	0	0
	Blue	-	0	0	0	0	0	0	0	0	0	0	0	0	1	1	1	1	1	1
	Green	-	0	0	0	0	0	0	1	1	1	1	1	1	0	0	0	0	0	0
	Cyan	-	0	0	0	0	0	0	1	1	1	1	1	1	1	1	1	1	1	1
	Red	-	1	1	1	1	1	1	0	0	0	0	0	0	0	0	0	0	0	0
	Magenta	-	1	1	1	1	1	1	0	0	0	0	0	0	1	1	1	1	1	1
	Yellow	-	1	1	1	1	1	1	1	1	1	1	1	1	0	0	0	0	0	0
	White	-	1	1	1	1	1	1	1	1	1	1	1	1	1	1	1	1	1	1
Red	Black	GS0	0	0	0	0	0	0	0	0	0	0	0	0	0	0	0	0	0	0
	↑	GS1	1	0	0	0	0	0	0	0	0	0	0	0	0	0	0	0	0	0
	Darker	GS2	0	1	0	0	0	0	0	0	0	0	0	0	0	0	0	0	0	0
	↑																			
	↓																			
	↓																			
	Brighter	GS61	1	0	1	1	1	1	0	0	0	0	0	0	0	0	0	0	0	0
	↓	GS62	0	1	1	1	1	1	0	0	0	0	0	0	0	0	0	0	0	0
Red	GS63	1	1	1	1	1	1	0	0	0	0	0	0	0	0	0	0	0	0	
Green	Black	GS0	0	0	0	0	0	0	0	0	0	0	0	0	0	0	0	0	0	0
	↑	GS1	0	0	0	0	0	0	1	0	0	0	0	0	0	0	0	0	0	0
	Darker	GS2	0	0	0	0	0	0	0	1	0	0	0	0	0	0	0	0	0	0
	↑																			
	↓																			
	↓																			
	Brighter	GS61	0	0	0	0	0	0	1	0	1	1	1	1	0	0	0	0	0	0
	↓	GS62	0	0	0	0	0	0	0	1	1	1	1	1	0	0	0	0	0	0
Green	GS63	0	0	0	0	0	0	1	1	1	1	1	1	0	0	0	0	0	0	
Blue	Black	GS0	0	0	0	0	0	0	0	0	0	0	0	0	0	0	0	0	0	0
	↑	GS1	0	0	0	0	0	0	0	0	0	0	0	0	1	0	0	0	0	0
	Darker	GS2	0	0	0	0	0	0	0	0	0	0	0	0	0	1	0	0	0	0
	↑																			
	↓																			
	↓																			
	Brighter	GS61	0	0	0	0	0	0	0	0	0	0	0	0	1	0	1	1	1	1
	↓	GS62	0	0	0	0	0	0	0	0	0	0	0	0	0	1	1	1	1	1
Blue	GS63	0	0	0	0	0	0	0	0	0	0	0	0	1	1	1	1	1	1	

8.5 INTERNAL PIN CONNECTION

CN1 JAE : FA5S040HF1(Suitable FPC : $t0.3\pm0.03\text{mm}$, $0.5\pm0.03\text{mm}$ pitch)

PIN No.	SIGNAL	FUNCTION
1	VDD	Power Supply for Logic
2	VDD	Power Supply for Logic
3	VDD	Power Supply for Logic
4	DCLK	Dot Clock
5	VSS	GND
6	HSYNC	Horizontal Sync Pulse
7	VSS	GND
8	DTMG	Timing Signal for Data
9	VSS	GND
10	NC	No Connection
11	VSS	GND
12	R5	Red Data
13	R4	
14	R3	
15	VSS	GND
16	R2	Red Data
17	R1	
18	R0	
19	VSS	GND
20	G5	Green Data
21	G4	
22	G3	
23	VSS	GND
24	G2	Green Data
25	G1	
26	G0	
27	VSS	GND
28	B5	Blue Data
29	B4	
30	B3	
31	VSS	GND
32	B2	Blue Data
33	B1	
34	B0	
35	PCI	Power Control In
36	VSS	GND
37	XR	Touch Panel Right Side
38	YL	Touch Panel Lower Side
39	XL	Touch Panel Left Side
40	YU	Touch Panel Upper Side

9. DIMENSIONAL OUTLINE

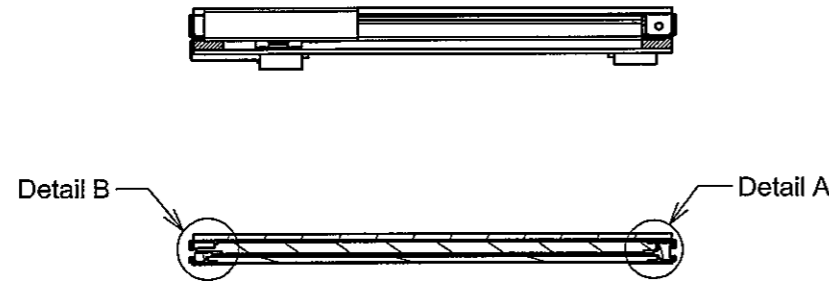
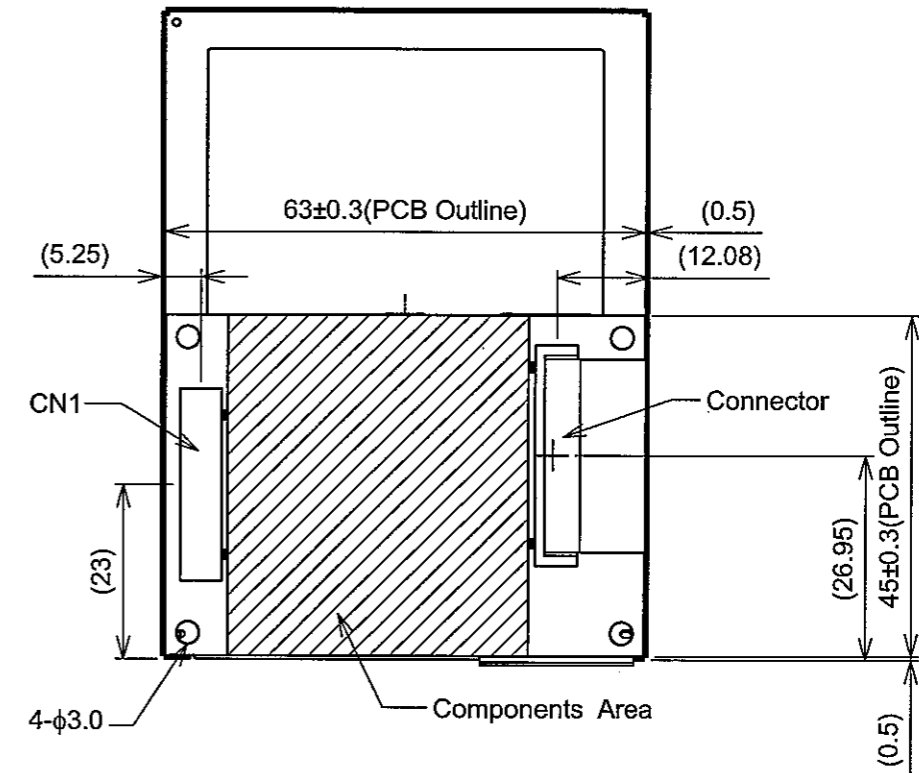
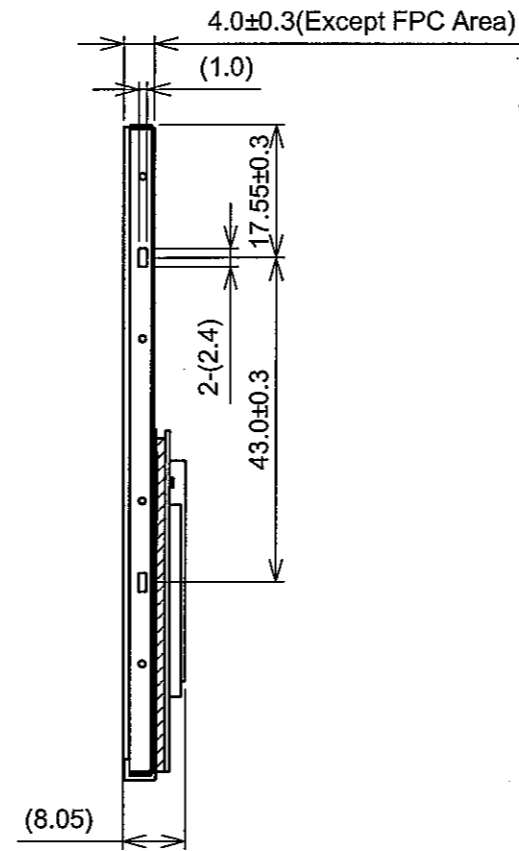
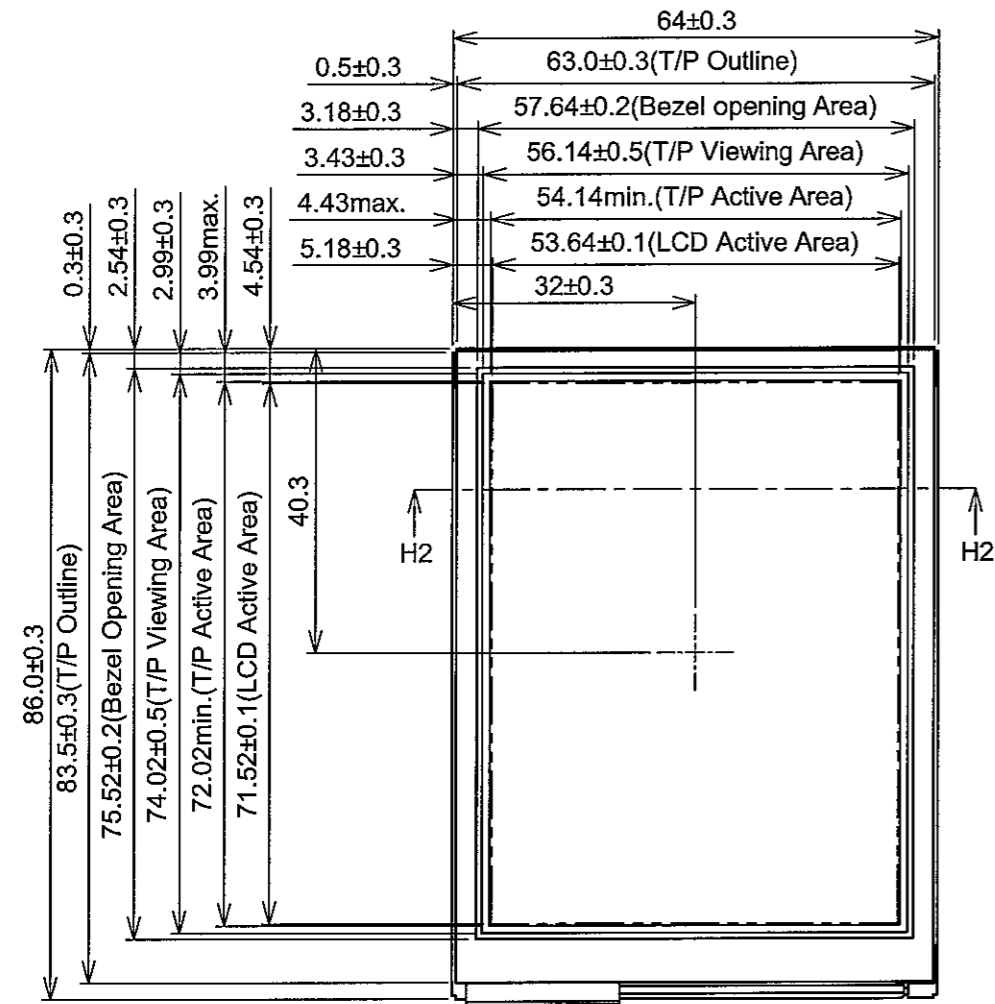

Section H2-H2

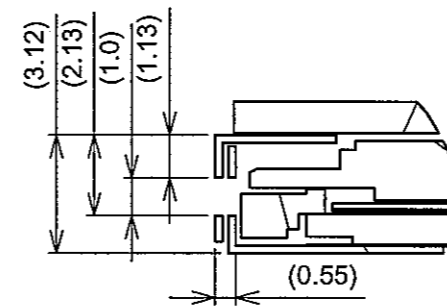

Detail B

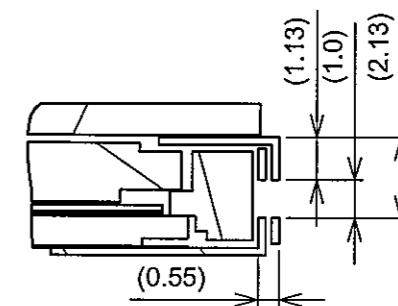

Detail A

Scale : NTS
Unit : mm

10. APPEARANCE STANDARD

10.1 APPEARANCE INSPECTION CONDITION

Visual inspection should be done under the following condition.

- (1) The inspection should be done in a dark room.(More than 1000lx and non-directive)
- (2) The distance between eyes of an inspector and the LCD module is 30cm.
- (3) The viewing zone is shown the figure.

Viewing angle $\leq 25^\circ$

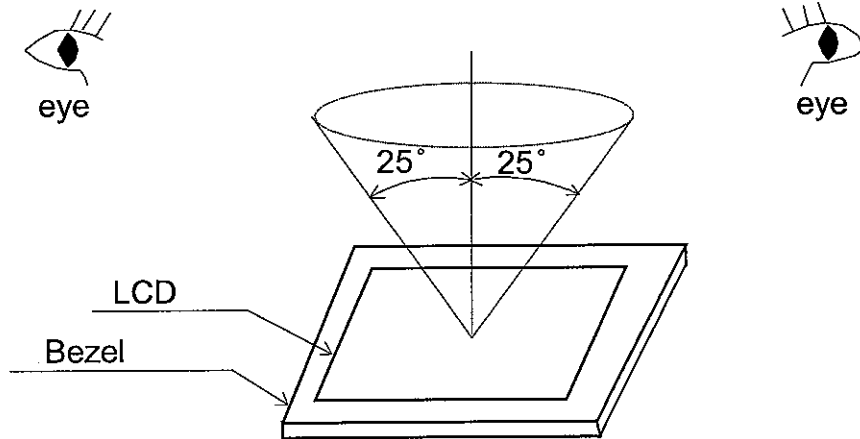

10.2 DEFINITION OF ZONE

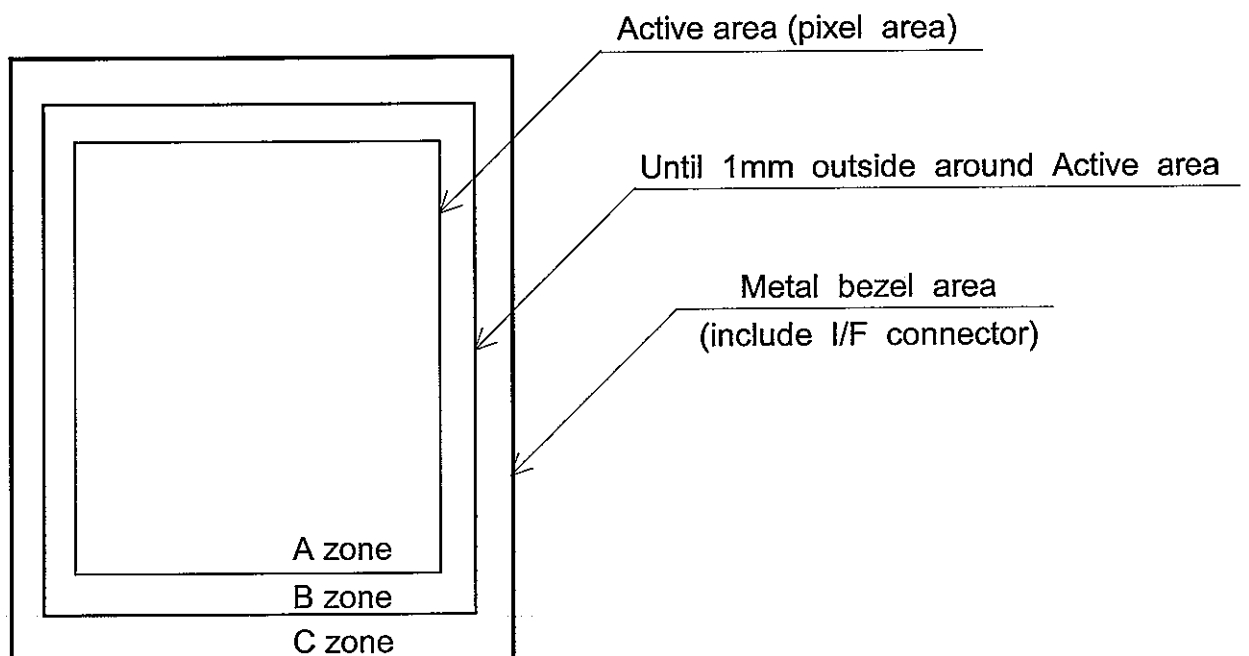

10.3 APPEARANCE SPECIFICATION

(1)LCD Appearance

*) If the problem related to this section occurs about this item, the responsible persons of both party (Customer and HITACHI) will discuss the matter in detail.

No.	ITEM	CRITERIA			APPLIED ZONE
L C D	Scratches	Length L(mm)	Width W(mm)	Maximum number acceptable	A,B
		$L \leq 2.0$	$W \leq 0.03$	ignored	
		$L \leq 2.0$	$0.03 < W \leq 0.05$	4	
		$L > 2.0$	$0.05 < W$	none	
	Dent	Distinguished one is acceptable (To be judged by HITACHI standard)			A
	Wrinkles in Polarizer	Same as above			A
	Bubbles	Average diameter D(mm)		Maximum number acceptable	A
		$D \leq 0.3$		2	
		$0.3 < D$		none	
	Stains Foreign Materials	Filamentous (Line shape)			A,B
		Length L(mm)	Width W(mm)	Maximum number acceptable	
		$L < 2.0$	$W \leq 0.05$	4	
	Dark spot	$L \leq 1.0$	$0.05 < W \leq 0.1$	2	A,B
	Round(Dot shape)				
	Average diameter D(mm)		Maximum number acceptable		
	$D \leq 0.15$		6		
	$0.15 < D \leq 0.2$		4		
	$0.2 < D$		none		
	The total number		Filamentous + Round=9		
	Those wiped out easily are acceptable				
Color Tone	To be judged by HITACHI STANDARD			A	
Color Uniformity	Same as above			A	
Dot Defect			Maximum number acceptable	A, B	
	Sparkle mode	1 dot	4		
		2 dots	2(sets)		
		Total	4		
	Black mode	1 dot	4		
		2 dots	2(sets)		
		Total	4		
	Sparkle mode & Black mode	2 dots	2(sets)		
Total		6			

(2) Touch panel appearance

Visual inspection should be done under the following condition.

- * The inspection should be done in a dark room. (more than 500 lx) and non-directive)
- * The distance between eyes of an inspector and the LCD module is 30 cm.
- * The viewing angle $\leq 60^\circ$.

No.	ITEM	CRITERIA			APPLIED ZONE
		Length L(mm)	Width W(mm)	Maximum number acceptable	
TOUCH PANEL	Scratches	-	$W < 0.05$	ignored	A,B
		$10 < L$	$0.05 \leq W < 0.1$	none	
		-	$0.1 \leq W$	none	
		Filamentous (Line shape)			
	Foreign Materials	Length L(mm)	Width W(mm)	Maximum number acceptable	A,B
		-	$W < 0.05$	Ignored	
		$L > 3$	$0.05 \leq W \leq 0.1$	none	
		-	$W \geq 0.1$	Round	
	Dark Spot	Round(Dot shape)			A,B
		Average diameter D(mm)		Maximum number acceptable	
		$D \leq 0.25$		ignored	
		$0.25 < D \leq 0.35$		6	
		$0.35 < D$		none	
	Newton Ring (Touch Panel)	To be judged by HITACHI standard			A,B
	Touch Panel Uncleaness	No conspicuous dirt			A
	Rubbing Scratch	To be judged by HITACHI standard			-

(3) Glass indentation

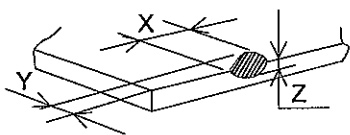
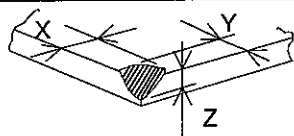
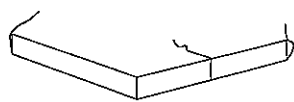
ITEM	SPECIFICATIONS						
Common Indentation	 <table border="1" style="display: inline-table; vertical-align: middle;"> <tr> <td>X</td> <td>Y</td> <td>Z</td> </tr> <tr> <td>≤ 5.0</td> <td>≤ 3.0</td> <td>$\leq t$</td> </tr> </table>	X	Y	Z	≤ 5.0	≤ 3.0	$\leq t$
X	Y	Z					
≤ 5.0	≤ 3.0	$\leq t$					
Corner Broken	 <table border="1" style="display: inline-table; vertical-align: middle;"> <tr> <td>X</td> <td>Y</td> <td>Z</td> </tr> <tr> <td>≤ 3.0</td> <td>≤ 3.0</td> <td>$\leq t$</td> </tr> </table>	X	Y	Z	≤ 3.0	≤ 3.0	$\leq t$
X	Y	Z					
≤ 3.0	≤ 3.0	$\leq t$					
Proceeding Crack	 <p style="text-align: center;">None</p>						

Note 1 : Definition of average diameter (D)

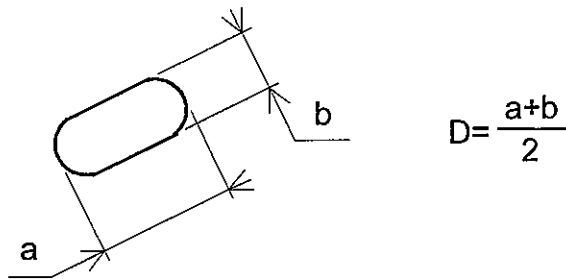

Note 2 : Definition of length (L) and width (W)

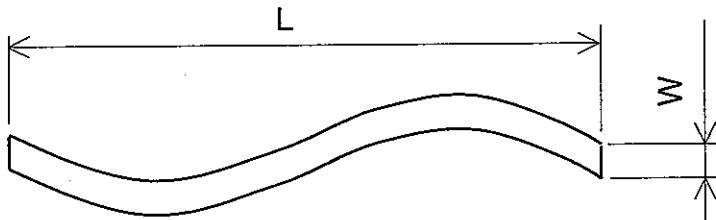

Note 3 : Definition of dot defect

- (a) Dot Defect : Defect Area > 1/2 dot
- (b) Sparkle mode : Brightness of dot is more than 30% at Black raster.
- (c) Black mode : Brightness of dot is less than 70% at R.G.B raster.
- (d) 1 dot : Defect dot is isolated , not attached to other defect dot.
- (e) N dot : N defect dots are consecutive (fig.1).
(N means the number of defect dots.)

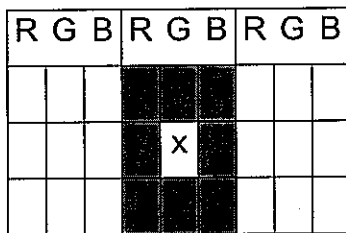

2 dots defect included defect dot "X" is defined as follows.

Adjacent dots to defect dot "X" :

- (f) Counting definition of adjacent dots(1 sets) : same as 1 dot defect.
- (g) Those wiped out easily are acceptable

11. PRECAUTION IN DESIGN

11.1 MOUNTING PRECAUTION

(1) When assembling the Touch Panel and you case, please refer to the figure below.

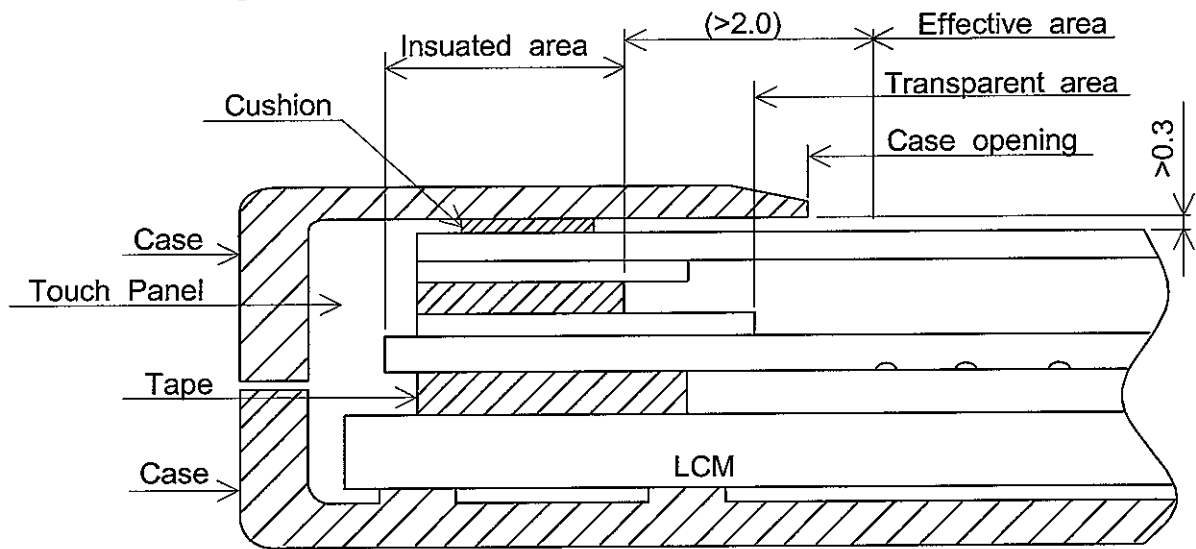

- (2) The clearance between the Touch Panel and case shall be designed so that the case edge never presses the input screen when it is deformed by heat or other causes.
- (3) The case shall be designed not to touch the tail portion (FPC for Touch Panel).
- (4) The boundary space between the effective area and the insulated area is unstable. Touching this area may effect the operation of the Touch Panel. The case must be designed so that it does not touch the boundary space.

11.2 PRECAUTIONS AGAINST ELECTROSTATIC DISCHARGE

As this module contains C-MOS LSIs, it is not strong against electrostatic discharge. Make certain that the operator's body is connected to the ground through a list band, etc.

And don't touch I/F pins directly.

11.3 HANDLING PRECAUTIONS

- (1) Since the Touch Panel on the top, and the frame on the bottom tend to be easily damaged, they should be with full care so as not to get them touched, pushed or rubbed by a piece on glass, tweezers and anything else which are harder a pencil lead 3H.

- (2) As the adhesives used for adhering upper/lower polarizer's and frame are made of organic substances which will be deteriorated by a chemical reaction with such chemicals as acetone, toluene, ethanol and isopropyl alcohol. The following are recommended for use :
normal hexane

Please contact with us when it is necessary for you to use chemicals other than the above.

- (3) Lightly wipe to clean the dirty surface with absorbent cotton or other soft material like chamois, soaked in the recommended chemicals without scrubbing it hardly.
Always wipe the surface horizontally or vertically. Never give a wipe in a circle. To prevent the display surface from damage and keep the appearance in good state, it is sufficient, in general, to wipe it with absorbent cotton.
- (4) Immediately wipe off saliva or water drop attached on the display area because it may cause deformation or faded color.
- (5) Foggy dew deposited on the surface may cause a damage, stain or dirt to the polarizer.
When you need to take out the LCD module from some place at low temperature for test, etc.
It is required to be warmed them up to temperature higher than room temperature before taking them out.
- (6) Touching the display area or I/F pins with bare hands or contaminating them are prohibited, because the stain on the display area and poor insulation between terminals are often caused by being touched with bare hands.
(Some cosmetics are detrimental to polarizer's.)
- (7) In general, the glass is fragile so that, especially on its periphery, tends to be cracked or chipped in handling. Please not give the LCD module sharp shocks by falling , etc.
- (8) Maximum pressure to the surface must be less than 1.96×10^4 Pa.
And if the pressure area is less than 1cm^2 , maximum pressure must be less than 1.96N.
- (9) Since the metal width is narrow on these locations (see page 9-1/1), please careful with handling.
- (10) Top sheets shall be cleaned gently using a soft cloth such as those used for glasses.
Hard wiping accumulated dust will leave scars on the surface even using a cloth.

11.4 OPERATION PRECAUTION

- (1) Using a LCM module beyond its maximum ratings may result in its permanent destruction.
LCM module's should usually be used under recommended operating conditions shown in chapter 4. Exceeding any of these conditions may adversely affect its reliability.

- (2) Response time will be extremely delayed at lower temperature than the specified operating temperature range and on the other hand LCD's shows dark blue at higher temperature.
However those phenomena do not main defects of the LCD module. Those phenomena will disappear in the specified operating temperature range.
- (3) If the display area is pushed hard during operation, some display patterns will be abnormally display.
- (4) A slight dew depositing on terminals may cause electrochemical reaction which leads to terminal open circuit. Please operate the LCD module under the relative condition of 40°C 85%RH.
- (5) Resistance range : Your controller shall be set up to allow the resistance range of Touch Panel specified in our CAS.
- (6) Pointed position of Touch Panel may shift owing to a change in resistance of Touch Panel depending on the operation condition . To compensate this shift, the set shall be given a calibration function.
- (7) Input shall be made with a stylus pen (polyacetal , R0.8). Chances are very high that use of a metal piece including a ball point pen or sharp edge will impair accuracy.
- (8) The Touch Panel is an auxiliary input device. The system shall be designed to have other input device.

11.5 STORAGE

In case of storing LCD module for a long period of time (for instance, for years) for the purpose of replacement use, the following precautions necessary.

- (1) Store the LCD modules in a dark place; do not expose them to sunlight or ultraviolet rays.
- (2) Keep the temperature between -20°C and 60°C at normal humidity.
- (3) Store the LCD modules in the container which is used for shipping from us.
- (4) No articles shall be left on the surface over an extended period of time.

11.6 SAFETY

Wear finger cots or gloves whenever handling or assembling a Touch Panel its glass edges are sharp.

12. DESIGNATION OF LOT MARK

12.1 LOT MARK

Lot mark is consisted of 4 light for production lot 6 or 7 digits for production control..



Year	Mark
2004	4
2005	5
2006	6
2007	7
2008	8

Month	Jan.	Feb.	Mar.	Apr.	May	Jun.
Mark	01	02	03	04	05	06
Month	Jul.	Aug.	Sep.	Oct.	Nov.	Dec.
Mark	07	08	09	10	11	12

Week (Day In Calendar)	Figure In Lot Mark
01~07	1
08~14	2
15~21	3
22~28	4
29~31	5

12.2 Location of Label : On the FPC

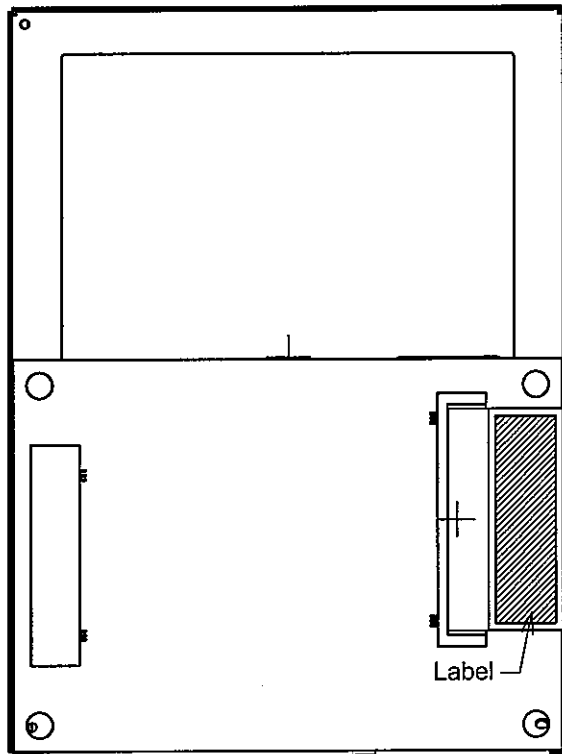

HITACHI
TX09D50VM1CCA
MADE IN TAIWAN

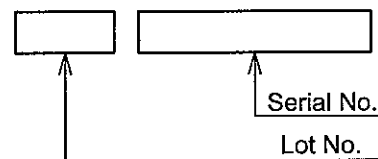

13. PRECAUTION FOR USE

(1) A limit sample should be provided by the both parties on an occasion when the both parties agree to its necessity.

Judgement by a limit sample shall take effect after the limit sample has been established and confirmed by the both parties.

(2) On the following occasions, the handling of the problem should be decided through discussion and agreement between responsible persons of the both parties.

1) When a question is arisen in the specifications.

2) When a new problem is arisen which is not specified in this specifications.

3) When an inspection specifications change or operating condition change by customer is reported to HITACHI, and some problem is arisen in the specification due to the change.

4) When a new problem is arisen at the customer's operating set for sample evaluation.

(3) Regarding the treatment for maintenance and repairing, both parties will discuss it in six months later after latest delivery of this product.

The precaution that should be observed when handling LCM have been explained above.

If any points are unclear or if you have any requests , please contact with HITACHI.