

General Description

The RSC-4128 represents Sensory's next generation speech and analog I/O mixed signal processor. The RSC-4128 is designed to bring advanced speech I/O features to cost sensitive embedded and consumer products. Based on an 8-bit microcontroller, the RSC-4128 integrates speech-optimized digital and analog processing blocks into a single chip solution capable of accurate speech recognition; high quality, low data-rate compressed speech; and advanced music. Products can use one or all features in a single application.

The RSC-4128 supports Sensory Speech™ 7 technology, which includes advanced speech algorithms that add features and improve performance. Capable of running both new HMM and enhanced neural network technologies, accuracy in all kinds of noise is dramatically improved. New Speaker Verification technology is perfect for voice password security applications that must work in noisy environments. New high quality compressed speech technology reduces data rates by 5 times. New 8 voice MIDI-compatible music includes drum tracks, effectively increasing instruments beyond 8. Simultaneous music and speech rounds out the Sensory Speech™ 7 technology.

The RSC-4128 also supports the revolutionary capability of creating speaker independent recognition sets by simply typing in the desired recognition vocabulary! A few keystrokes creates a recognition set in seconds without the wait or cost of recording sessions to train the recognizer, speeding time to sales.

A new and unique Audio Wakeup feature listens while the RSC-4128 is in power down mode. When an audio event such as a clap or whistle occurs, Audio Wakeup will wakeup the RSC-4128 for speech or application tasks. Audio Wakeup is perfect for battery applications that require continuous listening and long battery life.

In addition to improved recognition performance, the RSC-4128 provides further on-chip integration of features. A complete speech I/O application can be built with as few additional parts as a clock crystal, speaker, microphone, and few resistors and capacitors.

Moreover, the RSC-4128 provides an unprecedented level of cost effective system-on-chip (SOC) integration, enabling many applications that require DSP and/or audio processing. The RSC-4128 may be used as a general-purpose mixed signal processor platform for custom algorithms, technologies and applications.

Features

Full Range of Sensory Speech™ 7 Capabilities

- ▶ Enhanced Word Spotting capability (10 SI or 4 SD words) in parallel
- ▶ Noise robust Speaker Independent, Dependent & Continuous Listening recognition
- ▶ Speaker Verification (SVWS) – Noise robust voice biometric security
- ▶ High quality, 3.7-7.8 kbps speech synthesis & sound effects with Sensory “SX” synthesis technology
- ▶ 8 voice MIDI-compatible music synthesis coincident with speech; drum track feature enables additional voices
- ▶ Voice record & playback
- ▶ Audio Wakeup from sleep

Integrated Single-Chip Solution

- ▶ 8-bit microcontroller
- ▶ ROMless, 128KByte and 256KByte ROM options
- ▶ 16 bit ADC, 10 bit DAC and microphone pre-amplifier
- ▶ Independent, programmable Digital Filter engine
- ▶ 4.8 KBytes total RAM (256Bytes “user” application RAM)
- ▶ Five timers (3 GP, 1 Watchdog, 1 Multi Tasking)
- ▶ Twin-DMA, Vector Math accelerator, and Multiplier
- ▶ Built-in Analog Comparator Unit (4 inputs)
- ▶ External memory bus: 20-bit Address(1Mbyte), 8-bit Data
- ▶ On chip storage for SD, SV, templates (10 templates)
- ▶ Code security through no ROM dump capability
- ▶ Uses low cost 3.58MHz crystal (internal PLL)
- ▶ Low EMI design for FCC and CE requirements
- ▶ 24 configurable I/O lines with 10 mA (typical) outputs
- ▶ Fully nested interrupt structure with up to 8 sources
- ▶ Optional Real Time Clock

Long Battery Life

- ▶ 2.4 – 3.6V operation
- ▶ 12mA (typical) operating current at 3V
- ▶ 2 low power modes; 1 μ A typical sleep current

Full Suite of Quick & Powerful Tools

- ▶ Quick Text-to-SI (T2SI) text entry to build noise robust SI recognition sets – low cost & push-button – no recording!
- ▶ Quick Synthesis for push-button speech compression
- ▶ Integrated Development Environment, C Compiler, Debugger & In Circuit Emulator from Phytion, Inc.

Table of Contents

General Description	1
RSC-4128 Overview	4
Speech Technologies	5
<i>Speech Recognition</i>	5
<i>Speaker Verification</i>	5
<i>Speech and Music Synthesis</i>	5
<i>Record and Playback</i>	5
RSC-4128 Architecture	6
Reference Schematic	8
Using the RSC-4128	9
<i>Instruction Set</i>	9
<i>Stack</i>	10
<i>Register RAM</i>	10
<i>L1 Vector Accelerator/Multiplier</i>	11
<i>Power and Wakeup Control</i>	11
<i>General Purpose I/O</i>	12
<i>Memory Addressing</i>	14
<i>Wait States</i>	16
<i>On-Chip ROM</i>	18
<i>Oscillators</i>	18
<i>Clocks</i>	18
<i>Timers/Counters</i>	19
<i>Interrupts</i>	22
<i>Analog input</i>	24
<i>Audio Wakeup</i>	25
<i>Microphones</i>	26
<i>Reset</i>	27
<i>Digital-to-Analog-Converter (DAC) Output</i>	27
<i>Pulse Width Modulator (PWM) Analog Output</i>	29
<i>Comparator Unit</i>	31
Instruction Set Opcodes and Timing Details	33
<i>MOVE Group Instructions</i>	33
<i>ROTATE Group Instructions</i>	34
<i>BRANCH Group Instructions</i>	35
<i>ARITHMETIC/LOGICAL Group Instructions</i>	35
<i>MISCELLANEOUS Group Instructions</i>	36
Special Functions Registers (SFRs) Summary	37
DC Characteristics	39
A.C. Characteristics (External memory accesses)	39
Timing Diagrams	40
Absolute Maximum Ratings	40
Package Options	41

Die Pad Ring	44
RSC-4128 Die Bonding Pad Locations.....	45
Mechanical Data.....	46
Ordering Information.....	48
The Interactive Speech™ Product Line	49

RSC-4128 Overview

The RSC-4128 is a member of the Interactive Speech™ line of products from Sensory. It features a high-performance 8-bit microcontroller with on-chip ADC, DAC, preamplifier, RAM, ROM (except on ROM-less version), and optimized audio processing blocks. The RSC-4128 is designed to bring a high degree of integration and versatility into low-cost, power-sensitive applications. Various functional units have been integrated onto the CPU core in order to reduce total system cost and increase system reliability.

The RSC-4128 operates in tandem with Sensory Speech™ 7 firmware, an ultra compact suite of recognition and synthesis technologies. This reduced software footprint enables, for example, products with over 150 seconds of compressed speech, multiple speaker dependent and independent vocabularies, speaker verification, and all application code built into the RSC-4128 as a single chip solution. Revolutionary Text-to-Speaker-Independent (T2SI) technology allows the creation of SI recognition sets by simply entering text.

The CPU core embedded in the RSC-4128 is an 8-bit, variable-length-instruction microcontroller. The instruction set is similar to the 8051 microcontroller, and has a variety of addressing mode, *MOV* and 16 bit instructions. The RSC-4128 processor avoids the limitations of dedicated A, B, and DPTR registers by having completely symmetrical sources and destinations for all instructions.

The RSC-4128 provides a high level of on-chip features and special DSP engines, providing a very cost effective mixed signal platform for general-purpose applications and development of custom algorithms. The full suite of industry standard tools for easy product development makes the RSC-4128 an ideal platform for consumer electronics.

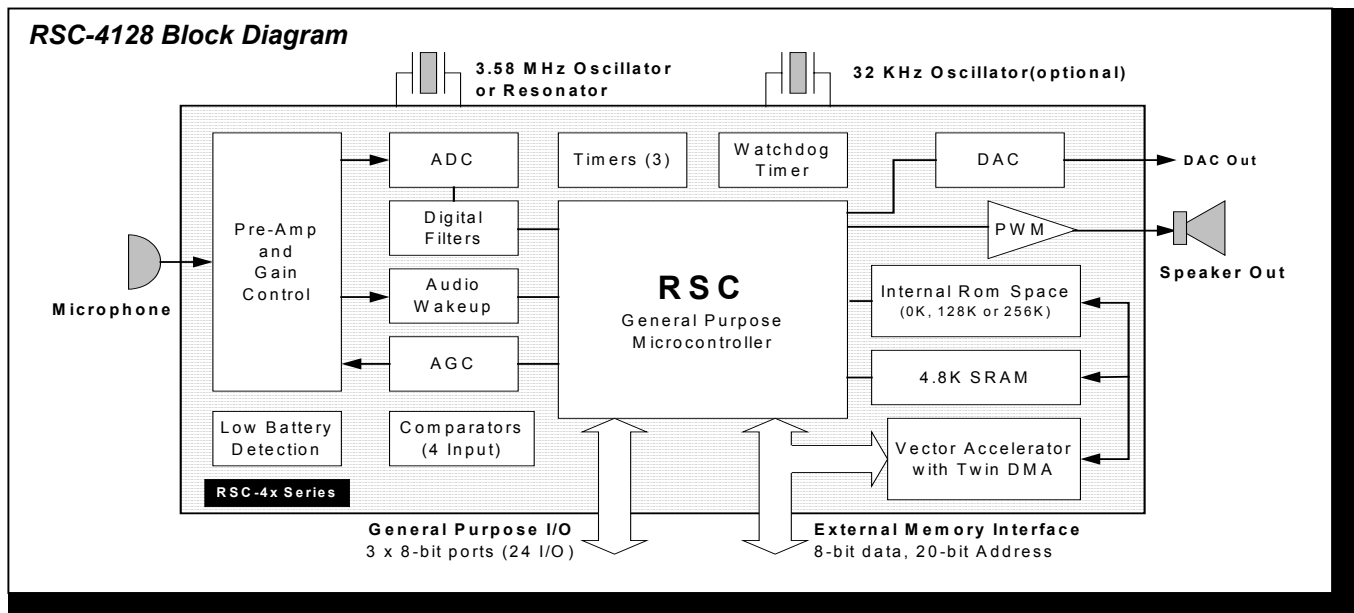

Speech Technologies

Speech Recognition

The RSC-4128 is designed to support HMM (Hidden Markov Modeling) as well as Neural Network technologies provided in Sensory Speech™ 7 firmware, to perform speaker independent (SI) speech recognition. Speaker independent recognition requires on-chip or off-chip ROM to store the words to be recognized.

Speaker dependent (SD) recognition requires programmable memory to store personalized speech templates. This programmable memory may be on-chip SRAM or off-chip Serial EEPROM, Flash Memory, or SRAM.

The RSC-4128 has several additional speech recognition features as described below:

- ▶ *Speaker Independent* recognition requires no user training. The RSC-4128 can recognize up to 20 words in an active set (number of sets is limited only by internal ROM or external memory size). Text-to-SI (T2SI) recognition, based on HMM technology, allows creation of SI recognition sets in seconds by simply typing in the vocabulary desired, with no costs or delays associated with recording and training the recognizer.
- ▶ *Speaker Dependent* recognition allows the user to create names for products or customize vocabularies. Up to 100 words can be recognized in an active set (number of sets is limited only by internal ROM or external memory size). The RSC-4128 can store up to 10 SD words in on-chip SRAM.
- ▶ *Continuous Listening* allows the chip to continuously listen for a specific trigger word. With this feature, a product “activates” when a specific word is spoken, framed by quiet before and after. Continuous listening provides the lowest false fire rate for trigger words.
- ▶ *Word Spotting* allows the chip to continuously recognize for up to 10 SI or 5 SD words at a time. In word spotting mode, the word(s) to be recognized may be spoken in the middle of speech.

Speaker Verification

The RSC-4128 also supports Sensory’s speaker verification (SV) technology – the most successful biometric security on the market. After a speaker trains the chip on a specific word or words, the chip is able to identify whether a particular word is spoken by the original speaker. The RSC-4128 can store up to 10 SV templates on-chip, or more with external programmable memory.

Speech and Music Synthesis

The RSC-4128 provides high-quality speech synthesis using state-of-the-art frequency domain techniques in Sensory’s new “SX” synthesis technology. Typical data rates for SX are approximately 6000 bits per second. One may select various data rates from approximately 3.7 to 7.8Kbps to manage speech quality versus allotted memory.

Speech, music and sound effects may also be produced using the RSC-4128 8 bit, 58Kbps or 4 bit, 30Kbps compression technologies.

The RSC-4128 provides high-quality, eight-voice, wave table music synthesis which allows multiple, simultaneous instruments for harmonizing. The RSC-4128 uses a MIDI-like system to generate music. One or more of the eight voices may be speech playback instead of music. One or more of the eight voices may be a drum track comprising multiple drums. In effect, this allows the number of simultaneous instruments to exceed 8.

Speech and music synthesis requires on-chip or off-chip ROM to store data for synthesis playback. Easy to use tools allow the developer to record and compress their own voice talents and create with the push of a button, or to create their own MIDI scores and instruments.

Record and Playback

The RSC-4128 can perform speech record and playback (sometimes called “voice memo”) at various compression levels depending on the quantity and quality of playback desired. Data rates less than 14,000 bits per second are achievable while maintaining very high quality reproduction. The record and playback technology also performs silence removal to improve sound quality and reduce memory requirements.

RSC-4128 Architecture

The RSC-4128 is a highly integrated speech and analog I/O mixed signal processor that combines:

- ▶ 8-bit microcontroller with enhanced instructions and interrupt control, superior register architecture, independent Digital Filter engine and “L1” Vector Math Accelerator
- ▶ On-chip ROM and RAM (4.8 Kbytes), and the ability to address off-chip RAM, ROM, EPROM or Flash.
- ▶ Input microphone preamp and 16 bit Analog-to-Digital Converter (ADC) for speech and audio/analog input
- ▶ 10 bit Digital-to-Analog Converter (DAC), and 10 bit Pulse Width Modulator (PWM) to directly drive a speaker or other analog device
- ▶ Low power Audio Wakeup from power down mode, when a selected audio event, such as clap or whistle, occurs

The RSC-4128 has 20-bit address and 8-bit data busses for interfacing with external memory. It includes an -XM input pin capable of enabling or disabling the internal ROM.

NOTE: Neither the -XM input pin nor the extended memory busses are available on 64-lead LQFP packaged versions of the RSC-4128 with internal ROM. These are available on the die and 100 LQFP versions.

Three bi-directional ports provide 24 configurable, general-purpose I/O pins to communicate with or control external devices with a variety of source and sink currents. Up to 4 of these I/O may be used as programmable Analog Comparator inputs. 16 may be used as I/O wakeup.

The RSC-4128 has a high frequency (14.32 MHz) clock as well as a low frequency (32,768 Hz) clock. The processor clock can be selected from either source, with a selectable divider value. The device performs speech recognition when running at 14.32 MHz. The RSC-4128 also supports programmable wait states to allow the use of slower memory.

OSC1 is a very low-cost 3.58 MHz crystal oscillator which is used by a 4X PLL to generate the 14.32MHz clock. The OSC2 oscillator provides the options of using an external crystal or its own internal RC devices (no external components required for the internal RC mode).

There are three programmable, general-purpose 8-bit counters / timers – Timers 1 and 3 are derived from OSC1, and Timer2 from OSC2. There is also a Watchdog timer that may be used to exit an undesired condition in program flow, and Multi-tasking timer to allow chip operations to share resources in parallel.

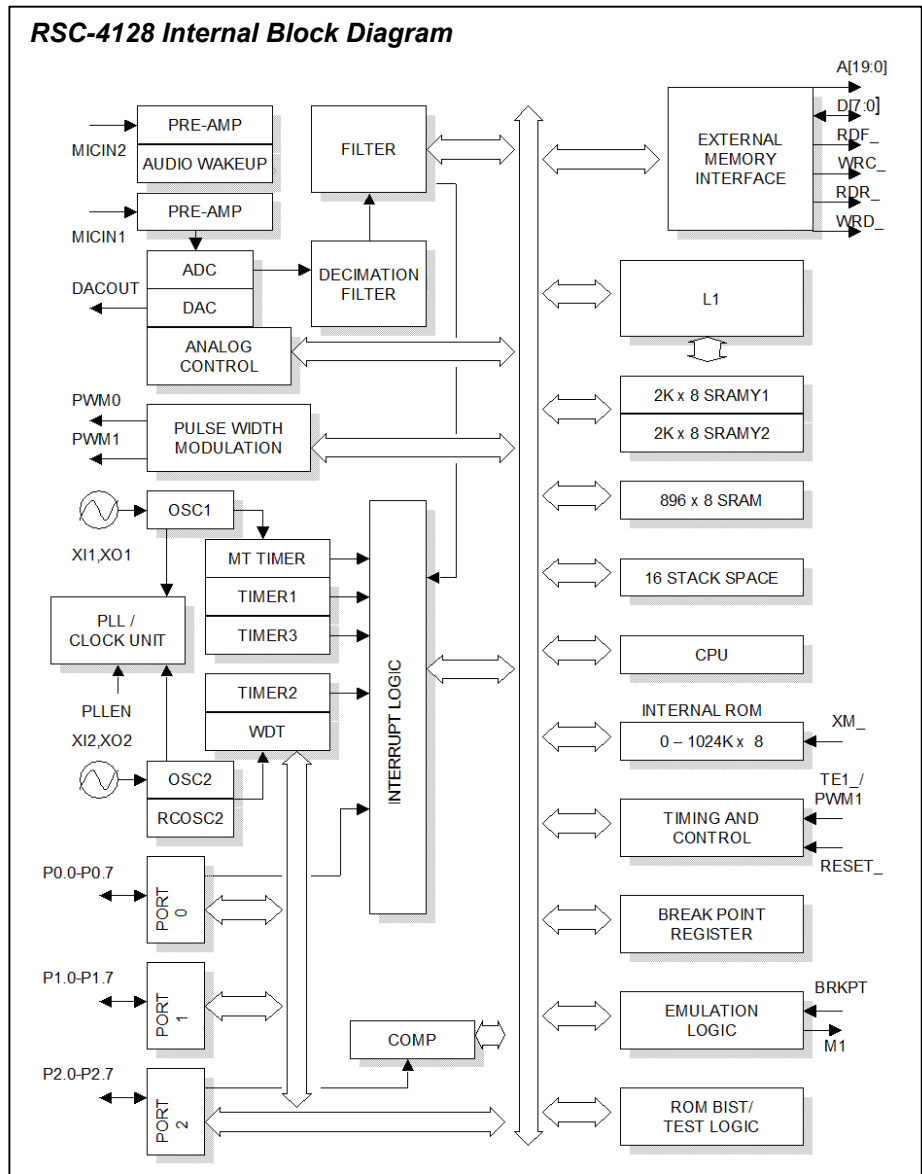

A single chip speech I/O solution may be created with the RSC-4128. An external microphone passes an audio signal to the preamplifier and ADC to convert the incoming speech signal into digital data. Speech features are extracted using the Digital Filter engine. The microcontroller CPU processes these speech features using speech recognition algorithms in firmware, with the help of the "L1" Vector Accelerator and enhanced instruction set. The resulting speech recognition results may be used to control the consumer product application code, or to output speech or audio in the form of a dialog with the user of the consumer product. If desired, the output speech or audio signal from the RSC-4128 is generated by a DAC for external amplification into a speaker, or a PWM capable of directly driving a speaker at typical consumer product volumes. A typical product will require about \$0.30 - \$1.00 (in high volume) of additional components, in addition to the RSC-4128.

The RSC-4128 also provides a very cost effective mixed signal platform for general-purpose applications and development of custom algorithms. A typical general purpose application will require about \$0.30 - \$0.50 (in high volume) of additional components, in addition to the RSC-4128.

Reference Schematic

Schematic 1-1

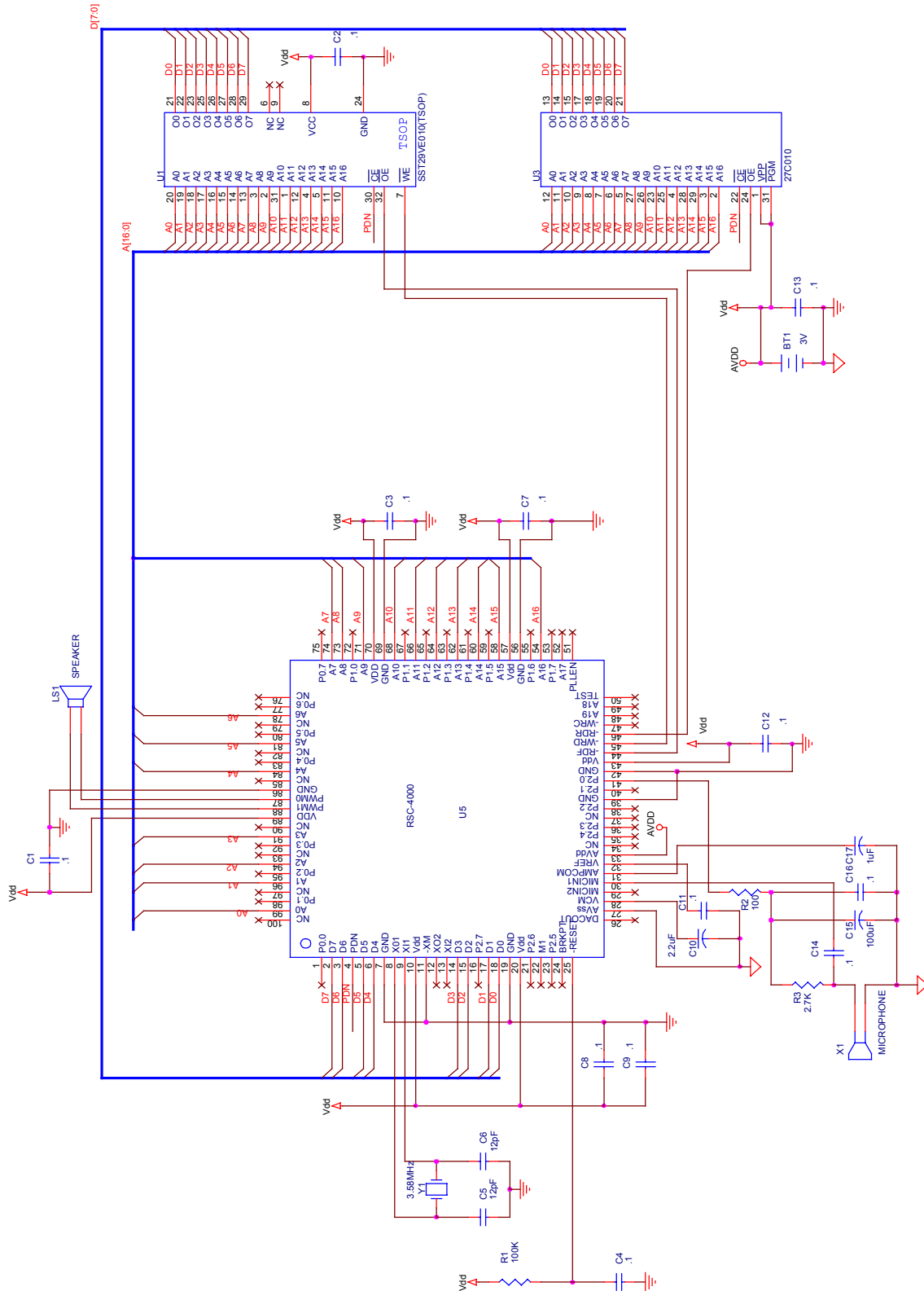

Using the RSC-4128

Creating applications using the RSC-4128 requires the development of electronic circuitry, software code, and speech/music data files. Software code for the RSC-4128 can be developed using a complete suite of RSC-4128 development tools including In-Circuit Emulator, C Compiler, and “push button” tools for speech recognition and synthesis data files. Sensory provides free design reviews of customer applications to assist in the speech dialog and speech I/O design. Sensory also offers application development services. For more information about development tools and services, please contact Sensory.

When using the RSC-4128 macro blocks such as the AFE, digital filters, L1, etc, for purposes other than as intended in the Sensory Speech 7 technology modules, in applications that will also use Sensory Speech 7, care must be taken to avoid conflicts that may cause adverse impact on functionality. Contact Sensory Technical Support for help in avoiding these conflicts.

Instruction Set

The instruction set for the RSC-4128 has 60 instructions comprising 13 move, 7 rotate, 11 branch, 22 arithmetic, and 7 miscellaneous instructions. All instructions are 3 bytes or fewer and no instruction requires more than 10 clock cycles (plus wait states) to execute. (see “Instruction Set Opcodes and Timing Details” for detailed descriptions)

Flags

The “flags” register (register FF) has bits that are set/cleared by arithmetic/logical instructions, a trap enable bit set under program control, a read-only stack overflow bit cleared at power on and set by stack wrap around, and the Global Interrupt Enable bit:

0FFH	R/W	“flags”	
	Bit 7:	carry	
	Bit 6:	zero	(set = 1 when result of arith/log instruction is 0)
	Bit 5:	sign	(set = 1 when result of arith/log instruction has msb high)
	Bit 4:	trap	
	Bit 3:	stkoflo	(read-only, initialized to 0, set to 1 on stack overflow)
	Bit 3:	stkfull	(read-only, initialized to 0, set to 1 on stack full)
	Bit 1:	(unused)	
	Bit 0:	gie	(Global Interrupt Enable)

NOTE: The “trap” bit must be left written as “0”.

Flags Hold

The “flagsHold” register (register CF) stores the “flags” value when an interrupt occurs. Unlike previous RSC chips, the RSC-4128 processor has read/write access to “flagsHold” for multi-tasking purposes. Since the “flags” register is restored from the “flagsHold” register upon return from interrupt, the “stkoflo” and “stkfull” bits are omitted from the “flagsHold” register to prevent inadvertent clearing of these bits.

0CFH	R/W	“flagsHold”	
	Bit 7:	carry	
	Bit 6:	zero	
	Bit 5:	sign	
	Bit 4:	trap	
	Bit 3:	(unused – reads 0)	
	Bit 2:	(unused – reads 0)	
	Bit 1:	(unused – reads 0)	
	Bit 0:	gie	

NOTE: The “trap” bit must be left written as “0”.

See the discussion in “Interrupts” section relating to the value of “gie” stored in the “flagsHold” register when an interrupt occurs during execution of an instruction that clears the “gie” bit.

Stack

There is a 16-level, 16-bit stack for saving the program counter for subroutine calls and interrupt requests. The stack pointer wraps around on overflow or underflow. When the stack read and write pointers indicate that stack overflow has occurred, the “stkoflo” bit in the “flags” register is set. Once set, this bit can only be cleared by a processor reset. The bit may be tested by software, but it performs no other function. When the stack read and write pointers indicate that stack is full, the “stkfull” bit in the “flags” register is set. This bit will be reset once the stack is not full.

Stack Pointers

The 16-level stack has two 4-bit pointers, stack write and stack read. They are normally written by the processor upon execution of a “CALL” instruction or an interrupt.

The stack also has a 6-bit index register “stkNdx” (register F6) and an 8-bit data port register “stkData” (register F7) that are used to access the stack contents as bytes in a register file under program control. The contents of the stack location selected by the “stkNdx” register may be read or written by the processor via *MOV* instructions at the “stkData” register. The stack register index must be written first, then the stack data can be read.

The Stack read and write pointers (4 bits each) are also mapped to addresses accessible via the Stack Register Index.

Stack contents accessed by value in stack register index (“stkNdx”, register F6)

00H	Stack0 Lo	08H	Stack4 Lo	10H	Stack8 Lo	18H	StackC Lo
01H	Stack0 Hi	09H	Stack4 Hi	11H	Stack8 Hi	19H	StackC Hi
02H	Stack1 Lo	0AH	Stack5 Lo	12H	Stack9 Lo	1AH	StackD Lo
03H	Stack1 Hi	0BH	Stack5 Hi	13H	Stack9 Hi	1BH	StackD Hi
04H	Stack2 Lo	0CH	Stack6 Lo	14H	StackA Lo	1CH	StackE Lo
05H	Stack2 Hi	0DH	Stack6 Hi	15H	StackA Hi	1DH	StackE Hi
06H	Stack3 Lo	0EH	Stack7 Lo	16H	StackB Lo	1EH	StackF Lo
07H	Stack3 Hi	0FH	Stack7 Hi	17H	StackB Hi	1FH	StackF Hi
20-2FH	(unused)	30-3DH	(unused)	3EH	StackWritePtr (4bits only)	3FH	StackReadPtr (4bits only)

Register RAM

The RSC-4128 has a total physical register RAM space of 896 bytes, divided into 14 banks of 64 bytes each. There is an additional 64 bytes of Special Function Registers (SFRs). Two of the register RAM banks are directly addressed as unbanked memory, and the other 12 banks are banked.

Addressing 896 bytes requires an address width of 10 bits. (architecturally, an 11 bit address is implemented to allow for future increases in the register RAM). Logical register space addresses are 8 bits only (256 bytes), so 5 bank select bits in the “bank” register (register FC) are used so to access the full 896 bytes. The 256 byte logical register space map is divided into 4 different 64 byte sections:

000H-03FH	unbanked register RAM
040H-07FH	unbanked register RAM
080H-0BFH	banked register RAM
0C0H-0FFH	SFRs

Bits [4:0] of the “bank” register determine which physical bank of 64 bytes is logically mapped to addresses 080H-0BFH. When an address falls in the logically mapped range of 080H-0BFH, the lower 6 bits of the address (64 byte address) are used directly and the bank select bits are used as the upper 5 bits of the 11-bit physical register RAM address. When the address falls below the logically mapped range of 080H-0BFH, the lower 8 bits of the address are used directly to address the unbanked register RAM. When the address falls in the logically mapped range for the SFRs (0C0H-0FFH) the SFRs are addressed, not the register RAM.

Mapping of logical addresses 080H-0BFH (“bank” register FC is used)

register FC [4:0]	Physical RAM memory	register FC [4:0]	Physical memory
00H	00-3FH	08H	200-23FH
01H	40-7FH	09H	240-27FH
02H	80-BFH	0AH	280-2BFH
03H	C0-FFH	0BH	2C0-2FFH
04H	100-13FH	0CH	--- (unimplemented)
05H	140-17FH	0DH	--- (unimplemented)
06H	180-1BFH	0EH	--- (unimplemented)
07H	1C0-1FFH	0FH	--- (unimplemented)

NOTE: If a value other than those indicated above is used for the “bank” register, an undefined state will result.

See the “Special Functions Registers Summary” for details on the contents of SFRs.

L1 Vector Accelerator/Multiplier

A variety of macros are provided by Sensory that manipulate the L1 Vector Accelerator to provide signed and unsigned multiplication functions. See the “Sensory Speech 7 Technology Library Manual” for information on these macros and their application.

The L1/Multiplier unit may be independently powered down by programming the register D6.Bit 4 to “0” (“clkExt” register, “L1clk_on” bit).

Digital Filter

The RSC-4128 has a Digital Filter engine capable of dividing up a frequency range into several smaller ranges. It is also capable of reporting characteristics of each range to the RSC-4128 processor. The configuration of the Digital Filter engine and access to signal characteristics generated are enabled by technology modules which are available from Sensory “Technology Support” upon request.

Power and Wakeup Control

The typical Active Supply Current is realized when operating with a main clock rate of 14.32 MHz at 3V and all I/O configured to the high-Z state. Lowering clock frequency reduces active power consumption, although Sensory Speech 7 technology typically requires a 14.32 MHz clock.

Two supply current power-down modes are available – Sleep and Idle modes. In Sleep mode everything is stopped, and only an I/O event can initiate a wake-up. In Idle mode OSC2 and Timer2 continue to run, and an Audio Wakeup, I/O Wakeup or Timer2 interrupt request caused by overflow can generate a wake-up.

Sleep mode is entered by setting register E8.Bit7=1 (“ckCtl” register; “pdn” bit), register E8.Bit0=1 (“osc1_off”) and register E8.Bit1=0 (OSC2 off). Idle mode is entered by setting register E8.Bit7=1, register E8.Bit1=1 (“osc2_on”) and register E8.Bit0=1. Setting register E8.Bit7=1 (“pdn”) freezes the processor, but does *not* insure that the DAC, Audio Wakeup, and the PWM are placed in the lowest possible current-consumption state. Software control must power these blocks down prior to setting “pdn” to “1”, according to the procedures indicated in “DAC”, “Audio Wakeup”, and “Pulse Width Modulator Analog Output” Sections. The “Sensory Speech 7 Technology Library Manual” provides sample code for achieving the lowest current-consumption state for Sleep and Idle modes. The state of “pdn” bit may be observed externally on the PDN pin (see pin definitions in “Package Options” section) and used to control power down of circuitry external to the RSC-4128, if desired.

NOTE: GPIO (Ports 0,1 & 2) should be put in input mode and a known state (e.g. light pull-up) whenever possible to conserve power, and especially in powerdown mode to achieve the specified minimum supply current consumption. The external memory interface (A[19:0], D[7:0], -RDR, -WRC, -RDF and -WRD) automatically goes into a high-Z state and is pulled up by a 100 Kohm internal resistor when the “pdn” bit is set, to conserve current.

Register E8 contains both the “pdn” bit and the processor clock selector (Bit2). The clock selector bit determines whether the 14.32 clock (“fast clock”) or the 32KHz clock (“slow clock”) will be used at wakeup time, independent of what clock rate was being used before or during power down mode. This allows the processor clock *after wakeup*

to be the same or different from the processor clock used when the power-down flag was set. (see “Clock” section for complete explanation)

To minimize power consumption, most operational blocks on the chip also have individual power controls that may be selectively enabled or disabled by the programmer.

Wakeup from powerdown

Note that a Wakeup event does not cause a reset. The processor, which was “frozen” when register E8.Bit7 was set, will be restarted without loss of context. A reset of the chip will also cancel a power down mode, but with a corresponding loss of processor context.

Wakeup events terminate a power-down state. In Sleep mode, only an I/O Wakeup event can initiate a wake-up. In Idle mode, an Audio Wakeup, I/O Wakeup or Timer2 interrupt request caused by overflow can generate a wakeup.

An I/O Wakeup is enabled by setting the bit(s) high in registers E9 or EA corresponding to the desired I/O pin(s) to be used for wakeup. E9 controls P0 wakeup enable and EA controls P1 wakeup enable. The polarity of the wakeup event is controlled by putting the appropriate port pin in input mode and writing the appropriate bit in the output register for that pin to the desired polarity. (see “General Purpose I/O” section for complete explanation) When the value on the wakeup pin equals the value in the output register a wakeup will occur.

A T2 Wakeup is enabled by setting register E8.Bit6 high. Then an overflow of timer T2 will generate an interrupt request, which in turn will trigger a wakeup event. Note that the Timer2 “irq” bit (register FE.Bit1) must be cleared prior to powering down to allow the wakeup interrupt request to occur. (the “Timers/Counters” section describes how timer T2 is configured)

An Audio Wakeup is generated by special circuitry that can detect several classes of sounds, even while in power-down mode. When the class of sound selected by the programmer is detected by this circuitry a wakeup event will occur. (see the “Audio Wakeup” section for more information)

General Purpose I/O

The RSC-4128 has 24 general-purpose I/O pins (P0.0-P0.7, P1.0-P1.7, P2.0-P2.7). Each pin can be programmed as an input with weak pull-up (~200kΩ equivalent device); input with strong pull-up (~10kΩ equivalent device); input without pull-up, or as an output with sufficient drive to light an LED. (See “DC Characteristics” section for I/O electrical characteristics.) This is accomplished by programming combinations of 48 bits of configuration registers assigned to the I/O pins.

Two control registers, A and B, are used to control the nature of inputs and outputs for each port. Registers E6 (“p0CtlA”) and E7 (“p0CtlB”), E2 (“p1CtlA”) and E3 (“p1CtlB”), and DE (“p2CtlA”) and DF (“p2CtlB”), are the control registers A and B for ports P0, P1 and P2, respectively. Each port pin’s I/O configuration may be controlled independently by the state of it’s corresponding bits in these registers. Control registers A and B together determine the function of the port pins as follows:

B bit	A bit	Port Pin Function
0	0	Input - Weak Pull-up
0	1	Input - Strong Pull-up
1	0	Input - No pull-up
1	1	Output

(For example, if register E7.Bit 4 is set high, and register E6.Bit 4 is low, then pin P0.4 is an input without a pull-up device.)

After reset, pins P0.0-P0.7, P1.0-P1.7, and P2.5-P2.7 are set to be digital inputs with weak pull-ups, and pins P2.0-P2.4 are configured as analog input pins with no pull-ups. Being reset as an input and lightly pulled to a known

(high) state ensures minimum power consumption as a default beginning. Sixteen of these pins (Ports P0 and P1) can also be configured as inputs to control IO Wakeup events. (see “Power and Wakeup Control” section).

P2.0, P2.1, P2.3, and P2.4 can be configured as comparator inputs. P2.2 can be configured as a comparator reference. Some or all of P2.0-P2.4 can be configured as digital inputs by the use of the “cmpCtl” register (register D4) Bits[2:0] (see “Comparator Unit” section)

Note: When configuring P2.0-P2.4 as digital inputs the associated weak pull-up should be selected as shown above.

P0.0 and P0.2 can be configured as External Interrupts (see “Interrupts” section). P0.1 can be configured in input mode as a gate for an external event counter. (See “Timers/Counters” Section)

Registers E5 (“p0In”) and E4 (“p0Out”), E1 (“p1In”) and E0 (“p1Out”), and DD (“p2In”) and DC (“p2Out”), provide paths for data input and data output on P0, P1 and P2, respectively. The input registers are actually buffers which record the value at the ports at the time they are read. The output registers latch the data written to them and express it on the ports when the ports are configured as an output.

Following is a summary of the general purpose I/O control registers:

Register		
0DCH	Read/Write	P2[0:7] (port 2) output register. Cleared by reset.
0DDH	Read	Port 2 input.
0DEH	Read/Write	Port 2 Control Register A. Cleared by reset.
0DFH	Read/Write	Port 2 Control Register B. Bits[7:5] cleared by reset. Bits[4:0] set by reset
0E0H	Read/Write	P1[0:7] (port 1) output register. Cleared by reset.
0E1H	Read	Port 1 input.
0E2H	Read/Write	Port 1 Control Register A. Cleared by reset.
0E3H	Read/Write	Port 1 Control Register B. Cleared by reset.
0E4H	Read/Write	P0[0:7] (port 0) output register. Cleared by reset.
0E5H	Read	Port 0 input.
0E6H	Read/Write	Port 0 Control Register A. Cleared by reset.
0E7H	Read/Write	Port 0 Control Register B. Cleared by reset.

GPIO during powerdown

GPIO should be put in input mode and a known state (e.g. light pull-up) whenever possible to conserve power, and especially in powerdown mode to achieve the specified minimum supply current consumption.

Memory Addressing

The RSC-4128 includes an external memory interface that allows connection with memory devices for storage of speaker-dependent speech recognition templates, audio record/playback data storage, extended durations of speech and music synthesis beyond the storage capabilities of on chip ROM, and code storage for the RSC4000 ROMless version. Thirty-four (34) pins are used to provide a bus interface between the processor and external ROM, EPROM, SRAM, or FLASH. (in die and 100LQFP versions; for RSC4128 64LQFP version, see Programmers Manual design notes) The RSC-4128 external memory interface has been improved for ATD-type memories. The external address lines remain stable during instruction cycles that access internal RAM or ROM. The -RDR and -RDF signals go high when not actively reading. The condition of the external data lines is weak pull-up when not accessing the external bus. (See “DC Characteristics” section for bus electrical characteristics.)

The RSC4x can address up to 2MBytes of a combination of internal ROM and/or external ROM, RAM or flash memories without additional decoding circuitry. This is accomplished with 16 address outputs, A[15:0], and up to 4 extended address outputs A[19:16]. There are two different memory spaces of up to 1MByte each: Constant/Code Space and Data Space. (“Constant” Space is referred to as “Const” space in assembly and C-Data space in C) Data Space can be read or written. Constant/Code Space is typically read-only.

Constant/Code Space

When reading, Constant/Code Space can be either internal to the chip or external. Typical uses of this space are for code storage, and SI recognition set and/or compressed speech constant data storage. When the -XM input pin is held low, Constant/Code Space is external to the chip when reading and -RDR is the read strobe. When the -XM pin is high, Constant/Code Space reads are always internal to the chip, and are limited to the physical size of the internal ROM.

When writing, -WRC is the write strobe regardless of the state of the -XM pin. Writing to Constant/Code Space requires the *MOVC* instruction, which is limited to the first 128KBytes of Constant/Code Space.

When reading Constant/Code Space, an application can access up to 1MByte. However, only the first 128KBytes can be used by the processor for program instructions (Code). The *MOVC* instruction can only read these first 128KBytes. These first 128KBytes are partitioned into 64Kbyte banks, called Code Bank 0 and Code Bank 1. (NOTE: Code using both banks up to 128KBytes must provide “mirror” code in both banks for routines such as Interrupt Service, etc, with protocols to track bank identity.) The *MOVX* instruction can read the full 1Mbyte. However, the *MOVC* is more efficient for reading Constants within the current Code Bank.

The entire 1MByte of Constant/Code Space can be read with the following conditions. The upper addresses A[19:16] are generated from Bits[3:0] of Extended Addressing Register (register D2):

- 1) The *MOVX* instruction is used to read and Bit 4 (“rw”) of Extended Addressing Register (register D2) is programmed to “0”.

The first 128KBytes (addresses 00000H-1FFFFH; Code Banks 0 & 1) can be accessed in two additional ways. For these two cases, addresses A[19:17] are forced to zero by the RSC4x, and A[16] is generated from Bit 5 (“cb1”) of the Extended Addressing Register. A “0” in “cb1” selects Code Bank 0 and a “1” selects Code Bank 1:

- 2) The processor fetches instructions from the active Code Bank.
- 3) The *MOVC* instruction is used to read from or write to the active Code Bank.

Data Space

Data Space is always external to the chip and can be up to 1MByte. Typical uses of this space are for storage of SD recognition template data and/or recorded audio data, and frequently the data is volatile. –RDF is the read strobe and –WRD is the write strobe. A special bit in the Extended Addressing Register must be set high to allow the processor to read from the data space using the *MOVX* instruction. When the “rw” bit (Bit 4 of Register D2) is set, the *MOVX* instruction reads from the Data Space.

When writing to Data Space, the *MOVX* instruction generates a –WRD strobe, regardless of the state of the “rw” bit.

Data space can be accessed in two ways. For both cases, upper addresses A[19:16] are generated from bits [3:0] of Extended Addressing Register:

- 1) The *MOVX* instruction is used to read and bit 4 (“RW”) of Extended Addressing Register (register D2) is programmed to “1”.
- 2) The *MOVX* instruction is used to write.

Extended Address Register

0D2H R/W ExtAdd

Bit [7:6] (Unused)

Bit 5 cb1

- 0: *MOVC* reads/writes and processor fetches access addresses 00000H-0FFFFH of Constant/Code Space (Code Bank 0)
- 1: *MOVC* reads/writes and processor fetches access addresses 10000H-1FFFFH of Constant/Code Space (Code Bank 1)
Cleared on reset.

Bit 4 rw

- 0: *MOVX reads* access Constant/Code Space
- 1: *MOVX reads* access Data Space
Cleared on reset.

Bits [3:0] “eda” bits – extended address bits [19:16] used by *MOVX* to generate addresses bits A[19:16] of Data and/or Constant/Code Space.
Cleared on reset.

The programming of the Extended Addressing Register(“extAdd”) is independent of whether the ROM is external or internal. That is, an external ROM mirrors an internal ROM exactly. This allows products to be developed with external ROM and masked with the same binary in an internal ROM part.

Note: Unlike the RSC-3x, the last 256 bytes of Data Space are not allocated for internal processor functions. All internal processor functions are mapped to the SFR area of Register space, leaving all Data space addresses potentially accessible as external memory.

There are 8 data bus lines. These pins are bi-directional: they are normally inputs except when there is an external write to Code Space or Data Space. These pins, D[7:0], have weak pull-up devices (~100K ohm) to keep them from floating when no device is driving the data bus.

External Memory Interface Control Signals

There are 4 active low read/write strobes for reading from and writing to external Constant/Code Space or Data Space: -RDR, -WRC, -RDF, -WRD. To support cost effective software development for large memory spaces the external memory strobes are different from earlier RSC chips. The -RDR signal replaces the previous -RDC signal and the -RDF signal replaces the previous -RDD signal. The -XM pin replaces the previous -XML and -XMH pins on earlier RSC devices. The -WRC signal and the -WRD signal are the same as in previous RSC chips. (See "DC Characteristics" section for electrical characteristics.)

The 20-bit extended address for a memory-reference instruction or a code fetch may be directed to the internal ROM, or it may be directed to an external ROM or flash. The address is *always* an external address if:

- 1) the instruction is *MOVX* read *and* the "rw" bit is set, *or*
 - 2) the instruction is *MOVX* write, *or*
 - 3) the -XM pin is low, *or*
 - 4) the instruction is a *MOVC* write
- Otherwise the address is internal.

The -XM pin is an active low input pin that disables internal ROM when pulled low, and forces the use of external memory for Constant/Code Space. Write accesses to Constant/Code Space (*MOVC* write; -WRC active) are always directed off-chip. The -XM pin has a weak pull-up device (~10K ohm) to enable the internal ROM when no connection is made to this pin. At the end of reset -XM is sampled and, if pulled low externally, the internal 10K ohm pull-up device is disabled.

The -RDR signal goes low when the -XM pin is held low and *either*

- 1) the chip executes an instruction fetch, *or*
- 2) the chip executes a *MOVC* read instruction, *or*
- 3) the chip executes a *MOVX* read instruction *and* the "rw" bit is zero.

This active low signal is used to enable an external ROM or other external memory containing both executable code and fixed, read-only data.

The -RDF signal goes low when the chip executes a *MOVX* read instruction and the "rw" bit is set to 1. This active low signal is used to read an external flash or other external memory that is used solely for the purpose of Data Space, either read-only fixed data or read-write dynamic data.

The -WRD signal goes low when the processor executes a *MOVX* write instruction. The -WRC signal goes low when the processor executes a *MOVC* write instruction. These signals do not depend on the contents of the Extended Address Register or the -XM signal, since a write by definition cannot be done to internal ROM.

External Memory Interface during Powerdown

The external memory interface (A[19:0], D[7:0], -RDR, -WRC, -RDF and -WRD) automatically goes into a high-Z state and is pulled up by a 100 Kohm internal resistor when the "pdn" bit is set, to conserve current.

One output, PDN, is active high when RSC-4128 is powered-down. This pin can be connected to the (active low) chip enable pins of external memory devices to reduce power consumption during RSC-4128 power-down.

Wait States

General control of wait states is managed by register FC.Bits[7:5] ("bank" register). These bits are set to a value of 7 on reset, defaulting to slower memory. An initialization routine may be used to configure for faster memory.

Access of external ROM space is always controlled by these wait state bits. Internal ROM space and all external R/W space accesses may also controlled by these bits, unless otherwise selected by bits in the clock extension register (register D6, "clkExt") The internal RAMs always operate with zero wait states.

Register D6 provides for extended control of some clocks derived from OSC1 for producing additional timer scaling or specialized wait states. When Bit 5 is set, it overrides the "bank" register control of wait states during *MOVX* instructions which access external read/write memory (register D2.Bit4=1), and forces a fixed value of 4 wait states (nominal 350ns access). When Bit 7 is set, it overrides the "bank" register control of wait states during internal ROM accesses and forces zero wait states. Using these controls, various memory access speeds may be accommodated within one application.

- Bit 5 0: Certain *MOVX** instructions use the Wait State divisor in register FC.Bits[7:5]
 1: Certain *MOVX** use fixed 4 Wait States (nominal 350nsec access)
 Cleared by reset
- Bit 6 0: MT timer clock is disabled
 1: MT timer clock is enabled
 Cleared by reset
- Bit 7 0: Accesses to internal ROM use the Wait State divisor set in register 0FCh[7:5]
 1: Accesses to internal ROM use selected CLK (no wait states)
 Cleared by reset.

* *MOVX* accessing external read-write memory ("rw"; register D2.Bit4=1).

Instruction	Opcode	Operand 1	Operand 2	Description	Bytes	Cycles	+Cycles/ Waitstate
MOV	10	dest	Source	register to register	3	5	3
MOV	11	@dest	Source	register to register-indirect	3	5	3
MOV	12	dest	@source	register-indirect to register	3	6	3
MOV	13	dest	#immed	immediate data to register	3	4	3
MOVC	14	dest	@source	code space to register	3	7	4
MOVC	15	@dest	Source	register to code space	3	8	4
MOVX	16	dest	@source	data space to register	3	7	4*
MOVX	17	@dest	Source	register to data space	3	8	4*
POP	18	dest	@++source	register to register data stack pop (source pre- incremented)	3	10	3
PUSH	19	@dest--	Source	register to register data stack push (dest post- decremented)	3	9	3
MOVY	1A	dest	@source	RAMY to register, indirect	3	7	3
MOVY	1B	@dest	source	register to RAMY, indirect	3	7	3
MOVD	1C	dest_pair	source_pair	register to register, direct, 16-bit MOV	3	7	3

**MOVX* instructions will have the number of wait states selected by register FC.Bits[7:5], unless register D2.Bit4 and register D6.Bit5 are set, in which case the number of wait states is fixed at 4.

On-Chip ROM

The RSC-4128 includes integrated on-chip ROM. This ROM is enabled when the –XM pin is tied , or pulled high by it's own internal pullup resistor. This ROM space can combine both Code and Data.

ROM code Security Feature

The RSC-4128 has only one external memory enable pin (-XM), designed to prevent configuring code space for both internal and external memory. This discourages executing external code that reads internal code via the MOV_C instruction and dumps it externally. In this way, a substantial measure of security is provided for the developer's application code.

Oscillators

Two independent oscillators in the RSC-4128 provide a high-frequency oscillator (OSC1), and a 32 KHz time-keeping and power-saving oscillator (OSC2). The oscillator characteristics are:

OSC	FREQ	PLL	PINS	SOURCES
1	3.58 MHz	4X	XI1 XO1	Crystal Ceramic resonator LC
2	32768 Hz	N/A	XI2 XO2	Crystal Internal RC

OSC1

OSC1 is enabled by programming register E8.Bit0 to “0”, which is the reset state for this bit. This bit is also programmed to “0” during a Wakeup Event, enabling OSC1, if register E8.Bit2 is programmed to “0”. (see “Power and Wakeup Control” section) In this case, a 10-20 millisecond delay will be forced to allow OSC1 to reach stable oscillation. OSC1 must run at 3.58 MHz when using the Sensory Speech 7 technologies, but may be slower if the RSC-4128 is used as a general purpose platform for other applications. When OSC1 is disabled, the PLL which generates the 14.32MHz clock (CLK1) is also disabled.

OSC2

OSC2 is enabled by programming register E8.Bit1 to “1”. The reset state for this bit is “0”, so this oscillator is disabled by reset. OSC2 will be enabled during a Wakeup Event if register E8.Bit2 is programmed to “1”. (see “Power and Wakeup Control” section) No delay will be forced, as OSC2 is assumed to be running during Idle mode. The OSC2 source may be set to an external 32 KHz crystal by programming register EF.Bit2 to “0” (Note: register EF.Bit7 must be “0” to enable writing EF.Bit2) The external 32KHz crystal should be used when accurate timing and/or time-keeping is essential. In this mode, OSC2 is capable of achieving errors as low as 20ppm, depending on the quality of the crystal and crystal circuit design. A typical value for the crystal bias capacitors is 27pF, but this will vary depending on the crystal quality and stray capacitance inherent in the application board layout.

The OSC2 source may be set to an on-chip RC by programming register EF.Bit2 to “1” (Note: register EF.Bit7 must be “0” to enable writing EF.Bit2). When using the on-chip RC, no external components are required for OSC1. The on-chip RC value will vary due to process, temperature and supply voltage variations, so this oscillator frequency will vary by +/- 30%. The on-chip RC mode should be used for low power modes where timing is not critical and minimum system cost is important.

Oscillator Stabilization

When exiting Sleep mode (see “Power and Wakeup Control” section) OSC1 will have a forced 10-20millisecond delay for stabilization if it is enabled. If OSC2 is enabled, it may require several seconds to stabilize, after which the RSC4128 will begin running. Therefore, for fast response out of Sleep mode OSC1 should be enabled.

Clocks

The RSC-4128 uses a fully static core – the processor can be stopped (by removing the clock source) and restarted without causing a reset or losing contents of internal registers. Dynamic operation is guaranteed from ~1KHz to 14.32 MHz.

Fast Clock

The 3.58 MHz OSC1 frequency is quadrupled by an on-chip PLL to produce a 14.32 MHz internal clock (CLK1). Creating the internal clock in this way avoids an expensive high frequency crystal, substantially reducing overall system cost. When used as the processor clock (see below), the 14.32 MHz internal clock creates internal RAM cycles of 70 nsec duration, and internal or external Code/Data memory cycles of 140 nsec duration. Careful design may allow operation with memories having access times as slow as 140 nsec.

Slow Clock

OSC2 generates an internal clock (CLK2) with an equivalent frequency to OSC2. When used as the processor clock (see below), the RAM access cycles are one CLK2 cycle and Code/Data access cycles are two CLK2 cycles.

Processor Clock

Either CLK1 or CLK2 can be selected as the processor clock (PCLK) on the fly by changing the value of register E8.Bit2. The reset state defaults to CLK1. (NOTE: it is possible to select a disabled clock as the processor clock. It is the responsibility of the programmer not to select a clock until the corresponding oscillator has been enabled and allowed to stabilize.) Power savings may result by using CLK2 when the processor is a lower activity mode and using CLK1 when in a higher activity mode. If the use of an external clock driver is desired, the output of that driver should be connected to the XI1 pin.

After source selection, the processor clock can be divided-down in order to limit power consumption. Register E8.Bits 4 and 3 determine the divisor:

E8.Bit4	E8.Bit3	Processor Clock Divisor
0	0	1/2
0	1	1/1 (reset default)
1	0	1/8
1	1	1/256

A Processor Clock divisor of 1/1 is typically required for Sensory Speech 7 technology.

The processor clock is gated by the Wake-up delay and also gated by "pdn"=0 (register E8.Bit7), in such a way that the processor is stopped in a zero-power state with no loss of context.

Other System Clocks

The following functional clocks are generated from OSC1: CLK1, the digital filter clock, the analog front end (AFE) master clock, the L1 clock, Timer1 clock, Timer3 clock, and the Multi-Task timer clock. The Timer2 clock and the Watchdog timer clock are generated from OSC2. (see each block's section for clocking details) All clocks except the Timer2 and Audio Wakeup clocks are gated with the pdn = 0, to assure they are disabled during IDLE and SLEEP modes. Timer2 and Audio Wakeup can run during Idle mode to produce a T2 Wakeup or Audio Wakeup. (see "Power and Wakeup Control" section)

Timers/Counters

Four programmable timers and one fixed timer in the RSC-4128 provide a variety of timing/counting options. Timers 1, 2, 3 and the Multi-Tasking timer can all generate interrupts upon overflow. (See "Interrupts" section)

Timers 1 and 3

Each of Timer1 (T1) and Timer3 (T3) consists of an 8-bit reload value register, an 8-bit up-counter, and a 4-bit decoded prescaler register. Each is clocked by CLK1 divided by 16. The reload register is readable and writable by the processor. The counter is readable with precaution taken against a counter change in the middle of a read.

NOTE: If the processor writes to the counter, the data is ignored. Instead, the act of writing to the counter causes the counter to preset to the reload register value.

When the timer overflows from FFH, a pulse is generated that sets register FE.Bit 0 (“irq” register; T1 bit) or register FE. Bit 4(T3 bit). The width of the pulse is the pre-scaled counter clock period. Instead of overflowing to 00, the counter is automatically reloaded on each overflow.

For example, if the reload value is 0FAH, the counter will count as follows:

0FAH, 0FBH, 0FCH, 0FDH, 0FEH, 0FFH, 0FAH, 0FBH etc.

The overflow pulse is generated during the period *after* the counter value reaches 0FFH.

A separate 4-bit decoded prescaler register is between the clock source and the up-counter for each of T1 and T3. The 4bits represent the power of 2 used to divide the timer clock before applying it to the up-counter. For example, a prescaler value of 0 passes the timer clock directly through (divides by $2^0 = 1$). A prescaler value of 5 divides the timer clock by $2^5 = 32$.

Prescaler value	Divisor	Prescaler value	Divisor
0000	1	1000	256
0001	2	1001	512
0010	4	1010	1024
0011	8	1011	2048
0100	16	1100	4096
0101	32	1101	8192
0110	64	1110	16384
0111	128	1111	32768

The resolution of T1 and T3 is 8 bits, but the range is 23 bits. The longest interval that can be timed by T1 or T3 is $2^{15} \times 256$ clocks = 9.3 seconds.

The 4-bit prescaler for T1 is in the Clock Extensions Register, (register D6.Bits[3:0]). The 4-bit prescaler for T3 is in the Timer3 Control Register (register D9.Bits[3:0]).

In addition to its timing capability, T3 can also be configured as a counter of external events. In this configuration it uses either the rising or falling edge of a signal applied to I/O pin P0.1. The selected transition is internally synchronized to CLK1. The maximum external count rate for T3 is 447KHz.

The Timer3 Control Register contains the counting/timing options for T3. The register is write-only. Bits[6:4] provide configuration control.

Bit6	Bit5	Bit4	timer source	Configuration
x	0	0	T3CLK	timer
0	0	1	T3CLK	timer gated by P0.1 LOW
1	0	1	T3CLK	timer gated by P0.1 HIGH
0	1	x	P0.1	count P0.1 events, rising edge
1	1	x	P0.1	count P0.1 events, falling edge

Bit 7 0: disable T3 and prescaler from counting/timing
 1: enable T3
 cleared by reset.

Bit 6 0: use rising edge for external event counting
 use LOW state on pin P0.1 for timer gating
 1: use falling edge for external event counting
 use HIGH state on pin P0.1 for timer gating

	cleared by reset
Bit 5	0: use internal T3CLK for source (timing) 1: use external events on pin P0.1 for source (counting) cleared by reset
Bit 4	0: normal operation 1: T3 is gated by pin P0.1 according to Bit6 cleared by reset.
Bit 3:0	Encoded prescaler for T3. (See prescaler table above). cleared by reset.

T1 and T3 can generate interrupts upon overflow by setting register FD.Bit0=1 and Bit4=1, respectively. (see “Interrupts” section)

Timer2

Timer2 (T2) is clocked by CLK2 divided by 128. The overflow pulse from T2 can cause an interrupt request which in turn will cause a T2 Wake-up from power-down, if register E8.Bit6=1. (see “Power and Wakeup Control” section). Note that the Timer2 “irq” bit (register FE.Bit1) must be cleared prior to powering down to allow the wakeup interrupt request to occur. T2 can also generate a standard interrupt request by setting register FD.Bit1=1. (see “Interrupts” section)

Timers 1, 2 and 3 Timer Reload and Counter Registers

All are cleared to zero on reset.

Register	addr		
t1r	EBH	Read/Write	Timer1 Counter Reload (2's complement of period)
t1v	ECH	Read	Timer1 current counter value
		Write	Force load of Timer1 counter from reload register
t2r	EDH	Read/Write	Timer2 Counter Reload (2's complement of period)
t2v	EEH	Read	Timer2 current counter value
		Write	Force load of Timer2 counter from reload register
t3r	DAH	Read/Write	Timer3 Counter Reload (2's complement of period)
t3v	DBH	Read	Timer3 current counter value
		Write	Force load of Timer3 counter from reload register

Multi-Task Timer

The multi-tasking (MT) timer is intended to count a fixed interval of 858.1 microseconds. This provides a “heartbeat” for multi-tasking in the Sensory Speech 7 technology library. Other applications may find this useful for similar purposes. This interval is obtained by dividing the CLK1 rate, when running at 14.32 MHz, by a fixed factor of 12288. There is no configurability to the MT timer. One bit in the Clock Extension Register (D6.Bit6) enable this timer's clock. The MT timer overflow can generate an interrupt by setting register FD.Bit7=1. (see “Interrupts” section)

Watchdog Timer

Due to static electricity, voltage glitches, or other environmental conditions (or program bugs!), a software program can begin to operate incorrectly. The watchdog timer provides protection from such errant operation.

The Watchdog Timer (WDT) unit comprises two control bits in the System Control Register (D5), a special instruction, two status bits, and a 17-bit counter. The counter, driven by OSC2, produces a toggle rate of approximately 4 seconds at the 17th bit. A 2-bit decoded mux in the “sysCtl” register (register D5) allows selecting the WDT timeout pulse from bit 9, 13, 15, or 17 of the counter. This selection sets the timeout in the range of

approximately 15.6 msec to 4 seconds. The accuracy of these times will depend on whether the OSC2 source is a 32 KHz crystal or the on-chip RC.

The WDT is enabled by register FB.Bit4=1. This bit can only be set by execution of the “WDC” instruction. This bit is cleared by reset, so the WDT is disabled by reset. The bit is also cleared when E8.Bit7=1 (pdn), so the WDT is disabled in either SLEEP or IDLE mode. It is not automatically re-enabled on Wakeup. Program control cannot write to register FB.Bit4 to enable or disable the WDT. That is, FB.Bit4 is a read-only bit for normal register access instructions. Since the WDT needs OSC2 for its operation, once the WDC instruction has been executed and register FB.Bit4=1 to enable the WDT, OSC2 cannot be disabled by programming register E8.Bit1 =0 unless the “pdn” bit (register E8.Bit7) is also set simultaneously. This allows disabling the WDT only when entering a power down mode and is intended to reduce the probability of accidental software disabling of the WDT in active mode.

Executing the WDC instruction clears the WDT counter, sets register FB.Bit4=1, clears register FB.Bit5=0 (wd_timed-out), and starts a new timeout period. The OSC2 oscillator may also be enabled by executing the WDC instruction. If the oscillator is stopped, executing this instruction also sets register E8.Bit1=1 to enable OSC2. In this case, timing will not begin until the oscillator is active.

Once the WDT is started, software must execute the WDC instruction at a rate faster than the timeout period. Otherwise the watchdog circuit sets the “watch dog timed out” bit (register FB.Bit5) and generates a Timed Out Reset, which resets the RSC-4128. A Timed Out Reset disables the WDT. (See “Reset” section) Software in the reset routine can detect that the WDT timed out (FB.Bit5=1), since that is preserved during the Timed Out Reset. Placing the chip in Sleep or Idle mode disables the WDT operation.

Timer Powerdown

Some timers have independent power down control, while others may only be powered down by turning off their clock source, setting the “pdn” bit, or resetting. It is not required for the application to do this for full chip power down, as long as it complies with directions in the “Power and Wakeup Control” section. However, one may choose to reduce power consumption in active mode by turning off individual timers.

Timer 3 and MT Timer may be independently powered down by setting the register D9.Bit 7 to “0” (“t3Ctl” register, “t3_on” bit) and register D6.Bit 6 to “0” (“clkExt” register, “MTclk_on” bit), respectively.

Timer 1, Timer 2 and the WDT require special circumstances to powerdown, which are appropriate for their application. See their respective descriptions for more detail.

Interrupts

The RSC-4128 allows for 8 interrupt request sources, as selected by software. All are asynchronous positive edge activated except the two external requests, which have programmable edges. Each has its own mask bit and request bit in the “imr” and “irq” registers respectively. There is a Global Interrupt Enable flag in the “flags” registers. The “imr” and “irq” bits are listed below with the RSC-4128 interrupt source shown in parenthesis:

0FDH “imr”

- Bit 7: 1= enable interrupt request #7 (Overflow of MT timer)
- Bit 6: 1= enable interrupt request #6 (Edge of P0.2)
- Bit 5: 1= enable interrupt request #5 (Block End)(Reserved for Technology code)
- Bit 4: 1= enable interrupt request #4 (Overflow of Timer3)
- Bit 3: 1= enable interrupt request #3 (Edge of P0.0)
- Bit 2: 1= enable interrupt request #2 (Filter End Marker)(Reserved for Technology code)
- Bit 1: 1= enable interrupt request #1 (Overflow of Timer2)
- Bit 0: 1= enable interrupt request #0 (Overflow of Timer1)

0FEH “irq”

- Bit 7: 1=interrupt request #7 (Overflow of MT Timer)
- Bit 6: 1= interrupt request #6 (Edge of P0.2)
- Bit 5: 1=interrupt request #5 (Block End)(Reserved for Technology code)
- Bit 4: 1= interrupt request #4 (Overflow of Timer3)
- Bit 3: 1= interrupt request #3 (Edge of P0.0)

Bit 2: 1= interrupt request #2 (Filter End Marker)(Reserved for Technology code)
 Bit 1: 1= interrupt request #1 (Overflow of Timer2)
 Bit 0: 1= interrupt request #0 (Overflow of Timer1)

If an “irq” bit is set high and the corresponding “imr” bit is set high and the Global Interrupt Enable (“gie”; register FF.bit0) bit is set high, an interrupt will occur. Interrupts may be nested if software handles saving and restoring the “flagsHold” register (register CF). The “flags” register is copied to the “flagsHold” register and then the Global Interrupt Enable is cleared, preventing subsequent interrupts until the IRET instruction is executed. The IRET instruction will restore the “flags” register from the “flagsHold” register. The Global Interrupt Enable bit in the “flags” register must not be re-enabled during the period after an interrupt has been acknowledged and before an IRET instruction has been executed unless interrupt nesting is desired.

If an interrupt occurs during an instruction that clears the Global Interrupt Enable bit (typically the CLI instruction) the value of the “gie” bit will be 0 upon completion of the Interrupt Service Routine and Return From Interrupt to the instruction following the one that cleared the “gie” bit. (NOTE: This is a change from the operation of the RSC-364.)

The “flagsHold” register is accessible under program control at address CF in order to improve multi-tasking operation.

External interrupts may be enabled on pins P0.0 (1st external interrupt request) and P0.2 (2nd external interrupt request), by setting register FD.Bit3=1 and register FD.Bit6=1, respectively. The polarity of the edges to trigger an external interrupt request for P0.0 and are controlled by register D5.Bits[1:0]. Setting D5.Bit0=0 will cause a positive going edge on P0.0 to generate an interrupt and D5.Bit0=1 will cause a negative going edge to generate an interrupt. The same controls for P0.2 are possible with D5.Bit1. The corresponding external “irq” flag will be set if the transition matches the interrupt edge control bit.

NOTE: If P0.0 or P0.2 are configured as outputs, writing to those outputs can trigger external interrupt requests if the proper edge polarities occur. The user must be careful to avoid this, unless it is intended to use this as a way of generating interrupt requests under internal software control.

An interrupt is disabled by writing a zero to the corresponding bit in the imr register (register 0FDH). However, an active interrupt request can still be pending. To be certain that an interrupt does not happen, you should clear the interrupt request flag in the irq register (register 0FEH) as well. For example:

```
; Disable timer 1 interrupt

cli
and   imr,#0FEH    ; mask new interrupt requests
mov   irq,#0FEH    ; clear any pending interrupt request
sti
```

For each interrupt, execution begins at a different address:

Interrupt #0	Address 04H	(Overflow of Timer 1)
Interrupt #1	Address 08H	(Overflow of Timer 2)
Interrupt #2	Address 0CH	(Filter End Marker)(Reserved for Technology code)
Interrupt #3	Address 10H	(Edge of P00)
Interrupt #4	Address 14H	(Overflow of Timer 3)
Interrupt #5	Address 18H	(Block End)(Reserved for Technology code)
Interrupt#6	Address 1CH	(Edge of P02)
Interrupt#7	Address 20H	(Overflow of MT timer)

The interrupt vector is generated as a 20-bit address. The low 16 bits are derived from the execution table above, and the high 4 bits are selected as a normal code fetch as described in the “Memory Addressing” section. Specifically, the “cb1” bit is not touched by the interrupt.

If the corresponding mask register bit is clear, the “irq” bit will not cause an interrupt. However, it can be polled by reading the “irq” register.

“irq” bits can be cleared by writing a “0” to the corresponding bit at register FE (the “irq” register). “irq” bits cannot be set by writing to register FE. Writing a “1” to that register is a NO-OP.

NOTE: Bit2 and Bit5 of the “irq” register should always be written as “1” when clearing other “irq” bits, to avoid conflicts with the Technology code use of these bits.

In Idle mode, Timer2 continues to operate even when the rest of the RSC-4128 is powered-down. An overflow from Timer2 will set the corresponding “irq” flag even when there is no clock input to the processor. Note that the Timer2 “irq” bit (register FE.Bit1) must be cleared prior to powering down to allow the wakeup interrupt request to occur. This may also lead to normal interrupt processing once the processor is active, if the Timer 2 “imr” bit is set (register FD.Bit1). This interrupt response is unique from, and may be in addition to, the T2 Wakeup.

Analog input

The analog front end (AFE) for the RSC-4128 consists of a preamplifier with gain control, a 16-bit analog-to-digital converter, digital decimator and channel filters, and associated references. A single analog input can be processed through the AFE. All of this circuitry can be powered down to conserve battery life by programming register EF.Bit0 to “0”. Setting this bit to “1” powers up the circuitry, requiring a settling time of approximately 10milliseconds.

The analog front end (AFE) performs analog to digital conversions on a low-level signals, which may be derived from an electret microphone. The microphone signal is amplified by a preamp that provides four levels of gain, which are selected by programming register D5.Bits[4:3]. Full-scale output for the four settings corresponds to input signals of 100, 50, 25, and 12.5 millivolts V_{peak-peak}, as shown in the table below.

Gain “sysCtl” Bits[4:3]	Input Referred Noise μVrms	Max Input Signal	
		mVp-p	mVrms
00	5.2*	100	35.4
01	4.9*	50	17.7
10	4.6*	25	8.8
11	4.4	12.5	4.4

Input signals higher than specified will produce a saturated full scale output with no wrap around. A line level audio input must be attenuated to the range shown above for use with the AFE.

Digital Transfer Functions

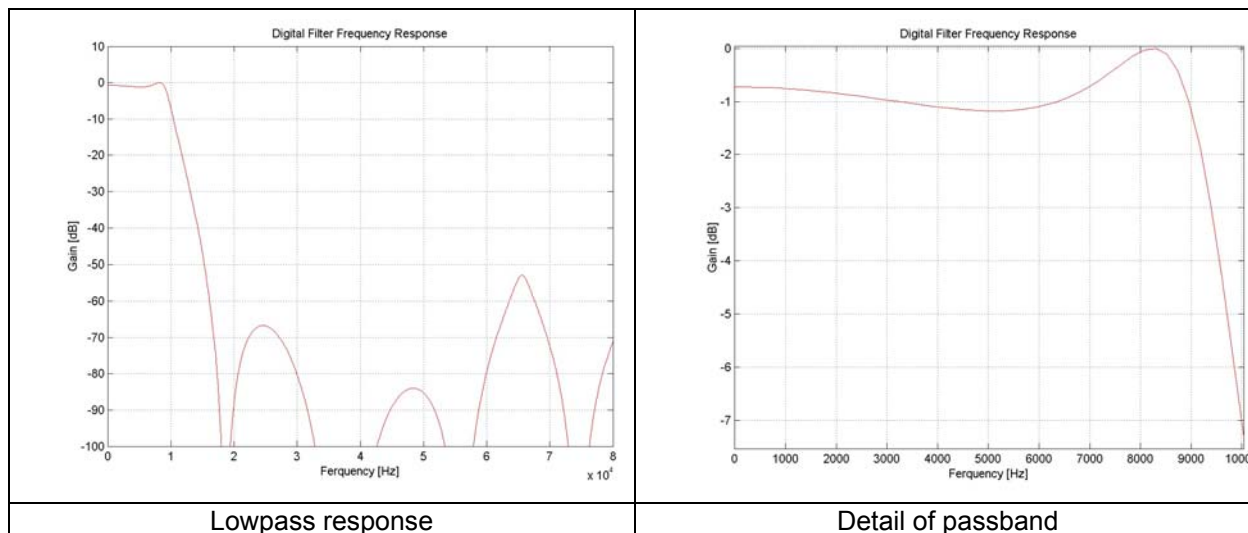

Frequency	Attenuation	
	Min	Max
Below 8 kHz	0	1.18
9.395 kHz	3 dB	
20 kHz	87.82	
Above 20 kHz	53	

NOTE: A 1uF capacitor should be connected to AMPCOM and tied to GND, a 2.2uF should be connected to VCM and tied to GND, and a 0.1uF capacitor should be connected to VREF and tied to GND. Failure to connect this capacitors will substantially degrade ADC performance, and Sensory Speech 7 technology.

A/D Conversion

The amplified signal is processed by a delta-sigma A/D converter that provides a 1-bit over-sampled digital signal. This digital stream is filtered and decimated to produce 16-bit samples at the fixed rate of 18,636 samples per second. The 16 bit signal will have about 12.5 bits of dynamic range, with about 10 bits above the noise level. These samples are then provided to the RSC-4128 digital filter unit formatted as signed two's-complement 16-bit values. The samples are stored in the digital filter input registers "adcSampleHi" (register F5) and "adcSampleLo" (register F4).

Note: Using the AFE for general purposes other than as intended in Sensory Speech 7 technology modules may conflict with Sensory Speech 7. Such conflicts may adversely impact Sensory Speech 7 functionality and/or the functionality of the general purpose application. Care should be taken to avoid such conflicts. Contact Sensory Technical Support for help in this area.

Audio Wakeup

The Audio Wakeup unit is an analog/digital circuit that can be configured to wakeup from one of four specific audio events:

- 1) Two handclaps, or any two sharp, closely spaced sounds
- 2) Three handclaps, or any three sharp, closely spaced sounds
- 3) A whistle
- 4) Any "loud" sound above a specified amplitude, with duration options of 1 or 2 seconds

Because it is intended to “listen” continuously at very low power levels, the Audio Wakeup unit must detect each of these events without any processor interaction. The processor configures and enables the unit under program control before going into Idle mode. Audio Wakeup is not available in Sleep mode because the unit requires the CLK2 signal. The detection signal from the Audio Wakeup unit can trigger a wakeup event, which starts the processor and allows further audio processing. The processor inputs to the Audio Wakeup are an enable signal and control signals to select for which sound to listen. For the lowest power consumption, the microphone should have a separate power source when in the Audio Wakeup mode. This is implemented outside the RSC-4128. See schematic 1-2 for details on this implementation.

Schematic 1-2

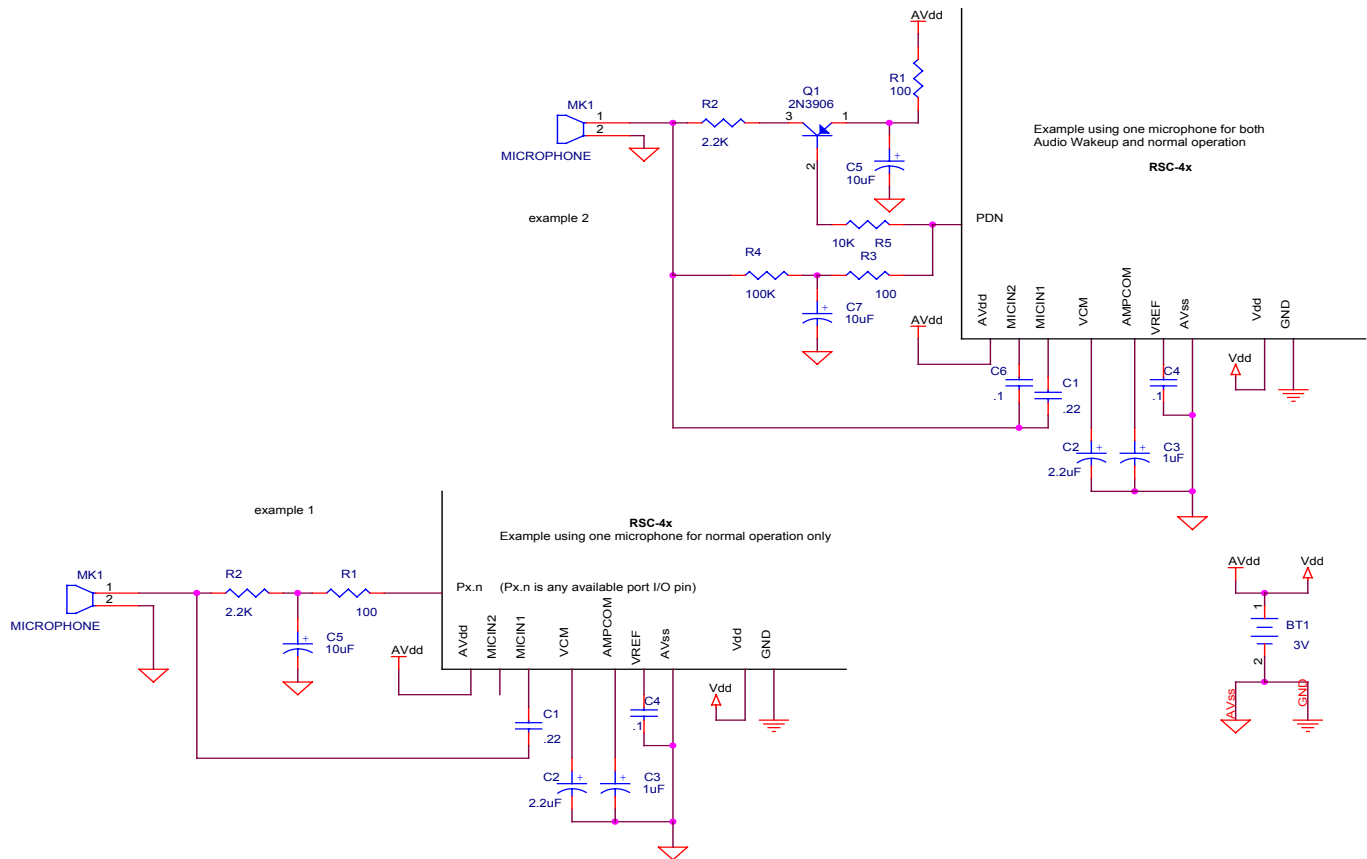

The RSC-4128 Sensory Speech 7 library contains routines for detecting each of the four audio events listed above. These routines also manage powerdown appropriately. See the “Sensory Speech 7 Technology Library Manual” for reference code to invoke these routines.

Microphones

A single electret microphone may be used both for the analog front-end input (for recognition purposes) and as the sound source for the Audio Wakeup unit. The current consumption and frequency response requirements are different for the two uses, so two microphone input pads are provided: MICIN1 for the normal recognition input to the analog front-end, and MICIN2 for the Audio Wakeup. A common microphone ground is used for both the analog front-end and the Audio Wakeup unit.

In normal operation, the microphone would typically be powered from a source with an impedance in the range of 1-3 KOhms. In Audio Wakeup operation, the microphone source impedance must be in the range of 100 KOhms (“current starved”) to reduce current consumption. The switching of the microphone input source is controlled by external circuitry under program control. See schematic 1-2 for details on this implementation.

NOTE: See Design Notes - “Microphone Housing” and “Selecting Microphone” on the RSC-4x Demo/Evaluation CD. Improper microphone circuit and/or enclosure design will result in poor recognition performance.

Reset

An external reset is generated by applying a low condition for at least two clock cycles on -RESET, an active low Schmitt trigger input. The output of the Schmitt trigger passes through a 10 nsec glitch blocking circuit, followed by an asynchronous flip-flop. The output of the flip-flop generates active high reset throughout RSC-4128. The internal reset state is held for 20 msec (when clocked by a 14.32 MHz PCLK). The purpose is to allow the oscillator to stabilize and the PLL to lock before enabling the processor and the other RSC-4128 circuits.

External reset clears the Global Interrupt Enable flag and begins execution at address 0h. The special function registers will be cleared, set, or left as-is, as detailed in the “Special Function Registers Summary” section.

Watchdog Timeout Reset

A special Watchdog Timeout Reset is produced if the Watchdog Timer is enabled and the Watchdog counter times out. The only difference between the Watchdog Timeout Reset and an ordinary reset is that the “wd_timed” bit in the “sysStat” register (register FB.Bit5) is preserved as “1” for a Watchdog Timeout Reset

Digital-to-Analog-Converter (DAC) Output

The DAC consists of an R-2R network with 10 bits of resolution and an output impedance of approximately 11 Kohms. An external amplifier is required to drive a speaker when using the DAC. The specifications of that amplifier will determine the best choice of speaker impedance and the resulting volume.

The 10-bit resolution corresponds to an analog voltage range between 0V and Vdd minus 1 LSB (represented as “Vdd-”). At Vdd=3V, one LSB of the R-2R network corresponds to about 3 mV. For example:

R2R Value	DAC output; Vdd=3V
000H = 0v	0.000V
001H = 0v+	0.003V
200H = Vdd/2	1.500V
3FFH = Vdd-	2.997V

There are two DAC output modes, full-scale and half-scale. In full-scale mode the output voltage swings between 0v and Vdd-; in half-scale mode the output swings between Vdd/4 and 3Vdd/4 minus 1 LSB (roughly Vdd/2 +/- Vdd/4). Values written into the DAC hold register and certain Analog Control register bits are converted into analog voltages.

The DAC hold register (“dac”; register FA) presents an 8-bit *signed* value to the DAC unit. In full-scale mode, the 8 most significant bits are driven by the DAC hold register and the 2 least significant bits are driven by the LSB1 and LSB0 bits in the Analog Control register (“anCtl”; register EF.Bits[5:4]). This results in a total output range of -512 to +511. In half-scale mode the 8 middle bits of are driven by the DAC hold register, the most significant bit is generated automatically by sign extension, and the least significant bit is driven by bit LSB1 in the Analog Control register. This gives a total output range of -256 to +255. The half-scale mode is enabled by setting the mode bit (d2a_half) equal to “1” in register EF.Bit3. The tables below show a selection of values and the resulting output voltage.

Note: Register EF.Bit7 (“-anctlen”) must be “0” in the value being written to register EF, when writing EF.Bit2.

Full-Scale Mode (Output range 0v to Vdd- 1 LSB)

Decimal Equivalent	DAC hold reg[7:0] (hex)	Analog Cntrl [5:4] (binary)	Digital input	Analog Voltage output	
				General	0-3V (approx)
-512	80H	00	000H	0V	0.000V
-511	80H	01	001H	0V+ 1 LSB	0.003V
-510	80H	10	002H		0.006V
-509	80H	11	003H		0.009V
-508	81H	00	004H		0.012V
-2	FFH	10	1FEH		
-1	FFH	11	1FFH	Vdd/2- 1 LSB	1.497V
0	00H	00	200H	Vdd/2	1.500V
+1	00H	01	201H	Vdd/2+ 1LSB	1.503V
+2	00H	10	202H		
+3	00H	11	203H		
+4	01H	00	204H		
+510	7FH	10	3FEH		2.994V
+511	7FH	11	3FFH	Vdd- 1LSB	2.997V

The translation in Full-Scale mode is:

R2R[9] = dac[7] inverted

R2R[8:2] = dac[6:0]

R2R[1:0] = anCtl[5:4]

Half-Scale Mode (Output range Vdd/4 to 3Vdd/4- 1 LSB)

Decimal Equivalent	DAC hold reg[7:0] (hex)	Analog Cntrl [5:4] (binary)	Digital Input	Analog Voltage output	
				General	0-3V (approx)
-256	80H	0x	100H	Vdd/4	0.750V
-255	80H	1x	101H	Vdd/4+ 1 LSB	0.753V
-254	81H	0x	102H		0.756V
-253	81H	1x	103H		0.759V
-252	82H	0x	104H		0.762V
-2	FFH	0x	1FEH		
-1	FFH	1x	1FFH	Vdd/2- 1LSB	1.497V
0	00H	0x	200H	Vdd/2	1.500V
+1	00H	1x	201H	Vdd/2+ 1LSB	1.503V
+2	01H	0x	202H		
+3	01H	1x	203H		
+4	02H	0x	204H		
+254	7FH	0x	2FEH		2.244V
+255	7FH	1x	2FFH	3Vdd/4-1 LSB	2.247V

The translation in Half-Scale mode is:

R2R[9] = dac[7] inverted

R2R[8:1] = dac[7:0]

R2R[0] = anCtl[5]

DAC Power Control

The DAC has no explicit power control. It is turned off (placed into lowest current mode) by loading the value 80H into the DAC hold register, and 0 into the LSB1 and LSB0 bits of the Analog Control Register (register EF.Bits[5:4]).

Note: register EF.Bit7 (“-anCtl” must be “0” in the value being written to register EF, when writing EF.Bits[5:0].

Pulse Width Modulator (PWM) Analog Output

The PWM consists of circuitry to regulate the width of a pulse supplied to one of two outputs, PWM0 and PWM1, over a period of programmable duration. One or the other of the two outputs is held at ground and the other is driven with a pulse of programmable duration, giving “push-pull” drive. Both outputs have “low shoot-thru” transistors to reduce radiated EMI. Once programmed, the PWM produces outputs continuously until register values are changed. The PWM has both 8 and 10 bit modes. The PWM Control Register (“pwmCtl”; register D7) contains the PWM on/off control (Bit0), the sample period (Bits[3:2]), sample size selection controls (Bit5), and the two least-significant bits of the 10-bit output value (Bits[7:6]). The sample size defaults to 8 bits, with register D7.Bit5=0 (“tenBits”). A sample size of 10 bits is selected by setting “tenBits” =1. The PWM output impedance is approximately 11 Ohms. Of the standard speaker impedances available, an 8 ohm speaker will provide optimal volume when driven by the PWM.

The PWM contains two counters. The data value counter is programmed with the value programmed in the “pwmData” register (register D8) in 8-bit mode. In 10-bit mode the data value counter uses “pwmData” and appends Bits[7:6] of “pwmCtl” as the least significant two bits to create a 10 bit value. Output data always lags input by one PWM sample period. The sample period counter is fixed and counts to 128. The prescaler in the PWM control register (register D7.Bits[3:2]) determines the clock for both the data value counter and the sample period counter. The prescaler divides the 14.3 MHz clock by 4,6, or 7, resulting in a PWM frequency of 27.9 KHz, 18.6Khz and 15.97 KHz, respectively. The PWM restarts every sample period, at which time either PWM0 or PWM1 pulses high. The selected signal pulses high for a duration determined by the data value and then returns low. The non-selected signal remains low. The pulsed output selection is controlled by the sign of the data. When Bit 7 of the “pwmData” register is 0, PWM0 pulses high while PWM1 remains 0. When Bit 7 of the “pwmData” register is 1, PWM1 pulses high while PWM0 remains low. When the data value in “pwmData” is 0, both signals remain low. When the sample period count selected by programming Bits[3:2] of the “pwmCtl” register D7.Bit has been reached, the PWM restarts. The PWM hardware sample period and the software data value updating must be synchronized to avoid aliasing.

The following table shows the rates and pulse durations obtained for 8-bit mode (“tenBits” programmed to “0”) SOFTWARE NOTE: “Full scale” output for all prescaler values is obtained by setting the data value to 7FH, so 8-bit signed data can be output at any of the three rates without amplitude adjustment.

PWM timing for “tenBits”=0

Item	prescaler=4	prescaler=6	prescaler=7
nsec/clock (period clock)	280	420	490
CLK1 clocks per period	512	768	896
nsec/clock (sample clock)	280	420	490
PWM frequency	27.9 kHz	18.6 kHz	15.97 kHz
pulse for data=01	4 H / 508 L	6 H / 762 L	7 H / 889 L
pulse for data=7F	508 H / 4L	762 H / 6 L	889 H / 7 L

For 10-bit mode (“tenBits” programmed to “1”), the sample period counter counts a full 7-bits (128 counts), exactly as when TenBits is 0. The 14.3 MHz clock is divided by the prescaler value and supplied to the sample period counter. The data value counter is clocked by the 14.3 MHz clock divided by 2 for prescaler values 6 or 7, and is clocked directly by the 14.3 MHz clock when the prescaler value is 4. Table YY shows the rates and pulse durations obtained with TenBits set to 1. SOFTWARE NOTE: “Full scale” output is obtained with a different data value for each prescaler value. Only prescaler=4 supports a full 9-bit count (512), so true 10-bit signed data can be output only with prescaler=4. Otherwise the amplitudes must be adjusted to have maximum amplitude of 447 (prescaler=7) or 383 (prescaler=6). See “Additional considerations using the PWM for 10-bit Data” below.

PWM timing for TenBits=1

Item	prescaler=4	prescaler=6	prescaler=7
nsec/clock (period ctr)	280	420	490
CLK1 clocks per period	512	768	896

nsec/clock (data ctr)	70	140	140
PWM frequency	27.9 kHz	18.6 kHz	15.97 kHz
pulse for data=001	1 H / 511 L	2 H / 766 L	2 H / 894 L
pulse for data=17F	383 H / 129 L	766 H / 2 L	766 H / 130 L
pulse for data=1BF	447 H / 65 L	-- n/a --	894 H / 2 L
pulse for data=1FF	511 H / 1 L	-- n/a --	-- n/a --

Additional considerations using the PWM for 10-bit Data

The 14.3 MHz CLK1 clock rate of the RSC-4128 is not fast enough to provide PWM synchronization with 10-bit 8 kHz or 9.3 kHz data. To understand this, consider a PWM rate of 8 kHz (125 microsec). To output 10 bits (9 bits plus sign) during this interval, a source must provide 512 clocks, giving a source rate of $125000/512 = 244$ nsec. The CLK1 period is 70 nsec, so the relationship between the source clock and CLK1 is $244/70 = 3.5$, which is not an integer. So the source clock cannot be derived simply from CLK1.

The RSC-4128 application developer should address this issue by using a “near-10-bit” resolution, as follows. The TenBits bit is set in the “pwmCtl” register, and the prescaler is programmed to 7 to produce a PWM frequency of 15.98 kHz (62.57 microseconds). During this interval there will be $62570/70 = 894$ CLK1 clocks, or $894/2 (=447)$ data counter clocks. The number 447 thus represents the largest possible count that can be loaded into the data value counter. The range of allowable values is from -447 to $+447$. Any larger value would produce the same output of the PWM pulse “on” for the entire duration of the PWM period. Thus 447 represents “full scale” of the PWM. If all 10-bit data values are then scaled to a maximum of ± 447 , the PWM will provide full-scale swing and (close-enough) synchronization at 8 kHz. The actual number of bits in the data is $\log_2(447 - (-447)) = 9.8$ bits. The developer must ensure that the value programmed in the data value counter must not exceed the range of -447 to $+447$. Sensory Speech 7 provides PWM output utilities for speech and music that manage the PWM for the developer, if so desired. (See “Sensory Speech 7 Technology Library Manual”)

PWM powerdown

The PWM may be independently powered down by programming the register D7.Bit 0 to “0” (“pwmCtl” register, “pwm_on” bit). When the PWM is off, the PWM outputs PWM0 and PWM1 are in a high-Z state and pulled up by internal 10K resistors. The PWM must be explicitly turned off before setting “pdn” equal to 1 to achieve the lowest powerdown current.

Comparator Unit

The Comparator Unit consists of 2 analog comparators designated “A” and “B”, a programmable voltage reference, selection circuitry, and two registers – the Comparator Control register (“cmpCtl”) and the Comparator Reference (“cmpRef”). Register “cmpCtl” configures the comparator unit and provides the digital comparator outputs. Bits [2:0] are used to select from one of eight comparator configurations, in which some or all of P2.0-P2.4 may be analog or digital inputs. (See “RSC-4128 Comparator Unit” figure; “A” denotes analog input and “D” denotes digital input) Bits [3:0] are read-write.

Register “cmpRef” controls the Comparator Reference Voltage. The unit can provide level information under software control about 4 external analog signals. All external signals connected to the comparator inputs must be between Vss and Vdd.

Each comparator has two analog inputs, designated “+” and “-”, and one digital output. When the analog voltage on the “+” input is greater than the analog voltage on the “-” input, the digital output is a high level. This is indicated by a “1” in the “cmpCtl” register (register D4) Bits 7 & 6 for Comparators A and B, respectively. When the analog voltage on the “+” input is less than the analog voltage on the “-” input, the digital output is a low level. This is indicated by a “0” in the “cmpCtl” register (register D4) Bits 7 & 6 for Comparators A and B, respectively. Bits 7 and 6 are the comparator outputs and are “Read-Only” by the processor.

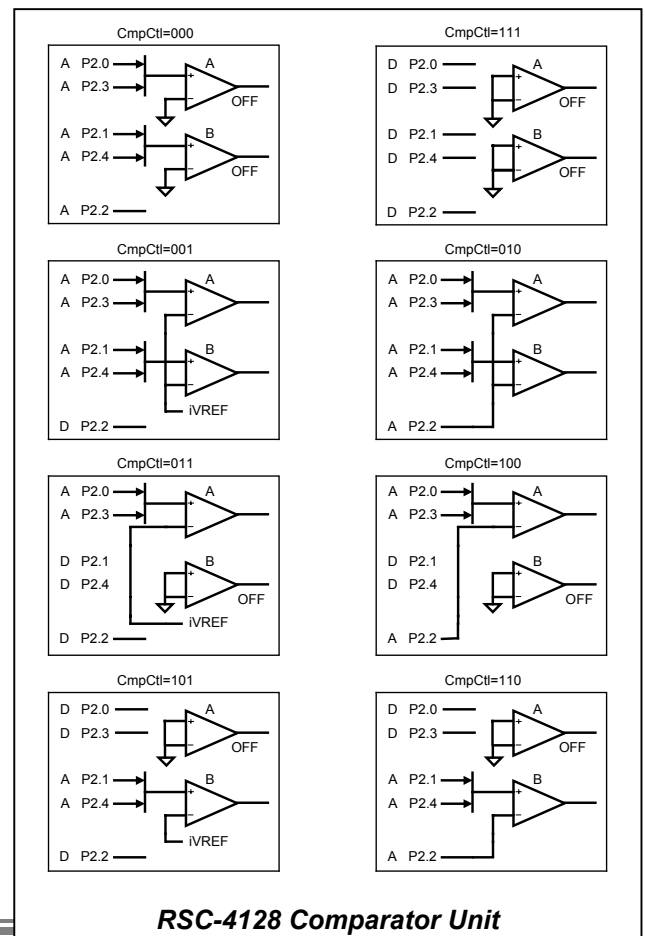

Each comparator can be separately enabled or disabled. When a comparator is disabled, both inputs are isolated from any circuitry common to both comparators, the inputs are grounded, and the comparator power is turned off.

Comparator Multiplexing

Each comparator “+” input has an analog multiplexer that selects between one of two external signals. When Bit3 of “cmpCt1” is programmed to “0”, comparator input A+ is multiplexed to P2.0 and input B+ is multiplexed to P2.1. When Bit3 of “cmpCt1” is programmed to “1”, comparator input A+ is multiplexed to P2.3 and input B+ is multiplexed to P2.4. The “-” inputs of both comparators are connected together. This common “-” input can be multiplexed to either an external comparator reference signal input through P2.2, or the Comparator Reference Voltage (CRV).

Comparator Reference Voltage

The internal Comparator Reference Voltage (CRV) is derived from a multi-tap resistive divider and a 4-bit analog multiplexer. Register “cmpRef” controls the Comparator Reference Voltage. The power for the Comparator Reference Voltage is provided by unregulated Vdd. This means that the CRV will track external voltages referenced from the system supply, giving consistent comparisons as the system supply drops. Power to the CRV is gated by decoding the comparator configuration. The voltage select value in “cmpRef” Bits[3:0] selects one of 16 outputs of an analog multiplexer connected to 16 equally spaced taps. The Comparator Reference Voltage covers the range from $0.15 \cdot V_{dd}$ to $0.90 \cdot V_{dd}$ in steps of $0.05 \cdot V_{dd}$ and is given by $0.15 \cdot V_{dd} + (D3[3:0]/20) \cdot V_{dd}$.

In some configurations the Comparator Control register can be set up once and simply read thereafter. In many configurations it will be necessary to switch the input multiplexers and/or re-program the reference voltage repeatedly. These multiplexing and selection operations will have settling times of approximately 10 microseconds.

When the “pdn” bit is set for Idle or Sleep mode the entire comparator unit is powered down, but the contents of the “cmpCt1” and “cmpRef” registers are preserved. When the RSC-4128 wakes up the comparators resume normal operation.

Instruction Set Opcodes and Timing Details

The RSC-4128 instruction set has 60 instructions comprising 13 move, 7 rotate/shift, 11 jump/branch, 13 register arithmetic, 9 immediate arithmetic, and 7 miscellaneous instructions. All instructions are 3 bytes or fewer, and no instruction requires more than 10 clock cycles (plus wait states) to execute. The column “Cycles” indicates the number of clock cycles required for each instruction when operating with zero wait states. Wait states may be added to lengthen all accesses to external addresses or to the internal ROM (but not internal SRAM). The column “+Cycles/Waitstate” shows the number of additional cycles added for each additional wait state. Opcodes are in HEX.

MOVE Group Instructions

Register-indirect instructions accessing code (*MOVC*), data (*MOVX*), technology (*MOVY*) or register (*MOV*) space locations use an 8-bit operand (“@source” or “@dest”) to designate an SRAM register pointer to the 16-bit target address. The “source” or “dest” indirect pointer register must be at an even address unless it is a 8-bit pointer (indirect *MOV*). The LOW byte of the target address is contained at the pointer address, and the HIGH byte of the target address is contained at the pointer address+1. Unless the flags register is the destination, the carry, sign, and zero flags are not affected by *MOV* instructions.

Instruction	Opcode	Operand 1	Operand 2	Description	Bytes	Cycles	+Cycles/Waitstate
MOV	10	dest	Source	register to register	3	5	3
MOV	11	@dest	Source	register to register-indirect	3	5	3
MOV	12	dest	@source	register-indirect to register	3	6	3
MOV	13	dest	#immed	immediate data to register	3	4	3
MOVC	14	dest	@source	code space to register	3	7	4
MOVC	15	@dest	Source	register to code space	3	8	4
MOVX	16	dest	@source	data space to register	3	7	4*
MOVX	17	@dest	Source	register to data space	3	8	4*
POP	18	dest	@++source	register to register data stack pop (source pre-incremented)	3	10	3

PUSH	19	@dest--	Source	register to register data stack push (dest post-decremented)	3	9	3
MOVY	1A	dest	@source	RAMY to register, indirect	3	7	3
MOVY	1B	@dest	source	Register to RAMY, indirect	3	7	3
MOVD	1C	dest_pair	source_pair	register to register, direct, 16-bit MOV	3	7	3

* If register D6.Bit 5=1 (movX_4ws) and external read/write memory is selected by setting the "rw" bit (register D2.Bit4), MOVX instructions have four additional wait states.

ROTATE Group Instructions

Rotate group instructions apply only directly to register space SRAM locations. The carry flag is affected by these instructions, but the sign and zero flags are unaffected.

Instruction	Opcode	Operand 1	Operand 2	Description	Bytes	Cycles	+Cycles/Waitstate
RL	30	dest	-	rotate left, c set from b7	2	5	2
RR	31	dest	-	rotate right, c set from b0	2	5	2
RLC	32	dest	-	rotate left through carry	2	5	2
RRC	33	dest	-	rotate right through carry	2	5	2
SHL	34	dest	-	shift left, c set from b7, b0=0	2	5	2
SHR	35	dest	-	shift right, c set from b0, b7=0	2	5	2
SAR	36	dest	-	shift right arithmetic, c set from b0, b7 duplicated	2	5	2

BRANCH Group Instructions

The branch instructions use direct address values rather than offsets to define the target address of the branch. This implies that binary code containing branches is not relocatable. However, object code produced by the RSC-4128 assembler contains address references that are resolved at link time, so .OBJ modules *are* relocatable. The indirect jump instruction uses an 8-bit operand (“@dest”) to designate an SRAM register pointer to the 16-bit target address. The “dest” pointer register must be at an even address. The LOW byte of the target address is contained at the pointer address, and the HIGH byte of the target address is contained at the pointer address+1.

Instruction	Opcode	Operand 1	Operand 2	Description	Bytes	Cycles	+Cycles/Waitstate
JC	20	dest low	dest high	jump on carry = 1	3	3	3
JNC	21	dest low	dest high	jump on carry = 0	3	3	3
JZ	22	dest low	dest high	jump on zflag = 1	3	3	3
JNZ	23	dest low	dest high	jump on zflag = 0	3	3	3
JS	24	dest low	dest high	jump on sflag = 1	3	3	3
JNS	25	dest low	dest high	jump on sflag = 0	3	3	3
JMP	26	dest low	dest high	jump unconditional	3	3	3
CALL	27	dest low	dest high	direct subroutine call	3	3	3
RET	28	-	-	return from call	1	2	1
IRET	29	-	-	return from interrupt	1	2	1
JMPR	2A	@dest	-	jump indirect	2	4	2

ARITHMETIC/LOGICAL Group Instructions

Arithmetic and logical group instructions apply only to Register Space SRAM locations. The results of the instruction are always written directly to the SRAM “dest” register. The exceptions are TM and CP instructions, which do not write the result to the “dest” register and only update the flags register based on the operation’s outcome. All but the INCRement and DECrement instructions have both register source and immediate source forms.

In each of the following instructions the sign and zero flags are updated based on the result of the operation. The carry flag is updated by the arithmetic operations (ADD, ADC, SUB, SUBC, CP, INC, DEC) but it is *not* affected by the logical operations (AND, TM, OR, XOR). Note: the carry is set **high** by SUB, CP, SUBC and DEC when a borrow is generated.

Instruction	Opcode	Operand 1	Operand 2	Description	Bytes	Cycles	+Cycles/Waitstate
AND	40	dest	source	logical and	3	6	3
TM	41	dest	source	like AND, destination register unchanged	3	6	3
OR	42	dest	source	logical or	3	6	3
XOR	43	dest	source	exclusive or	3	6	3
SUB	44	dest	source	subtract	3	6	3
CP	45	dest	source	like SUB, destination register unchanged	3	6	3
SUBC	46	dest	source	subtract w/carry	3	6	3
ADD	47	dest	source	add	3	6	3
ADC	48	dest	source	add w/carry	3	6	3
INC	49	dest	-	increment	2	5	2
DEC	4A	dest	-	decrement	2	5	2
AND	50	dest	#immed	logical and	3	5	3
TM	51	dest	#immed	like AND, destination register unchanged	3	5	3
OR	52	dest	#immed	logical or	3	5	3
XOR	53	dest	#immed	exclusive or	3	5	3
SUB	54	dest	#immed	subtract	3	5	3
CP	55	dest	#immed	like SUB, destination register unchanged	3	5	3
SUBC	56	dest	#immed	subtract w/carry	3	5	3
ADD	57	dest	#immed	add	3	5	3
ADC	58	dest	#immed	add w/carry	3	5	3
INCD	69	dest_pair & source_pair	-	register pair 16-bit increment	2	8	2
CPD	66	dest_pair	source_pair	16-bit compare	3	10	3

MISCELLANEOUS Group Instructions

Instruction	Opcode	Operand 1	Operand 2	Description	Bytes	Cycles	+Cycles/Waitstate
NOP	00	-	-	no operation	1	2	1
CLC	01	-	-	clear carry	1	2	1
STC	02	-	-	set carry	1	2	1
CMC	03	-	-	complement carry	1	2	1
CLI	04	-	-	disable interrupts	1	2	1
STI	05	-	-	enable interrupts	1	2	1
WDC	06	-	-	enable/restart Watchdog timer	1	2	1

Special Functions Registers (SFRs) Summary

Address	R/W	Name	Reset	Bit 7	Bit 6	Bit 5	Bit 4	Bit 3	Bit 2	Bit 1	Bit 0
FF	R/W	flags *****	0000 0000	carry	zero	sign	trap	stkoflo	stkfull	---	gie
FE	R/W	irq *	0000 0000	MTtimer	p0.2	block	timer3	p0.0	endmark	timer2	timer1
FD	R/W	imr ****	0000 0000	MTtimer	p0.2	block	timer3	p0.0	endmark	timer2	timer1
FC	R/W	bank	1110 0000	ws2	ws1	ws0	(bank4)	bank3	bank2	bank1	bank0
FB	W	RESERVED									
	R	sysStat	0000 0000	0	brownout	wd timed	wd on	0	0	fastClk	0
FA	R/W	dac	0000 0000	dh7	dh6	dh5	dh4	dh3	dh2	dh1	dh0
F9	R/W	RESERVED									
F8	R/W	RESERVED									
F7	R/W	stkData	0000 0000	stk7	stk6	stk5	stk4	stk3	stk2	stk1	stk0
F6	R/W	stkNdx	0000 0000	0	0	stkind5	stkind4	stkind3	stkind2	stkind1	stkind0
F5	W	RESERVED									
	R	adcSampleHi	0000 0000	adc15	adc14	adc13	adc12	adc11	adc10	adc09	adc08
F4	W	RESERVED									
	R	adcSampleLo	0000 0000	adc07	adc06	adc05	adc04	adc03	adc02	adc01	adc00
F3	R/W	RESERVED									
F2	R/W	RESERVED									
F1	W	RESERVED									
	R	RESERVED									
F0	R/W	RESERVED									
EF	W	anCtl ***	0000 0000	-anctlen	0	lsb1	lsb0	d2a_half	rc_osc2	0	afe_on
	R		0000 0000	-anctlen	0	lsb1	lsb0	d2a_half	rc_osc2	0	afe_on
EE	W	t2v **	0000 0000	x	x	x	x	x	x	x	x
	R	0000 0000		t2v7	t2v6	t2v5	t2v4	t2v3	t2v2	t2v1	t2v0
ED	R/W	t2r	0000 0000	t2r7	t2r6	t2r5	t2r4	t2r3	y2r2	t2r1	t2r0
EC	W	t1v **	0000 0000	x	x	x	x	x	x	x	x
	R	0000 0000		t1v7	t1v6	t1v5	t1v4	t1v3	t1v2	t1v1	t1v0
EB	R/W	t1r	0000 0000	t1r7	t1r6	t1r5	t1r4	t1r3	t1r2	t1r1	t1r0
EA	R/W	wake1	0000 0000	w1.7	w1.6	w1.5	w1.4	w1.3	w1.2	w1.1	w1.0
E9	R/W	wake0	0000 0000	w0.7	w0.6	w0.5	w0.4	w0.3	w0.2	w0.1	w0.0
E8	R/W	ckCtl *****	0000 1000	pdn	t2wake	fclk on	clk div1	clk div0	slow pclk	osc2 on	osc1 off
E7	R/W	p0CtlB	0000 0000	ctlb0.7	ctlb0.6	ctlb0.5	ctlb0.4	ctlb0.3	ctlb0.2	ctlb0.1	ctlb0.0
E6	R/W	p0CtlA	0000 0000	ctla0.7	ctla0.6	ctla0.5	ctla0.4	ctla0.3	ctla0.2	ctla0.1	ctla0.0
E5	R	p0In	xxxx xxxx	pin0.7	pin0.6	pin0.5	pin0.4	pin0.3	pin0.2	pin0.1	pin0.0
E4	R/W	p0Out	0000 0000	pout0.7	pout0.6	pout0.5	pout0.4	pout0.3	pout0.2	pout0.1	pout0.0
E3	R/W	p1CtlB	0000 0000	ctlb1.7	ctlb1.6	ctlb1.5	ctlb1.4	ctlb1.3	ctlb1.2	ctlb1.1	ctlb1.0
E2	R/W	p1CtlA	0000 0000	ctla1.7	ctla1.6	ctla1.5	ctla1.4	ctla1.3	ctla1.2	ctla1.1	ctla1.0
E1	R	p1In	xxxx xxxx	pin1.7	pin1.6	pin1.5	pin1.4	pin1.3	pin1.2	pin1.1	pin1.0
E0	R/W	p1Out	0000 0000	pout1.7	pout1.6	pout1.5	pout1.4	pout1.3	pout1.2	pout1.1	pout1.0
DF	R/W	p2CtlB	0000 0000	ctlb2.7	ctlb2.6	ctlb2.5	ctlb2.4	ctlb2.3	ctlb2.2	ctlb2.1	ctlb2.0
DE	R/W	p2CtlA	0000 0000	ctla2.7	ctla2.6	ctla2.5	ctla2.4	ctla2.3	ctla2.2	ctla2.1	ctla2.0
DD	R	p2In	xxxx xxxx	pin2.7	pin2.6	pin2.5	pin2.4	pin2.3	pin2.2	pin2.1	pin2.0
DC	R/W	p2Out	0000 0000	pout2.7	pout2.6	pout2.5	pout2.4	pout2.3	pout2.2	pout2.1	pout2.0
DB	W	t3v **	0000 0000	x	x	x	x	x	x	x	x
	R		0000 0000	t3v7	t3v6	t3v5	t3v4	t3v3	t3v2	t3v1	t3v0
DA	R/W	t3r	0000 0000	t3r7	t3r6	t3r5	t3r4	t3r3	t3r2	t3r1	t3r0
D9	W	t3Ctl	0000 0000	t3 on	polarity	p0.1 src	t3 gated	t3 ps3	t3 ps2	t3 ps1	t3 ps0
D8	R/W	pwmData	0000 0000	pwm09	pwm08	pwm07	pwm06	pwm05	pwm04	pwm03	pwm02
D7	R/W	pwmCtl	0000 0000	pwm01	pwm00	tenBits	0	period1	period0	0	pwm_on
D6	R/W	clkExt *****	0000 0000	rom 0Ws	MTclk on	movx 4ws	L1clk on	t1 ps3	t1 ps2	t1 ps1	t1 ps0
D5	R/W	sysCtl	0000 0000	wd ps1	wd ps0	brnout on	afe g1	afe g0	0	p02Edge	p00Edge
D4	W	cmpCtl	1100 0000	1	1	0	0	mux_sel	ccs2	ccs1	ccs0
	R		1100 0000	compA+	compB+	0	0	mux_sel	ccs2	ccs1	ccs0
D3	R/W	cmpRef	0000 0000	0	0	0	0	crv03	crv02	crv01	crv00
D2	R/W	extAdd	0000 0000	0	0	cb1	rw	eda19	eda18	eda17	eda16
D1	R/W	RESERVED									
D0	R/W	RESERVED									
CF	R/W	flagsHold *****	0000 0000	carry	zero	sign	trap	0	0	0	gie
CE	W	awcCtl	0000 0000	pwrl	0	thr2	thr1	thr0	thr12	thr11	thr10

Address	R/W	Name	Reset	Bit 7	Bit 6	Bit 5	Bit 4	Bit 3	Bit 2	Bit 1	Bit 0
	R		0000 0000	pwrl	detect	thrh2	thrh1	thrh0	thrl2	thrl1	thrl0
CD	W	RESERVED									
	R	RESERVED									
CC		RESERVED									
CB		RESERVED									
CA		RESERVED									
C9		RESERVED									
C8		RESERVED									
		RESERVED									
C7		RESERVED									
C6		RESERVED									
C5		RESERVED									
C4		RESERVED									
C3		RESERVED									
		RESERVED									
C2		RESERVED									
		RESERVED									
C1		RESERVED									
		RESERVED									
C0		RESERVED									
		RESERVED									

Reset: "x" = unknown/don't care, '-' = not implemented

* Only "0" can be written to "irq" bits. "1" is a "nop" for the bit to which it is written. When using Sensory Speech technology, always write "1" to "block" and "endmark" in the "irq" register to avoid conflicting with technology code control of these bits.

** Write value is ignored and reload register value is written instead.

*** -anctl (Bit7) of values written to the "anCtl" register must be "0" to enable writing the other bits in the value to "anCtl".

**** When using Sensory Speech technology, "fclk_on", "L1clk_on", and "block" and "endmark" in the "imr" register should be left at the values programmed by the technology code. A read-modify-write action should be used to modify the registers to avoid changing these bits.

***** "trap" must always be written as "0" in the "flags" and "flagsHold" registers

DC Characteristics

Operating Conditions ($T_O = 0^\circ\text{C}$ to $+70^\circ\text{C}$, $V_{DD} = 2.4\text{V} - 3.6\text{V}$)

SYMBOL	PARAMETER	MIN	TYP	MAX	UNITS	TEST CONDITIONS
V_{IL}	Input Low Voltage	-0.1		0.75	V	
V_{IH}	Input High Voltage	$0.8 \cdot V_{DD}$		$V_{DD} + 0.3$	V	
I_{IL}	Input Leakage Current		<1	10	μA	$V_{SS} < V_{pin} < V_{DD}$
I_{ACT}	Supply Current, Active		10		mA	Hi-Z Outputs, $V_{DD} = 3\text{V}$
I_{ACT}	Supply Current, Active			20	mA	Hi-Z Outputs, $V_{DD} = 3.6\text{V}$
I_{IDLE}	Supply Current, Idle		4	7	μA	Hi-Z Outputs
I_{SLEEP}	Supply Current, Sleep		1	4	μA	Hi-Z Outputs
R_{PU}	Pull-up resistance					
	P0.0-P0.7, P1.0-P1.7, P2.0-P2.7		10, 200, Hi-Z		$k\Omega$	Software selectable
	A0-A19, D0-D7, PLEN, -RESET, -RDR, -RDF, -WRC, -WRD		100		$k\Omega$	Fixed
	-XM, PWM0, PWM1		10		$k\Omega$	Fixed
R_{PO}	Pull-down resistance TEST		10		$k\Omega$	Fixed
I_{OL}	Output Low Current					
	A0-A19, D0-D7, -RDR, -RDF, -WRC, -WRD, PDN	4			mA	$V_{OL} = 0.5\text{V}$, $V_{DD} = 2.4\text{V}$
	P0.0-P0.7, P1.0-P1.7, P2.0-P2.7 PWM0, PWM1	8	180		mA	$V_{OL} = 0.5\text{V}$, $V_{DD} = 2.4\text{V}$ $V_{OL} = 0.8\text{V}$, $V_{DD} = 3.3\text{V}$
I_{OH}	Output High Current					
	A0-A19, D0-D7, -RDR, -RDF, -WRC, -WRD, PDN	-2.5			mA	$V_{OH} = 1.8\text{V}$, $V_{DD} = 2.4\text{V}$
	P0.0-P0.7, P1.0-P1.7, P2.0-P2.7 PWM0, PWM1	-5	-80		mA	$V_{OH} = 1.8\text{V}$, $V_{DD} = 2.4\text{V}$ $V_{OH} = 2.5\text{V}$, $V_{DD} = 3.3\text{V}$

A.C. Characteristics (External memory accesses)

Operating Conditions ($T_O = 0^\circ\text{C}$ to $+70^\circ\text{C}$, $V_{DD} = 3.3\text{V}$; load capacitance for outputs = 30pF)

SYMBOL	PARAMETER	PCLK=CLK1/1, 1WS		PCLK=CLK1/1, 0WS		UNITS
		MIN	MAX	MIN	MAX	
1/TCL1	Processor Clock frequency		14.32		14.32	MHz
TRLRH	-RDR (-RDF) Pulse Width		140		140	ns
TRLAV	-RDR (-RDF) Low to Address valid		5		5	ns
TALRAX	Address hold after -RDR (-RDF)		0		0	ns
TRAVDV	Address valid to Valid Data In		135		65	ns
TRHDX	Data Hold after -RDR (-RDF)	0		0		ns
TWLWH	-WRC (-WRD) Pulse Width		140		70	ns
TAVWL	Address Valid to -WRC (-WRD)	35		35		ns
TALWAX	Address Hold after -WRC (-WRD)	35		35		ns
TWDVAV	Write Data Valid to Address Valid		5		5	ns
TWHQX	Data Hold after -WRC (-WRD)	35		35		ns

Timing Diagrams

Note that the -RDR signal does not necessarily pulse for every read from code space, but may stay low for multiple cycles.

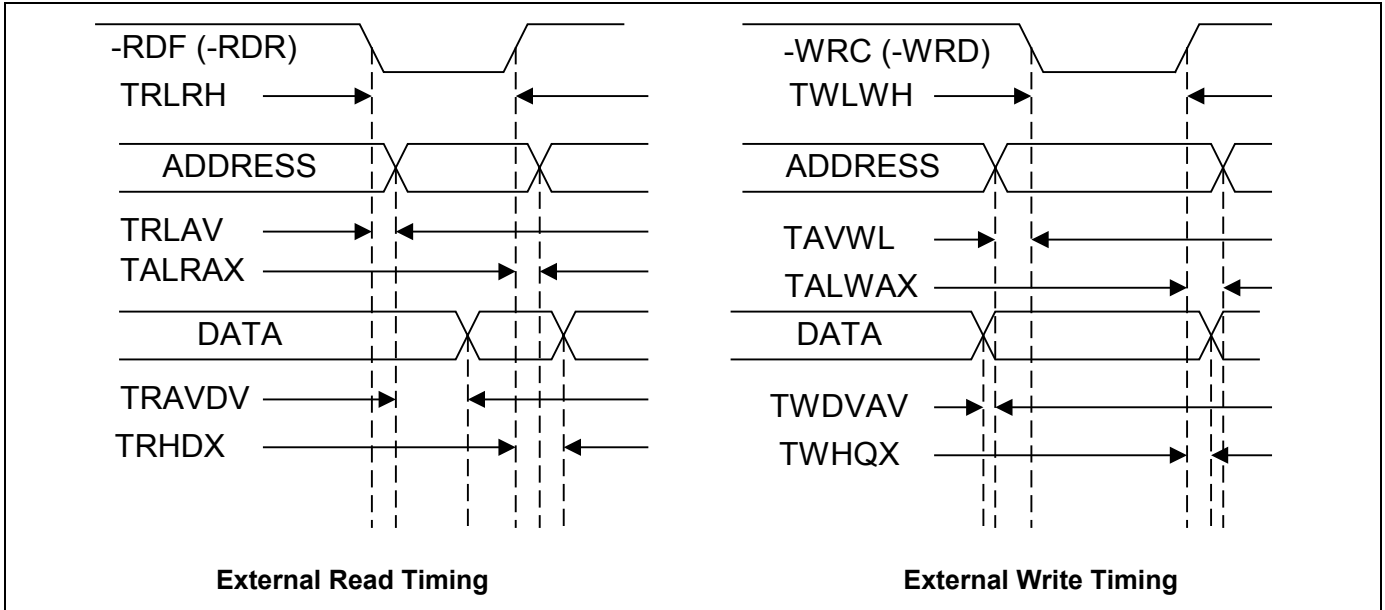

Absolute Maximum Ratings

Any pin to GND:	-0.1V to +4.0V
Storage temperature:	-65°C to +150°C
Operating temperature:	-40°C to +85°C
Soldering temperature:	260°C for 10 sec
Power dissipation:	1 W

WARNING:
 Stressing the RSC-4128 beyond the "Absolute Maximum Ratings" may cause permanent damage. These are stress ratings only. Operation beyond the "Operating Conditions" is not recommended and extended exposure beyond the "Operating Conditions" may affect device reliability.

Package Options

The RSC-4128 can be purchased in 100-lead LQFP or 64 lead LQFP packages, or in unpackaged die. When using an in circuit emulator (ICE) on dice applications, a COB bonding pad ring equivalent to a 100-lead LQFP footprint is advised for easy ICE adapter attachment.

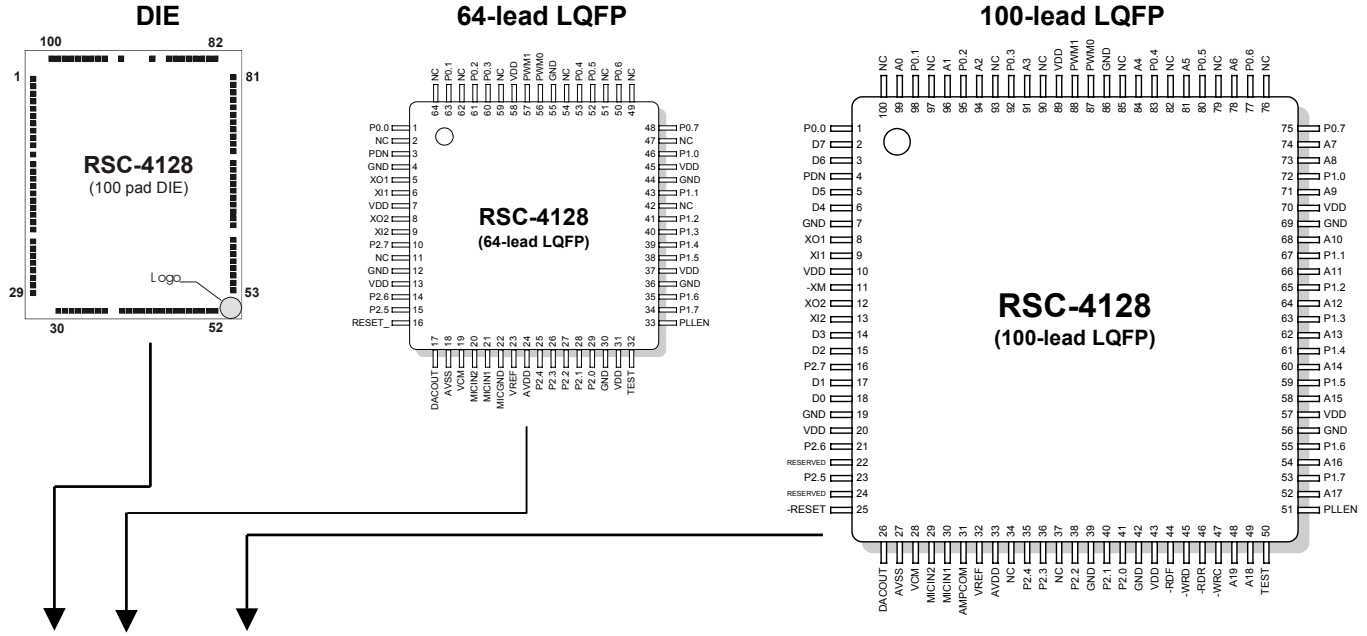

DIE Pad #	64 LQFP Pin #	100 LQFP Pin #	Pin Name	Description	Signal Type
1	1	1	P0.0	General Purpose I/O that can act as a "wake-up" input	I/O, 10k or 200k pull-up resistor; high-Z
2	2=NC	2	D7	External Data Bus (no connect for 64-lead LQFP)	I/O, 100k pull-up; high-Z
3	-	3	D6	External Data Bus	I/O, 100k pull-up; high-Z
4	3	4	PDN	Power Down (active high when powered down)	Output
5	-	5	D5	External Data Bus	I/O, 100k pull-up; high-Z
6	-	6	D4	External Data Bus	I/O, 100k pull-up; high-Z
7	4	7	GND	Ground	GND
8	4	7	GND	Ground	GND
9	5	8	XO1	Oscillator 1 output	Output
10	6	9	XI1	Oscillator 1 input	Input
11	7	10	VDD	Supply Voltage	PWR
12	7	10	VDD	Supply Voltage	PWR
13	-	11	-XM	External Memory Enable (active low)	Input, 10k pull-up resistor
14	8	12	XO2	Oscillator 2 output	Output
15	9	13	XI2	Oscillator 2 input	Input
16	-	14	D3	External Data Bus	I/O, 100k pull-up; high-Z
17	-	15	D2	External Data Bus	I/O, 100k pull-up; high-Z
18	10	16	P2.7	General Purpose I/O that can act as a "wake-up" input	I/O, 10k or 200k pull-up resistor; high-Z
19	11=NC	17	D1	External Data Bus (no connect for 64-lead LQFP)	I/O, 100k pull-up; high-Z
20	-	18	D0	External Data Bus	I/O, 100k pull-up; high-Z
21	12	19	GND	Ground	GND
22	12	19	GND	Ground	GND
23	13	20	VDD	Supply Voltage	PWR
24	13	20	VDD	Supply Voltage	PWR
25	14	21	P2.6	General Purpose I/O that can act as a "wake-up" input	I/O, 10k or 200k pull-up resistor; high-Z
26	-	22	reserved	DO NOT USE	DO NOT USE
27	15	23	P2.5	General Purpose I/O that can act as a "wake-up" input	I/O, 10k or 200k pull-up resistor; high-Z
28	-	24	reserved	DO NOT USE	DO NOT USE
29	16	25	-RESET	Reset (active low)	Input, 100k pull-up resistor
30	17	26	DACOUT	DAC output	Analog out
31	18	27	AVSS	Analog ground	(A) GND
32	19	28	VCM	Common mode reference	Analog
33	20	29	MICIN2	Microphone input for audio wakeup	Analog IN
34	21	30	MICIN1	Microphone input	Analog IN

DIE Pad #	64 LQFP Pin #	100 LQFP Pin #	Pin Name	Description	Signal Type
35	22	31	AMPCOM	Amplifier input common	Analog IN
36	23	32	VREF	Voltage reference	Analog OUT
37	24	33	AVDD	Analog Supply Voltage	(A) PWR
-	-	34	NC	Not connected	
38	25	35	P2.4	General Purpose I/O or comparator input	I/O, 10k or 200k pull-up resistor; high-Z
39	26	36	P2.3	General Purpose I/O or comparator input	I/O, 10k or 200k pull-up resistor; high-Z
-	-	37	NC	Not connected	
40	27	38	P2.2	General Purpose I/O or comparator reference	I/O, 10k or 200k pull-up resistor; high-Z
41	-	39	GND	Ground	GND
42	28	40	P2.1	General Purpose I/O or comparator input	I/O, 10k or 200k pull-up resistor; high-Z
43	29	41	P2.0	General Purpose I/O or comparator input	I/O, 10k or 200k pull-up resistor; high-Z
44	30	42	GND	Ground	GND
45	31	43	VDD	Supply Voltage	PWR
46	-	44	-RDF	External Data Read Strobe (active low)	Output, 100k pull-up resistor; high-Z
47	-	45	-WRD	External Data Write Strobe (active low)	Output, 100k pull-up resistor; high-Z
48	-	46	-RDR	External Code Read Strobe (active low)	Output, 100k pull-up resistor; high-Z
49	-	47	-WRC	External Code Write Strobe (active low)	Output, 100k pull-up resistor; high-Z
50	-	48	A19	External Memory Address Bus	Output, 100k pull-up resistor; high-Z
51	-	49	A18	External Memory Address Bus	Output, 100k pull-up resistor; high-Z
52	32	50	TEST	Test Mode	Input, 10k pull-down resistor
53	33	51	PLLEN	PLL Enable	Input, 100k pull-up resistor
54	-	52	A17	External Memory Address Bus	Output, 100k pull-up resistor; high-Z
55	34	53	P1.7	General Purpose I/O that can act as a "wake-up" input	I/O, 10k or 200k pull-up resistor; high-Z
56	-	54	A16	External Memory Address Bus	Output, 100k pull-up resistor; high-Z
57	35	55	P1.6	General Purpose I/O that can act as a "wake-up" input	I/O, 10k or 200k pull-up resistor; high-Z
58	36	56	GND	Ground	GND
59	36	56	GND	Ground	GND
60	37	57	VDD	Supply Voltage	PWR
61	37	57	VDD	Supply Voltage	PWR
62	-	58	A15	External Memory Address Bus	Output, 100k pull-up resistor; high-Z
63	38	59	P1.5	General Purpose I/O that can act as a "wake-up" input	I/O, 10k or 200k pull-up resistor; high-Z
64	-	60	A14	External Memory Address Bus	Output, 100k pull-up resistor; high-Z
65	39	61	P1.4	General Purpose I/O that can act as a "wake-up" input	I/O, 10k or 200k pull-up resistor; high-Z
66	-	62	A13	External Memory Address Bus	Output, 100k pull-up resistor; high-Z
67	40	63	P1.3	General Purpose I/O that can act as a "wake-up" input	I/O, 10k or 200k pull-up resistor; high-Z
68	-	64	A12	External Memory Address Bus	Output, 100k pull-up resistor; high-Z
69	41	65	P1.2	General Purpose I/O that can act as a "wake-up" input	I/O, 10k or 200k pull-up resistor; high-Z
70	42=NC	66	A11	External Memory Address Bus (NC for 64-lead LQFP)	Output, 100k pull-up resistor; high-Z
71	43	67	P1.1	General Purpose I/O that can act as a "wake-up" input	I/O, 10k or 200k pull-up resistor; high-Z
72	-	68	A10	External Memory Address Bus	Output, 100k pull-up resistor; high-Z
73	44	69	GND	Ground	GND
74	44	69	GND	Ground	GND
75	45	70	VDD	Supply Voltage	PWR
76	45	70	VDD	Supply Voltage	PWR
77	-	71	A9	External Memory Address Bus	Output, 100k pull-up resistor; high-Z
78	46	72	P1.0	General Purpose I/O that can act as a "wake-up" input	I/O, 10k or 200k pull-up resistor; high-Z
79	-	73	A8	External Memory Address Bus	Output, 100k pull-up resistor; high-Z
80	47=NC	74	A7	External Memory Address Bus (NC for 64-lead LQFP)	Output, 100k pull-up resistor; high-Z
81	48	75	P0.7	General Purpose I/O that can act as a "wake-up" input	I/O, 10k or 200k pull-up resistor; high-Z
-	49=NC	76	NC	Not connected	
82	50	77	P0.6	General Purpose I/O that can act as a "wake-up" input	I/O, 10k or 200k pull-up resistor; high-Z
83	-	78	A6	External Memory Address Bus (NC for 64-lead LQFP)	Output, 100k pull-up resistor; high-Z
-	51=NC	79	NC	Not connected	
84	52	80	P0.5	General Purpose I/O that can act as a "wake-up" input	I/O, 10k or 200k pull-up resistor; high-Z
85	-	81	A5	External Memory Address Bus	Output, 100k pull-up resistor; high-Z
-	-	82	NC	Not connected	
86	53	83	P0.4	General Purpose I/O that can act as a "wake-up" input	I/O, 10k or 200k pull-up resistor; high-Z
87	-	84	A4	External Memory Address Bus (NC for 64-lead LQFP)	Output, 100k pull-up resistor; high-Z
-	54=NC	85	NC	Not connected	
88	55	86	GND	Ground	GND
89	55	86	GND	Ground	GND
90	56	87	PWM0	Pulse Width Modulator Output 0	Output; 10k pull-up resistor; high-Z
91	57	88	PWM1	Pulse Width Modulator Output 1	Output; 10k pull-up resistor; high-Z
92	58	89	VDD	Supply Voltage	PWR
93	58	89	VDD	Supply Voltage	PWR
-	59=NC	90	NC	Not connected	
94	-	91	A3	External Memory Address Bus (NC for 64-lead LQFP)	Output, 100k pull-up resistor; high-Z

DIE Pad #	64 LQFP Pin #	100 LQFP Pin #	Pin Name	Description	Signal Type
95	60	92	P0.3	General Purpose I/O that can act as a "wake-up" input	I/O, 10k or 200k pull-up resistor; high-Z
-	-	93	NC	Not connected	
96	-	94	A2	External Memory Address Bus	Output, 100k pull-up resistor; high-Z
97	61	95	P0.2	General Purpose I/O that can act as a "wake-up" input	I/O, 10k or 200k pull-up resistor; high-Z
98	-	96	A1	External Memory Address Bus (NC for 64-lead LQFP)	Output, 100k pull-up resistor; high-Z
-	62=NC	97	NC	Not connected	
99	63	98	P0.1	General Purpose I/O that can act as a "wake-up" input	I/O, 10k or 200k pull-up resistor; high-Z
100	-	99	A0	External Memory Address Bus (NC for 64-lead LQFP)	Output, 100k pull-up resistor; high-Z
-	64=NC	100	NC	Not connected	

RSC-4128 Die Bonding Pad Locations

PAD #	PADNAME	X (um)	Y (um)	PAD #	PADNAME	X (um)	Y (um)	PAD #	PADNAME	X (um)	Y (um)	PAD #	PADNAME	X (um)	Y (um)
1	P0.0	95	4564	30	DACOUT	447	95	53	PLLEN	2965	368	82	P0.6	2694	4880
2	D7	95	4412	31	AVSS	542	95	54	A17	2965	516	83	A6	2599	4880
3	D6	95	4260	32	VCM	637	95	55	P1.7	2965	665	84	P0.5	2504	4880
4	PDN	95	4107	33	MICIN2	732	95	56	A16	2965	813	85	A5	2409	4880
5	D5	95	3955	34	MICIN1	827	95	57	P1.6	2965	961	86	P0.4	2314	4880
6	D4	95	3803	35	AMPCOM	922	95	58	GND	2965	1110	87	A4	2219	4880
7	GND	95	3651	36	VREF	1017	95	59	GND	2965	1291	88	GND	2124	4880
8	GND	95	3498	37	AVDD	1112	95	60	VDD	2965	1446	89	GND	2029	4880
9	XO1	95	3346	38	P2.4	1364	95	61	VDD	2965	1681	90	PWM0	1792	4880
10	XI1	95	3251	39	P2.3	1459	95	62	A15	2965	1831	91	PWM1	1366	4880
11	VDD	95	3063	40	P2.2	1554	95	63	P1.5	2965	1972	92	VDD	1128	4880
12	VDD	95	2858	41	GND	1649	95	64	A14	2965	2104	93	VDD	1033	4880
13	-XM	95	2729	42	P2.1	1744	95	65	P1.4	2965	2237	94	A3	938	4880
14	XO2	95	2605	43	P2.0	1839	95	66	A13	2965	2366	95	P0.3	843	4880
15	XI2	95	2510	44	GND	1934	95	67	P1.3	2965	2481	96	A2	748	4880
16	D3	95	2376	45	VDD	2029	95	68	A12	2965	2596	97	P0.2	653	4880
17	D2	95	2238	46	-RDF	2124	95	69	P1.2	2965	2708	98	A1	558	4880
18	P2.7	95	2095	47	-WRD	2219	95	70	A11	2965	2817	99	P0.1	463	4880
19	D1	95	1943	48	-RDR	2314	95	71	P1.1	2965	3061	100	A0	368	4880
20	D0	95	1790	49	-WRC	2409	95	72	A10	2965	3194				
21	GND	95	1667	50	A19	2504	95	73	GND	2965	3358				
22	GND	95	1434	51	A18	2599	95	74	GND	2965	3513				
23	VDD	95	1282	52	TEST	2694	95	75	VDD	2965	3678				
24	VDD	95	1129					76	VDD	2965	3827				
25	P2.6	95	964					77	A9	2965	3975				
26	reserved	95	825					78	P1.0	2965	4123				
27	P2.5	95	672					79	A8	2965	4272				
28	reserved	95	520					80	A7	2965	4420				
29	-RESET	95	368					81	P0.7	2965	4568				

Notes:

- Coordinates are in microns (um), rounded to nearest um.
- Coordinates are of the center of the bonding pad opening (70um).
- Coordinate (0,0) is the lower left corner of the die.
- Die size with scribe and seal ring is 3060 um x 4975 um.
- No external die substrate tie is required. However, a substrate tie to ground is preferred.**

Mechanical Data

LQFP 100 PLASTICQUAD FLATPACK (14x14x1.4 mm)

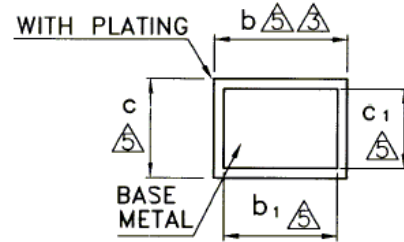
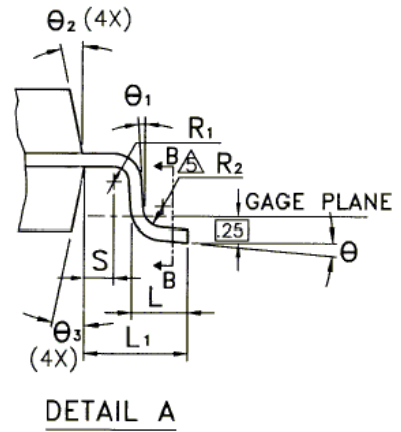
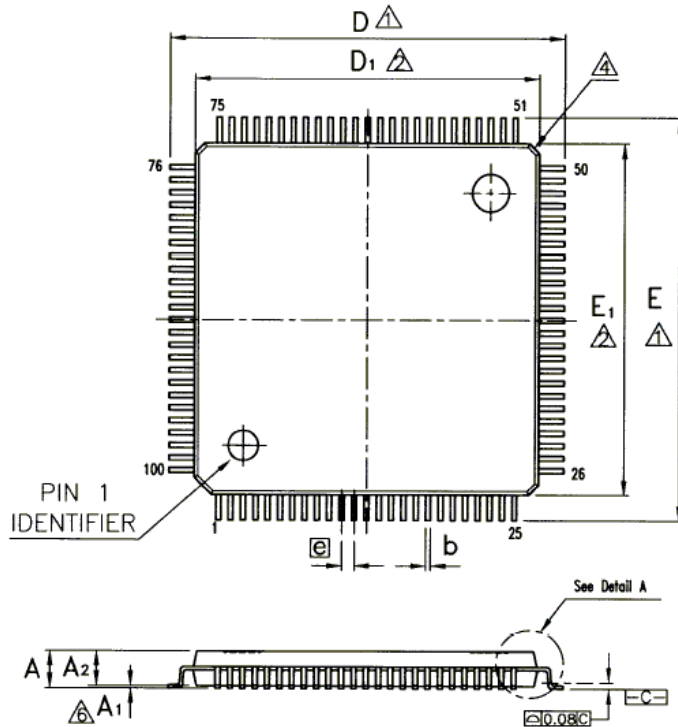

Symbol	Dimension in mm			Dimension in inch		
	Min	Nom	Max	Min	Nom	Max
A	-	-	1.60	-	-	0.063
A1	0.05	-	0.15	0.002	-	0.006
A2	1.35	1.40	1.45	0.053	0.055	0.057
b	0.17	0.22	0.27	0.007	0.009	0.011
b1	0.17	0.20	0.23	0.007	0.008	0.009
c	0.09	-	0.20	0.004	-	0.008
c1	0.09	-	0.16	0.004	-	0.006
D	15.85	16.00	16.15	0.624	0.630	0.636
D1	13.90	14.00	14.10	0.547	0.551	0.555
E	15.85	16.00	16.15	0.624	0.630	0.636
E1	13.90	14.00	14.10	0.547	0.551	0.555
$\text{\textcircled{C}}$	0.50 BSC			0.20 BSC		
L	0.45	0.60	0.75	0.018	0.024	0.030
L1	1.00 REF			0.039 BSC		
R1	0.08	-	-	0.003	-	-
R2	0.08	-	0.20	0.003	-	0.008
S	0.20	-	-	0.008	-	-
θ	0°	3.5°	7°	0°	3.5°	7°
θ_1	0°	-	-	0°	-	-
θ_2	12° TYP			12° TYP		
θ_3	12° TYP			12° TYP		

Notes:

- A. All linear dimensions are in millimeters.
- B. This drawing is subject to change without notice.
- C. Falls within JEDEC MS-026 BBC

LQFP 64 PLASTICQUAD FLATPACK (10x10x1.4 mm)

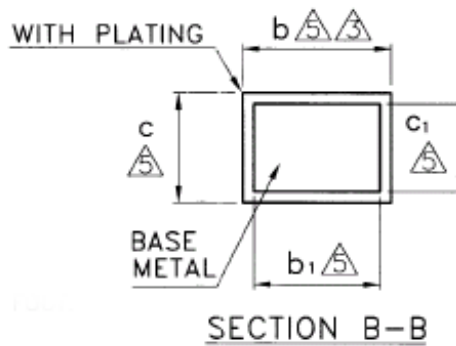
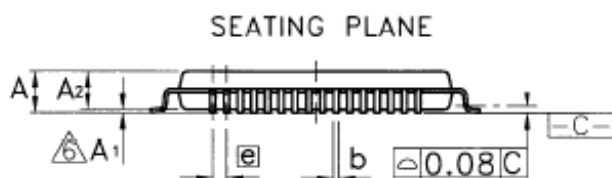
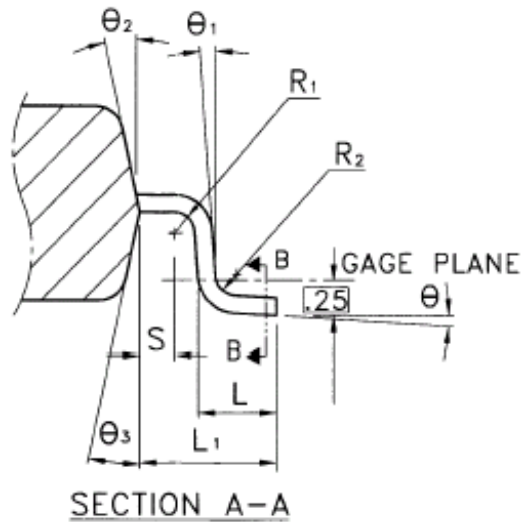
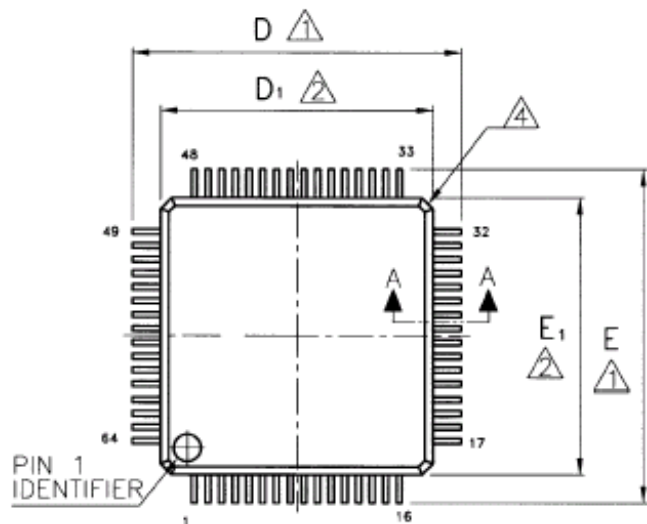

SECTION B-B

Symbol	Dimension in mm			Dimension in inch		
	Min	Nom	Max	Min	Nom	Max
A	-	-	1.60	-	-	0.063
A1	0.05	-	0.15	0.002	-	0.006
A2	1.35	1.40	1.45	0.053	0.055	0.057
b	0.17	0.22	0.27	0.007	0.009	0.011
b1	0.17	0.20	0.23	0.007	0.008	0.009
c	0.09	-	0.20	0.004	-	0.008
c1	0.09	-	0.16	0.004	-	0.006
D	12.00 BSC			0.472 BSC		
D1	10.00 BSC			0.394 BSC		
E	12.00 BSC			0.472 BSC		
E1	10.00 BSC			0.394 BSC		
e	0.50 BSC			0.20 BSC		
L	0.45	0.60	0.75	0.018	0.024	0.030
L1	1.00 REF			0.039 BSC		
R1	0.08	-	-	0.003	-	-
R2	0.08	-	0.20	0.003	-	0.008
S	0.20	-	-	0.008	-	-
theta	0°	3.5°	7°	0°	3.5°	7°
theta_1	0°	-	-	0°	-	-
theta_2	12° TYP			12° TYP		
theta_3	12° TYP			12° TYP		

Notes:
 D. All linear dimensions are in millimeters.
 E. This drawing is subject to change without notice.
 F. Falls within JEDEC MS-026, BBC

Ordering Information

Part	Shipping P/N	Description
RSC-4128 Die	(ROM specific)	Tested, Singulated RSC-4128 die in waffle pack
RSC-4128 64LQFP	(ROM specific)	RSC-4128 64 pin 10 x 10 x 1.4 mm LQFP
RSC-4128 100LQFP	(ROM specific)	RSC-4128 100 pin 14 x 14 x 1.4 mm LQFP

The Interactive Speech™ Product Line

The Interactive Speech line of ICs and software was developed to "bring life to products" through advanced speech recognition and audio technology. The Interactive Speech Product Line was designed for consumer telephony products and cost-sensitive consumer electronic applications such as home electronics, personal security, and personal communication. The product line includes award-winning RSC series general-purpose microcontrollers and tools, SC series of speech microcontrollers, plus a line of easy-to-implement chips that can be pin-configured or controlled by an external host microcontroller. Sensory's software technologies run on a variety of microcontrollers and DSPs.

RSC Microcontrollers and Tools

The RSC product line contains low-cost 8-bit speech-optimized microcontrollers designed for use in consumer electronics. All members of the RSC family are fully integrated and include A/D, pre-amplifier, D/A, ROM, and RAM circuitry. The RSC family can perform a full range of speech/audio functions including speech recognition, speaker verification, speech and music synthesis, and voice record/playback. The family is supported by a complete suite of evaluation tools and development kits.



SVC Microcontrollers and Tools

The SVC product line combines text-dependent speaker verification password biometrics with low-cost 8-bit microcontrollers designed for use in consumer electronics. All members of the SVC family are fully integrated for speech applications and include A/D, pre-amplifier, D/A, ROM, and RAM circuitry. The SVC family performs noise robust speaker verification password security functions and speech synthesis. The family is supported by a complete suite of evaluation tools and development kits.

SC Microcontrollers and Tools

The SC-6x product line feature the highest quality speech synthesis ICs at the lowest data rate in the industry. The line includes a 12.32 MIPS processor for high-quality low data-rate speech compression and MIDI music synthesis, with plenty of power left over for other processor and control functions. Members of the SC-6x line can store as much as 37 minutes of speech on chip and include as much as 64 I/O pins for external interfacing. Integrating this broad range of features onto a single chip enables developers to create products with high quality, long duration speech at very competitive price points.

Application Specific Standard Products (ASSPs)

Voice Direct™ II provides inexpensive speaker-dependent speech recognition and speech synthesis. This easy-to-use, pin-configurable chip requires no custom programming and can recognize up to 15 words in 4 pin-programmable modes. Ideal for speaker-dependent command and control of household consumer products, Voice Direct™ II is part of a complete product line that includes the IC, module, and Voice Direct™ II Speech Recognition Kit.



Voice Extreme™ simplifies the creation of fully custom speech-enabled products by offering developers the capability of programming the chip in a high-level C-like language. Program code, speech data, and even record and playback information can be stored on a single off-chip Flash memory. Based on Sensory's RSC-364 speech processor, Voice Extreme includes a highly efficient on-chip code interpreter, and is supported by a comprehensive suite of low-cost development tools.



Software and Technology

Voice Activation™ micro footprint software provides advanced speech technology on a variety of microcontroller and DSP platforms. A flexible design with a broad range of technologies allows manufacturers to easily integrate speech functionality into consumer electronic products.

Fluent Speech™ small footprint software recognizes up to 50,000 words; offers Animated Speech with the ability to automate enunciation and articulation; performs text-to-speech synthesis in either male or female voices; provides noise and echo cancellation, performs word spotting for natural language usage; offers telephone barge-in; and provides continuous digit recognition.



Important notices

Reasonable efforts have been made to verify the accuracy of information contained herein, however no guarantee can be made of accuracy or applicability. Sensory reserves the right to change any specification or description contained herein.



1991 Russell Ave., Santa Clara, CA 95054
Tel: (408) 327-9000 Fax: (408) 727-4748

© 2004 SENSORY, INC. ALL RIGHT RESERVED.
Sensory is registered by the U.S. Patent and Trademark Office.

All other trademarks or registered trademarks are the property of their respective owners.