

1. General Description

This ROM-Based 8-bit micro-controller uses a fully static CMOS design technology combines higher speed and smaller size with the low power and high noise immunity of CMOS.

On chip memory system includes 1.0 K bytes of ROM, and 32 bytes of static RAM.

2. Features

The followings are some of the features on the hardware and software :

- ◆ Fully CMOS static design
- ◆ 8-bit data bus
- ◆ On chip ROM size : 1,024 words
- ◆ Internal RAM size : 32 bytes
(25 general purpose registers, 7 special registers)
- ◆ 36 single word instructions
- ◆ 14-bit instructions
- ◆ 2-level stacks
- ◆ Operating voltage : 2.3V ~ 6.3 V
- ◆ Operating frequency : 0 ~ 20 MHz
- ◆ The most fast execution time is 200 ns under 20 MHz in all single cycle instructions except the branch instruction
- ◆ Addressing modes include direct, indirect and relative addressing modes
- ◆ Power-on Reset
- ◆ Power edge-detector Reset
- ◆ Sleep Mode for power saving
- ◆ 8-bit real time clock/counter(RTCC) with 8-bit programmable prescaler
- ◆ 4 types of oscillator can be selected by programming option:
RC - Low cost RC oscillator

LFXT - Low frequency crystal oscillator
XTAL - Standard crystal oscillator
HFXT - High frequency crystal oscillator

- ◆ 4 oscillator start-up time can be selected by programming option:
150 μ s, 20 ms, 40 ms, 80 ms
- ◆ On-chip RC oscillator based Watchdog Timer(WDT) can be operated freely
- ◆ Pull up resistors for the following pins :
PA0~PA3, PB0~PB7, /MCLR, RTCC
- ◆ Pull down resistors for the following pins :
PA0~PA3, PB0~PB7, RTCC
- ◆ 12 I/O pins with their own independent direction control

3. Applications

The application areas of this MDT1010 range from appliance motor control and high speed automotive to low power remote transmitters/receivers, pointing devices, and telecommunications processors, such as Remote controller, small instruments, chargers, toy, automobile and PC peripheral ... etc.

4. Pin Assignment

PA2	1	18	PA1
PA3	2	17	PA0
RTCC	3	16	OSC1
/MCLR	4	15	OSC2
V _{ss}	5	14	V _{dd}
PB0	6	13	PB7
PB1	7	12	PB6
PB2	8	11	PB5
PB3	9	10	PB4

5. Pin Function Description

Pin Name	I/O	Function Description
PA0~PA3	I/O	Port A, TTL input level
PB0~PB7	I/O	Port B, TTL input level
RTCC	I	Real Time Clock/Counter, Schmitt Trigger input levels
/MCLR	I	Master Clear, Schmitt Trigger input levels
OSC1	I	Oscillator Input
OSC2	O	Oscillator Output
V _{dd}		Power supply
V _{ss}		Ground

6. Memory Map

(A) Register Map

Address	Description
00	Indirect Addressing Register
01	RTCC
02	PC
03	STATUS
04	MSR
05	Port A
06	Port B
07~1F	Internal RAM, General Purpose Register

(1) IAR (Indirect Address Register) : R0

(2) RTCC (Real Time Counter/Counter Register) : R1

(3) PC (Program Counter) : R2

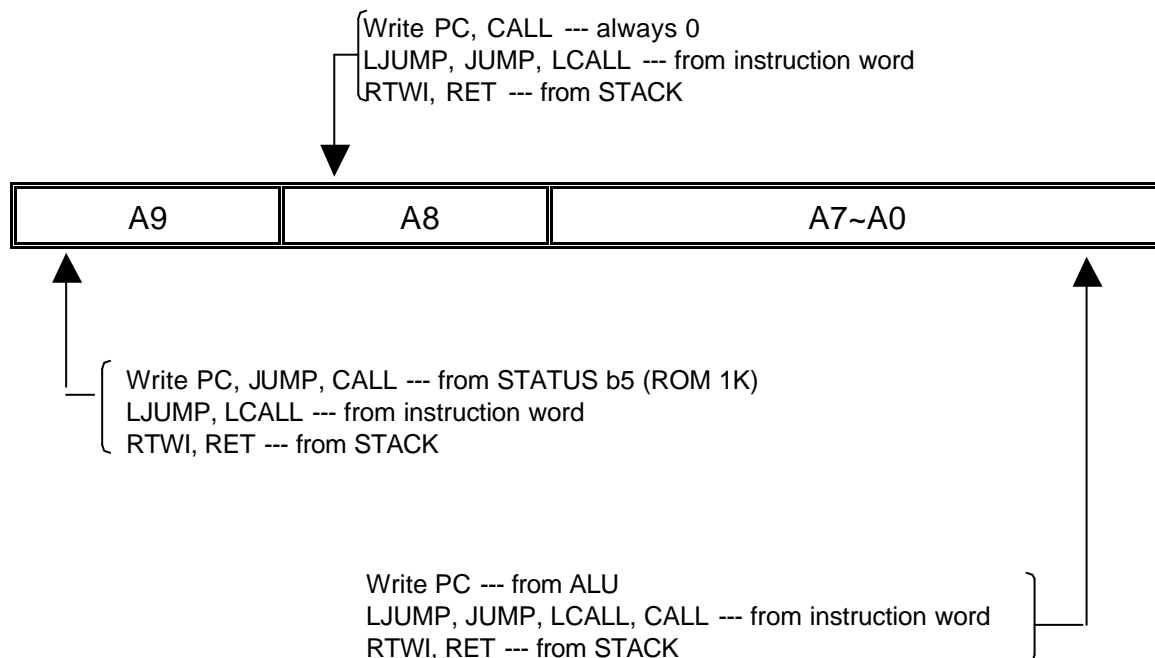

(4) STATUS (Status register) : R3

Bit	Symbol	Function
0	C	Carry bit
1	HC	Half Carry bit
2	Z	Zero bit
3	PF	Power loss Flag bit
4	TF	Time overflow Flag bit
5	page 0	Page select bit : 0 : 000H --- 1FFH 1 : 200H --- 3FFH
6—7	—	General purpose bit

(5) MSR (Memory Select Register) : R4

(6) PORT A : R5

PA3~PA0, I/O Register

(7) PORT B : R6

PB7~PB0, I/O Register

(8) TMR (Time Mode Register)

Bit	Symbol	Function		
		Prescaler Value	RTCC rate	WDT rate
2—0	PS2—0	0 0 0	1 : 2	1 : 1
		0 0 1	1 : 4	1 : 2
		0 1 0	1 : 8	1 : 4
		0 1 1	1 : 16	1 : 8
		1 0 0	1 : 32	1 : 16
		1 0 1	1 : 64	1 : 32
		1 1 0	1 : 128	1 : 64
		1 1 1	1 : 256	1 : 128
3	PSC	Prescaler assignment bit : 0 — RTCC 1 — Watchdog Timer		
4	TCE	RTCC signal Edge : 0 — Increment on low-to-high transition on RTCC pin 1 — Increment on high-to-low transition on RTCC pin		
5	TCS	RTCC signal set : 0 — Internal instruction cycle clock 1 — Transition on RTCC pin		

(9) CPIO A, CPIO B (Control Port I/O Mode Register)

The CPIO register is “write-only”

= “0”, I/O pin in output mode;

= “1”, I/O pin in input mode.

(10) Configuration ROM :

Bit 1	Bit 0	Oscillator Type
0	0	RC Oscillator
0	1	LFXT Oscillator
1	0	XTAL Oscillator
1	1	HFXT Oscillator

Bit 3	Bit 2	Oscillator Start-up Time
0	0	150 μ s
0	1	20 ms
1	0	40 ms
1	1	80 ms

Bit 4	Watchdog Timer control
0	Watchdog timer disable all the time
1	Watchdog timer enable all the time

Bit 5	Power Edge-detector
0	Disable
1	Enable

(B) Program Memory

Address	Description
000-3FF	Program memory
3FF	The starting address of the power on, external reset or WDT

7. Reset Condition for all Registers

Register	Address	Power-On Reset	/MCLR or WDT Reset
CPIO A	- -	1111 1111	1111 1111
CPIO B	- -	1111 1111	1111 1111
TMR	- -	--11 1111	--11 1111
IAR	00h	-	-
RTCC	01h	xxxx xxxx	uuuu uuuu
PC	02h	1111 1111	1111 1111
STATUS	03h	0001 1xxx	000# #uuu
MSR	04h	111x xxxx	111u uuuu
PORT A	05h	- - - - xxxx	- - - - uuuu
PORT B	06h	xxxx xxxx	uuuu uuuu

Note : u = unchanged, x = unknown, - = unimplemented, read as "0"

= value depends on the condition of the following table

Condition	Status: bit 4	Status: bit 3
/MCLR reset (not during SLEEP)	u	u
/MCLR reset during SLEEP	1	0
WDT reset (not during SLEEP)	0	1
WDT reset during SLEEP	0	0

8. Instruction Set

Instruction Code	Mnemonic Operands	Function	Operating	Status
010000 00000000	NOP	No operation	None	
010000 00000001	CLRWT	Clear Watchdog timer	0 WT	TF, PF
010000 00000010	SLEEP	Sleep mode	0 WT stop OSC	TF, PF
010000 00000011	TMODE	Load W to TMODE register	W TMODE	None
010000 00000100	RET	Return	Stack PC	None
010000 00000rrr	CPIO R	Control I/O port register	W CPIO r	None
010001 1rrrrrrr	STWR R	Store W to register	W R	None
011000 trrrrrrr	LDR R, t	Load register	R t	Z
111010 iiiiii	LDWI I	Load immediate to W	I W	None

This specification are subject to be changed without notice. Any latest information please preview

Instruction Code	Mnemonic Operands	Function	Operating	Status
010111 trrrrrrr	SWAPR R, t	Swap halves register	[R(0~3) ↔ R(4~7)] t	None
011001 trrrrrrr	INCR R, t	Increment register	R + 1 t	Z
011010 trrrrrrr	INCRSZ R, t	Increment register, skip if zero	R + 1 t	None
011011 trrrrrrr	ADDWR R, t	Add W and register	W + R t	C, HC, Z
011100 trrrrrrr	SUBWR R, t	Subtract W from register	R - W t (R+/W+1 t)	C, HC, Z
011101 trrrrrrr	DECR R, t	Decrement register	R - 1 t	Z
011110 trrrrrrr	DECRSZ R, t	Decrement register, skip if zero	R - 1 t	None
010010 trrrrrrr	ANDWR R, t	AND W and register	R W t	Z
110100 iiiiii	ANDWI i	AND W and immediate	i W W	Z
010011 trrrrrrr	IORWR R, t	Inclu. OR W and register	R W t	Z
110101 iiiiii	IORWI i	Inclu. OR W and immediate	i W W	Z
010100 trrrrrrr	XORWR R, t	Exclu. OR W and register	R W t	Z
110110 iiiiii	XORWI i	Exclu. OR W and immediate	i W W	Z
011111 trrrrrrr	COMR R, t	Complement register	/R t	Z
010110 trrrrrrr	RRR R, t	Rotate right register	R(n) R(n-1), C R(7), R(0) C	C
010101 trrrrrrr	RLR R, t	Rotate left register	R(n) r(n+1), C R(0), R(7) C	C
010000 1xxxxxxx	CLRW	Clear working register	0 W	Z
010001 0rrrrrrr	CLRR R	Clear register	0 R	Z
0000bb brrrrrrr	BCR R, b	Bit clear	0 R(b)	None
0010bb brrrrrrr	BSR R, b	Bit set	1 R(b)	None
0001bb brrrrrrr	BTSC R, b	Bit Test, skip if clear	Skip if R(b)=0	None
0011bb brrrrrrr	BTSS R, b	Bit Test, skip if set	Skip if R(b)=1	None
1000nn nnnnnnnn	LCALL n	Long CALL subroutine	n PC, PC+1 Stack	None
1010nn nnnnnnnn	LJUMP n	Long JUMP to address	n PC	None
110000 nnnnnnnn	CALL n	Call subroutine	n PC, PC+1 Stack	None
110001 iiiiii	RTWI i	Return, place immediate to W	Stack PC, i W	None
11001n nnnnnnnn	JUMP n	JUMP to address	n PC	None

Note :

W	: Working register	b	: Bit position
WT	: Watchdog timer	t	: Target
TMODE	: TMODE mode register	0	: Working register
CPIO	: Control I/O port register	1	: General register
TF	: Timer overflow flag	R	: General register address
PF	: Power loss flag	C	: Carry flag
PC	: Program Counter	HC	: Half carry
OSC	: Oscillator	Z	: Zero flag
Inclu.	: Inclusive ' '	/	: Complement
Exclu.	: Exclusive ' '	x	: Don' t care
AND	: Logic AND ' '	i	: Immediate data (8 bits)
		n	: Immediate address

9. Electrical Characteristics

(A) Operating Voltage & Frequency

V_{dd} : 2.3 V ~ 6.3 V

Frequency : 0 Hz ~ 20 MHz

(B) Input Voltage

@ $V_{dd} = 5.0$ V, Temperature = 25

	Port	Min.	Max.
V_{il}	PA, PB	V_{ss}	1.0 V
	RTCC, /MCLR	V_{ss}	0.8 V
V_{ih}	PA, PB	2.0 V	V_{dd}
	RTCC, /MCLR	3.5 V	V_{dd}

* Threshold Voltage :

Port A, Port B $V_{th} = 1.54$ V

RTCC, /MCLR $V_{il} = 1.35$ V, $V_{ih} = 2.85$ V (Schmitt Trigger)

(C) Output Voltage :

@ $V_{dd} = 5.0\text{ V}$, Temperature = 25 , the typical value as followings :

PA, PB Port	
$I_{oh} = -20.0\text{ mA}$	$V_{oh} = 3.50\text{ V}$
$I_{ol} = 20.0\text{ mA}$	$V_{ol} = 0.60\text{ V}$
$I_{oh} = -5.0\text{ mA}$	$V_{oh} = 4.60\text{ V}$
$I_{ol} = 5.0\text{ mA}$	$V_{ol} = 0.25\text{ V}$

(D) Leakage Current

@ $V_{dd} = 5.0\text{ V}$, Temperature = 25 , the typical value as followings :

I_{il}	- 1.0 μA (Max.)
I_{ih}	+ 1.0 μA (Max.)

(E) Sleep Current

@**WDT - Disable**, Temperature = 25 , the typical value as followings :

$$V_{dd} = 2.3\text{ V} \sim 6.3\text{V} \quad I_{dd} < 1.0\mu\text{A}$$

@**WDT - Enable**, Temperature = 25 , the typical value as followings :

$V_{dd} = 2.3\text{ V}$	$I_{dd} < 1.0\ \mu\text{A}$
$V_{dd} = 3.0\text{ V}$	$I_{dd} = 1.2\ \mu\text{A}$
$V_{dd} = 4.0\text{ V}$	$I_{dd} = 4.0\ \mu\text{A}$
$V_{dd} = 5.0\text{ V}$	$I_{dd} = 12.0\ \mu\text{A}$
$V_{dd} = 6.3\text{ V}$	$I_{dd} = 20.0\ \mu\text{A}$

(F) Operation Current

Temperature = 25 , the typical value as followings :

(i) OSC Type = RC ; WDT - Enable; @ $V_{dd} = 5.0\text{ V}$

Cext. (F)	Rext. (Ohm)	Frequency (Hz)	Current (A)
3P	4.7 K	10.26 M	1.35 m
	10.0 K	6.00 M	790.0 μ
	47.0 K	1.476 M	230.0 μ
	100.0 K	724.4 K	135.0 μ
	300.0 K	242.4 K	70.0 μ
	470.0 K	151.6 K	60.0 μ
20P	4.7 K	5.12 M	680.0 μ
	10.0 K	2.774 M	390.0 μ
	47.0 K	640.0 K	125.0 μ
	100.0 K	307.6 K	78.0 μ
	300.0 K	101.2K	55.0 μ
	470.0 K	63.68 K	50.0 μ
100P	4.7 K	1.53 M	240.0 μ
	10.0 K	781.2 K	140.0 μ
	47.0 K	172.4.0K	65.0 μ
	100.0 K	82.0 K	50.0 μ
	300.0 K	27.0 K	47.0 μ
	470.0 K	17.0 K	45.0 μ
300P	4.7 K	633.6 K	125.0 μ
	10.0 K	322.4 K	85.0 μ
	47.0 K	69.60 K	55.0 μ
	100.0 K	33.04 K	50.0 μ
	300.0 K	10.8 K	45.0 μ
	470.0 K	6.84 K	43.0 μ

(ii) OSC Type = LF (C=20 p); WDT - Disable; PED-Disable

Voltage/Frequency	32 K	455 K	1 M	Sleep
2.3 V	4.0 μA	X	X	< 1.0 μA
3.0 V	6.0 μA	50.0 μA	80.0 μA	< 1.0 μA
4.0 V	15.0 μA	70.0 μA	125.0 μA	< 1.0 μA
5.0 V	30.0 μA	120.0 μA	200.0 μA	< 1.0 μA
6.3 V	40.0 μA	180.0 μA	250.0 μA	< 1.0 μA

(iii) OSC Type = XT (C=10 p); WDT - Enable; PED-Disable

Voltage/Frequency	1 M	4 M	10 M	Sleep
2.1 V	65.0 μ A	210.0 μ A	480.0 μ A	< 1.0 μ A
3.0 V	130.0 μ A	360.0 μ A	760.0 μ A	1.2 μ A
4.0 V	220.0 μ A	620.0 μ A	1.25 mA	4.0 μ A
5.0 V	330.0 μ A	980.0 μ A	1.80 mA	12.0 μ A
6.3 V	530.0 μ A	1.7 mA	2.70 mA	20.0 μ A

(iv) OSC Type = HF (C=10 p); WDT - Enable; PED-Disable

Voltage/Frequency	4 M	10 M	20 M	Sleep
2.1 V	190.0 μ A	420.0 μ A	@2.3v900.0 μ A	< 0.1 μ A
3.0 V	350.0 μ A	740.0 μ A	1.40 mA	1.2 μ A
4.0 V	670.0 μ A	1.3 mA	2.2 mA	4.0 μ A
5.0 V	1.1 mA	2.0 mA	3.2 mA	12.0 μ A
6.3 V	1.9 mA	3.0 mA	4.7 mA	20.0 μ A

(G) Pull Resistance

@ Input Mode : $V_{dd} = 3.0$ V

PORT	Pull-High Resistance	$R_{hi} = 300.0$ KOhm
	Pull-Low Resistance	$R_{lo} = 300.0$ KOhm
RTCC	Pull-High Resistance	$R_{hi} = 280.0$ KOhm
	Pull-Low Resistance	$R_{lo} = 280.0$ KOhm
/MCLR	Pull-High Resistance	$R_{hi} = 150.0$ KOhm

@ Input Mode : $V_{dd} = 5.0$ V

PORT	Pull-High Resistance	$R_{hi} = 100.0$ KOhm
	Pull-Low Resistance	$R_{lo} = 100.0$ KOhm
RTCC	Pull-High Resistance	$R_{hi} = 110.0$ KOhm
	Pull-Low Resistance	$R_{lo} = 110.0$ KOhm
/MCLR	Pull-High Resistance	$R_{hi} = 100.0$ KOhm

p.s. : It is only a reference value for the Pull High/Low Resistance, and the accurate

This specification are subject to be changed without notice. Any latest information please preview

value of the Resistance depends on the various parameter of the Process. But the variation of the value will be not more than 20%.

(H) Power Edge-detector Reset Voltage (Not in Sleep Mode), @ $V_{dd} = 5.0\text{ V}$

$V_{pr} \quad 1.1\sim 1.3\text{ V} \quad V_{pr} : V_{dd} \text{ (Power Supply)}$

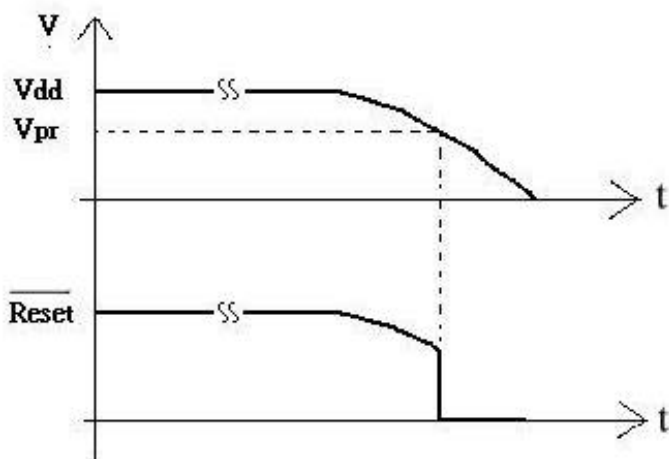

(I) The basic WDT time-out cycle time

Temperature = 25 , the typical value as followings :

Voltage (V)	Basic WDT time-out cycle time (ms)
2.3	34.00
3.0	27.60
4.0	23.20
5.0	20.40
6.3	18.00

(J) MCLRB Filter : @ $V_{dd}=5.0\text{v}$

$W_m \geq 1.2\mu\text{s}$ W_m : Filter pulse width (low) in /MCLR pin.

10. Port A and Port B Equivalent Circuit

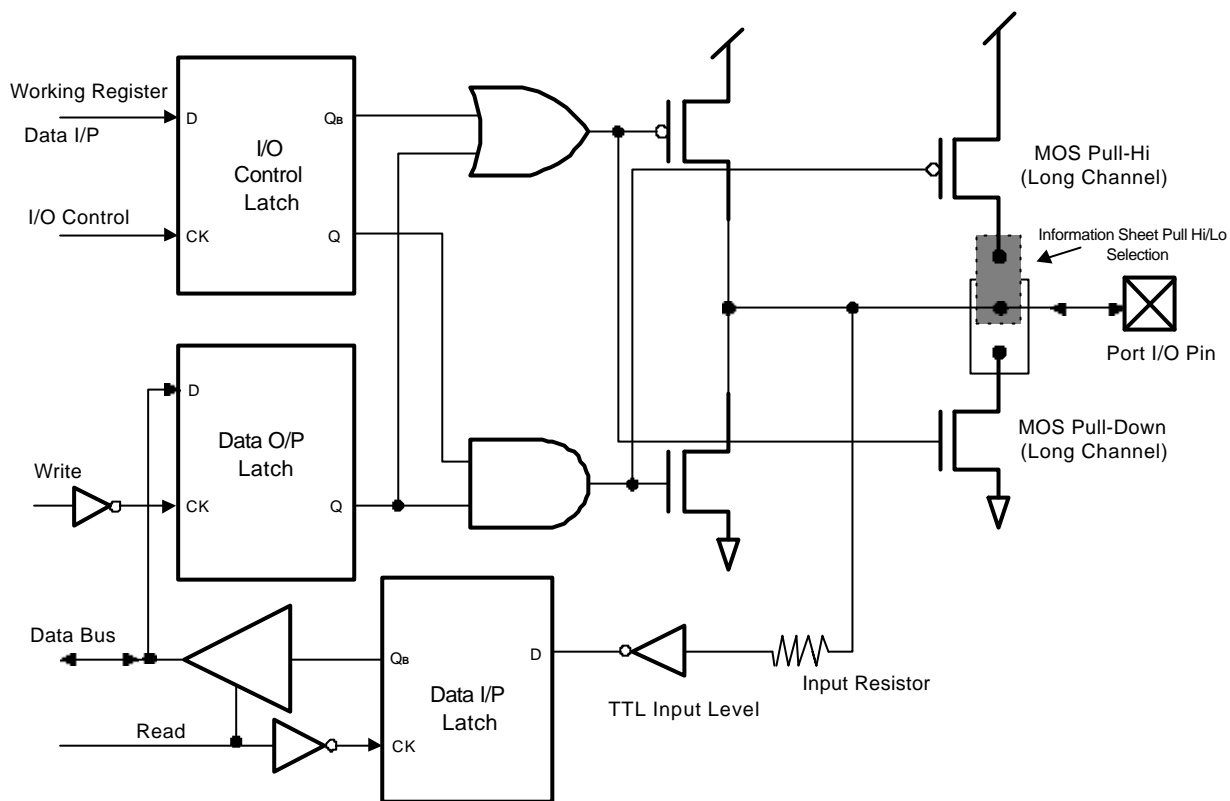

11. MCLRB and RTCC Input Equivalent Circuit

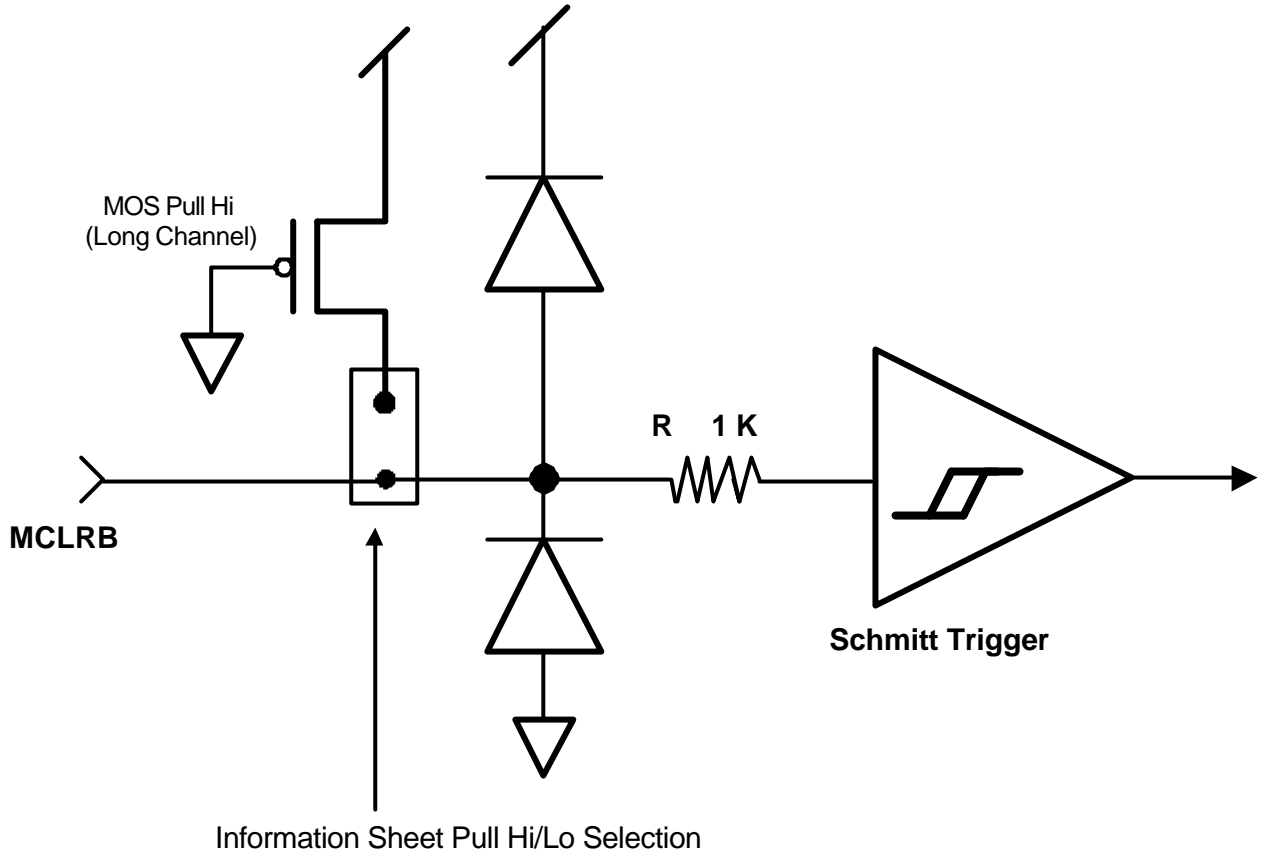

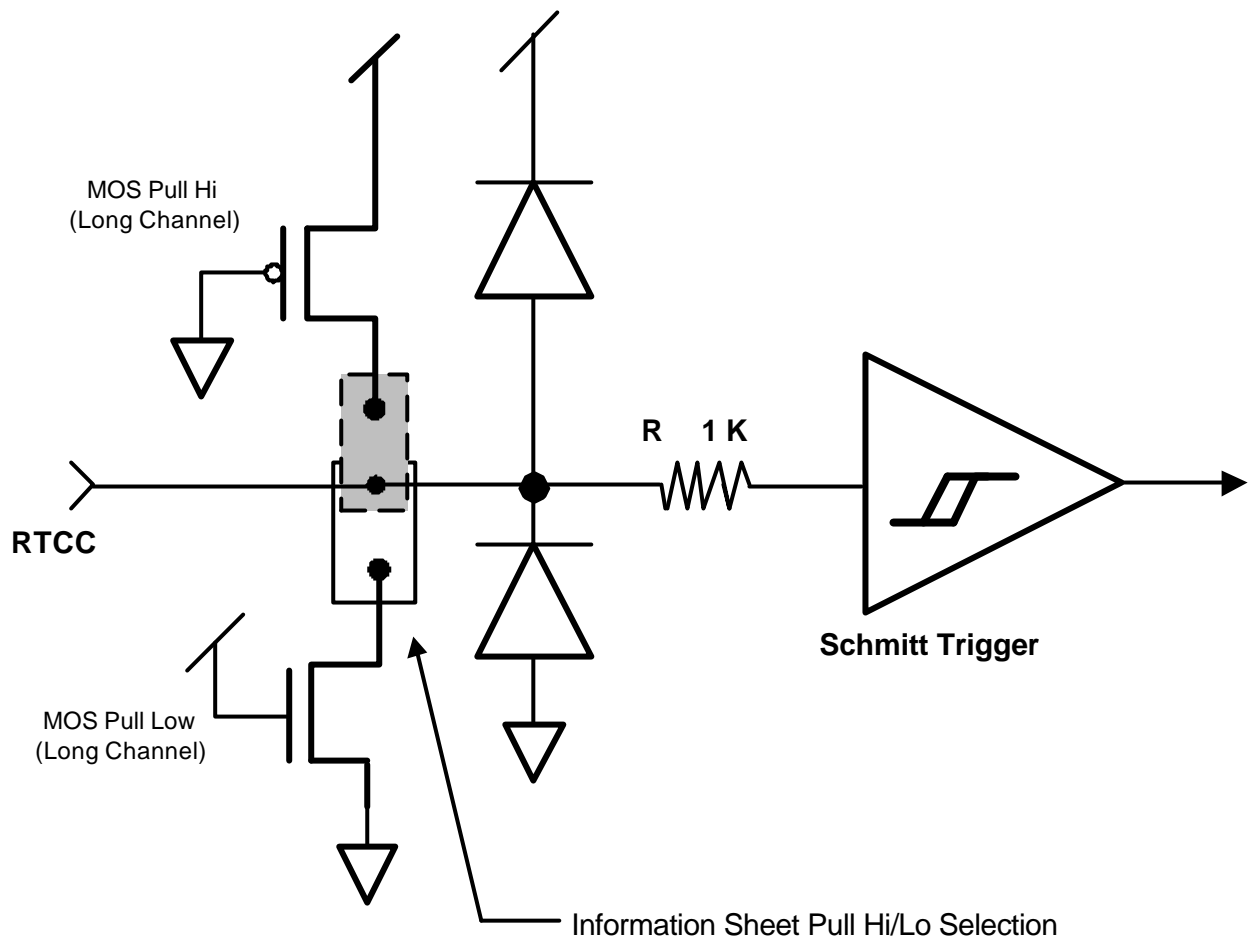

12. Block Diagram

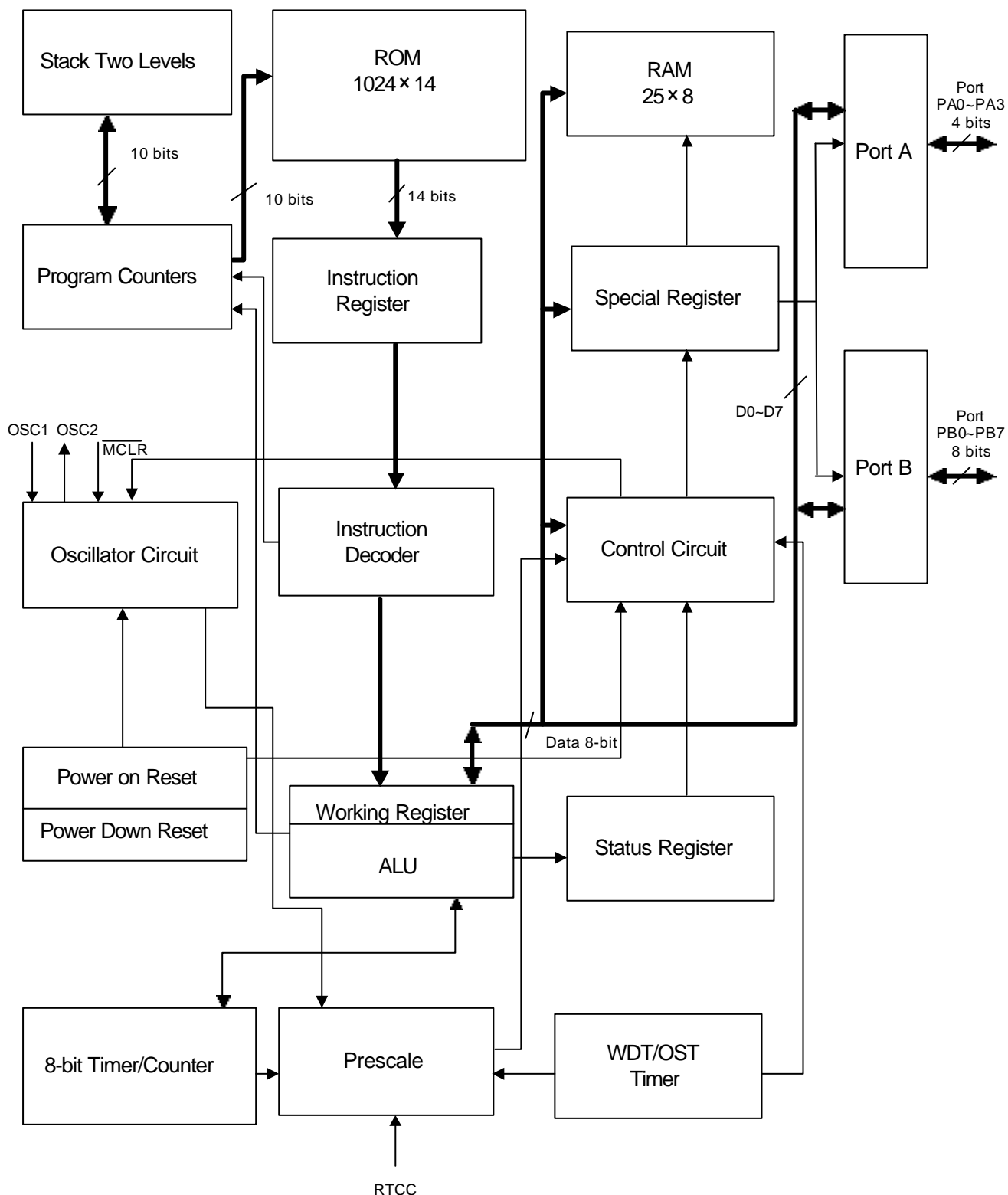

13. Capacitor Selection For Crystal Oscillator

(a) With built-in Oscillation Capacitors (Default for HF,XT,LF)

@ $V_{dd} = 2.3V \sim 5.5 V$, $C1=C2=10P \sim 15P$

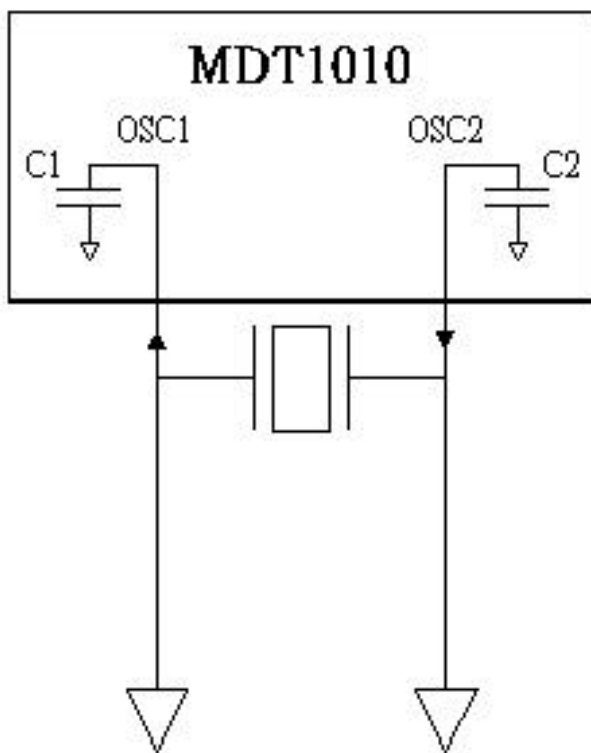

(b) Without built-in Oscillation Capacitors

@ $V_{dd} = 3.0\text{ V} \sim 5.0\text{ V}$

Osc. Type	Resonator Freq.	C1	C2
HF	20 MHz	5 pF ~10 pF	10 pF~30 pF
	10 MHz	10 pF ~50 pF	20 pF ~100 pF
	4 MHz	10 pF ~50 pF	20 pF ~100 pF
XT	10 MHz	10 pF ~30 pF	10 pF ~50 pF
	4 MHz	10 pF ~50 pF	20 pF ~100 pF
	1 MHz	10 pF ~30 pF	20 pF ~50 pF
LF	1 MHz	3 pF ~5 pF	3 pF ~5 pF
	455 K	10 pF ~30 pF	20 pF ~50 pF
	32 K	10 pF ~20 pF	15 pF ~30 pF

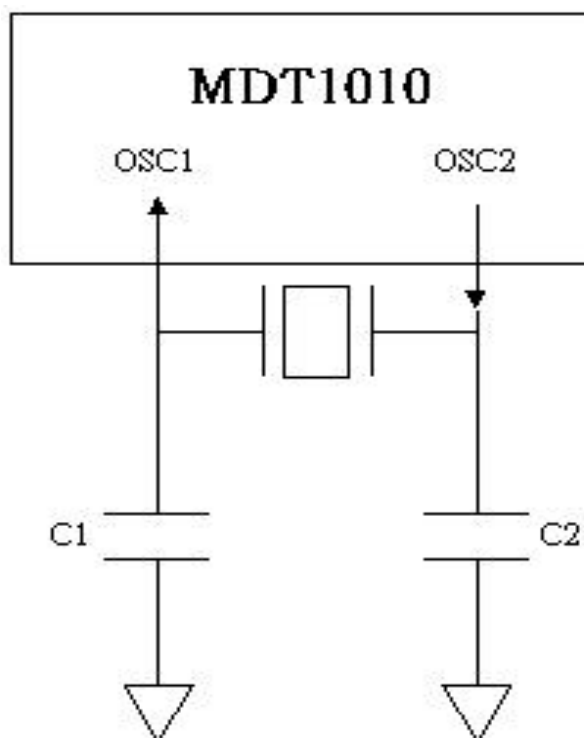

To increase the stability of oscillator and the ability of anti-noise, the above values of the external capacitor range are recommended, but the higher capacitance will increase the start-up time.
There do not have built-in Oscillation Capacitors for RC type.

