3SK295

Silicon N-Channel Dual Gate MOS FET

HITACHI

ADE-208-387
1st. Edition

Application

UHF RF amplifier

Features

- Low noise figure.
NF = 2.0 dB typ. at f = 900 MHz
- Capable of low voltage operation

Outline

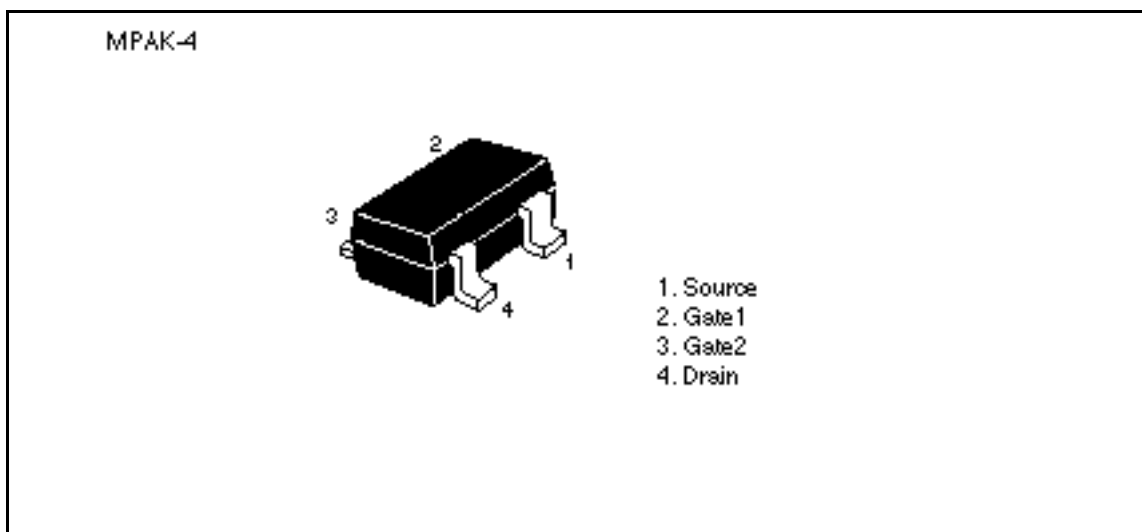

3SK295

Absolute Maximum Ratings (Ta = 25°C)

Item	Symbol	Ratings	Unit
Drain to source voltage	V_{DS}	12	V
Gate 1 to source voltage	V_{G1S}	±8	V
Gate 2 to source voltage	V_{G2S}	±8	V
Drain current	I_D	25	mA
Channel power dissipation	Pch	150	mW
Channel temperature	Tch	150	°C
Storage temperature	Tstg	-55 to +150	°C

Attention: This device is very sensitive to electro static discharge.

It is recommended to adopt appropriate cautions when handling this transistor.

Electrical Characteristics (Ta = 25°C)

Item	Symbol	Min	Typ	Max	Unit	Test conditions
Drain to source breakdown voltage	$V_{(BR)DSX}$	12	—	—	V	$I_D = 200 \mu A$, $V_{G1S} = -3 V$, $V_{G2S} = -3 V$
Gate 1 to source breakdown voltage	$V_{(BR)G1SS}$	±8	—	—	V	$I_{G1} = \pm 10 \mu A$, $V_{G2S} = V_{DS} = 0$
Gate 2 to source breakdown voltage	$V_{(BR)G2SS}$	±8	—	—	V	$I_{G2} = \pm 10 \mu A$, $V_{G1S} = V_{DS} = 0$
Gate 1 cutoff current	I_{G1SS}	—	—	±100	nA	$V_{G1S} = \pm 6 V$, $V_{G2S} = V_{DS} = 0$
Gate 2 cutoff current	I_{G2SS}	—	—	±100	nA	$V_{G2S} = \pm 6 V$, $V_{G1S} = V_{DS} = 0$
Drain current	$I_{DS(on)}$	0.5	—	10	mA	$V_{DS} = 6 V$, $V_{G1S} = 0.5V$, $V_{G2S} = 3 V$
Gate 1 to source cutoff voltage	$V_{G1S(off)}$	-0.5	—	+0.5	V	$V_{DS} = 10 V$, $V_{G2S} = 3V$, $I_D = 100 \mu A$
Gate 2 to source cutoff voltage	$V_{G2S(off)}$	0	—	+1.0	V	$V_{DS} = 10 V$, $V_{G1S} = 3V$, $I_D = 100 \mu A$
Forward transfer admittance	$ y_{fs} $	16	20.8	—	mS	$V_{DS} = 6 V$, $V_{G2S} = 3V$, $I_D = 10 mA$, $f = 1 kHz$
Input capacitance	Ciss	1.2	1.5	2.2	pF	$V_{DS} = 6 V$, $V_{G2S} = 3V$, $I_D = 10 mA$, $f = 1 MHz$
Output capacitance	Coss	0.6	0.9	1.2	pF	
Reverse transfer capacitance	Crss	—	0.01	0.03	pF	
Power gain	PG	16	19.5	—	dB	$V_{DS} = 4 V$, $V_{G2S} = 3V$, $I_D = 10 mA$, $f = 900 MHz$
Noise figure	NF	—	2.0	3	dB	

Note: Marking is "ZQ—"

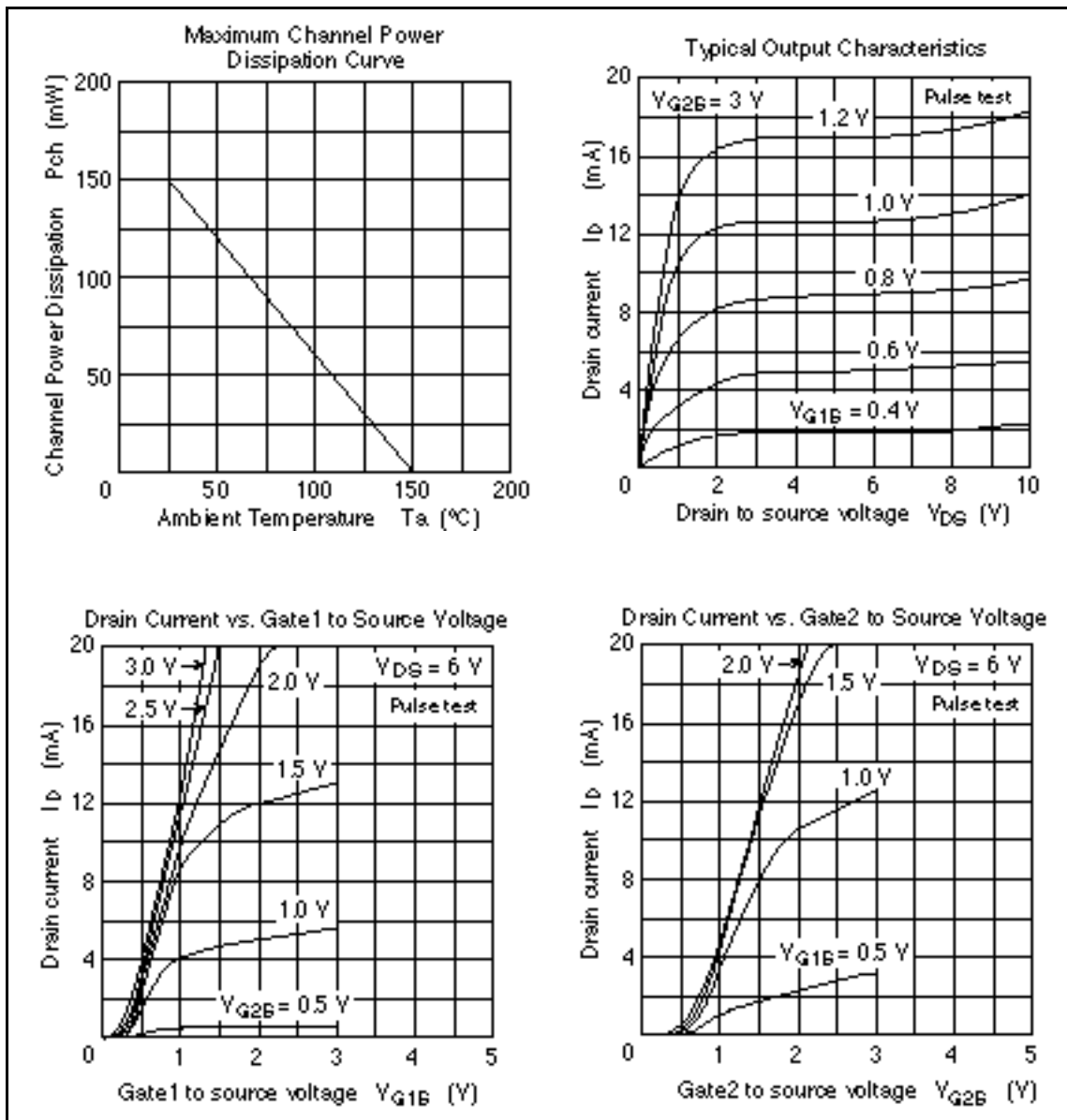

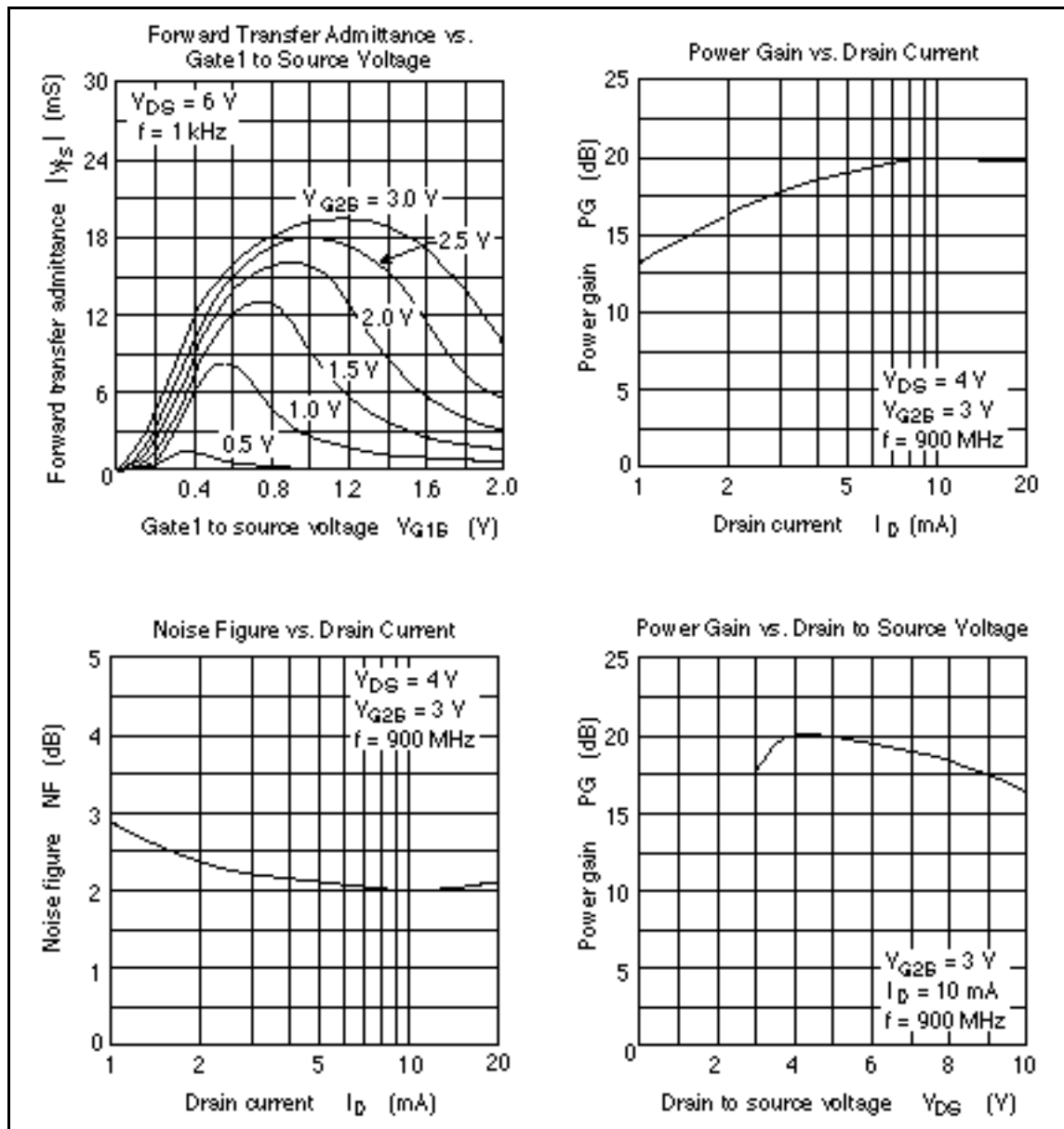

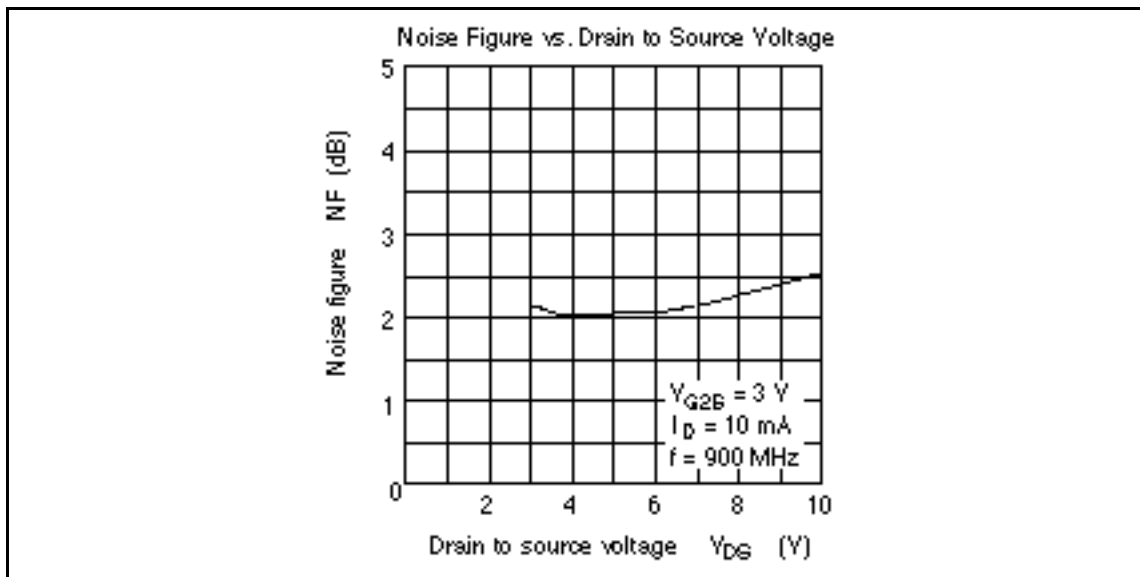

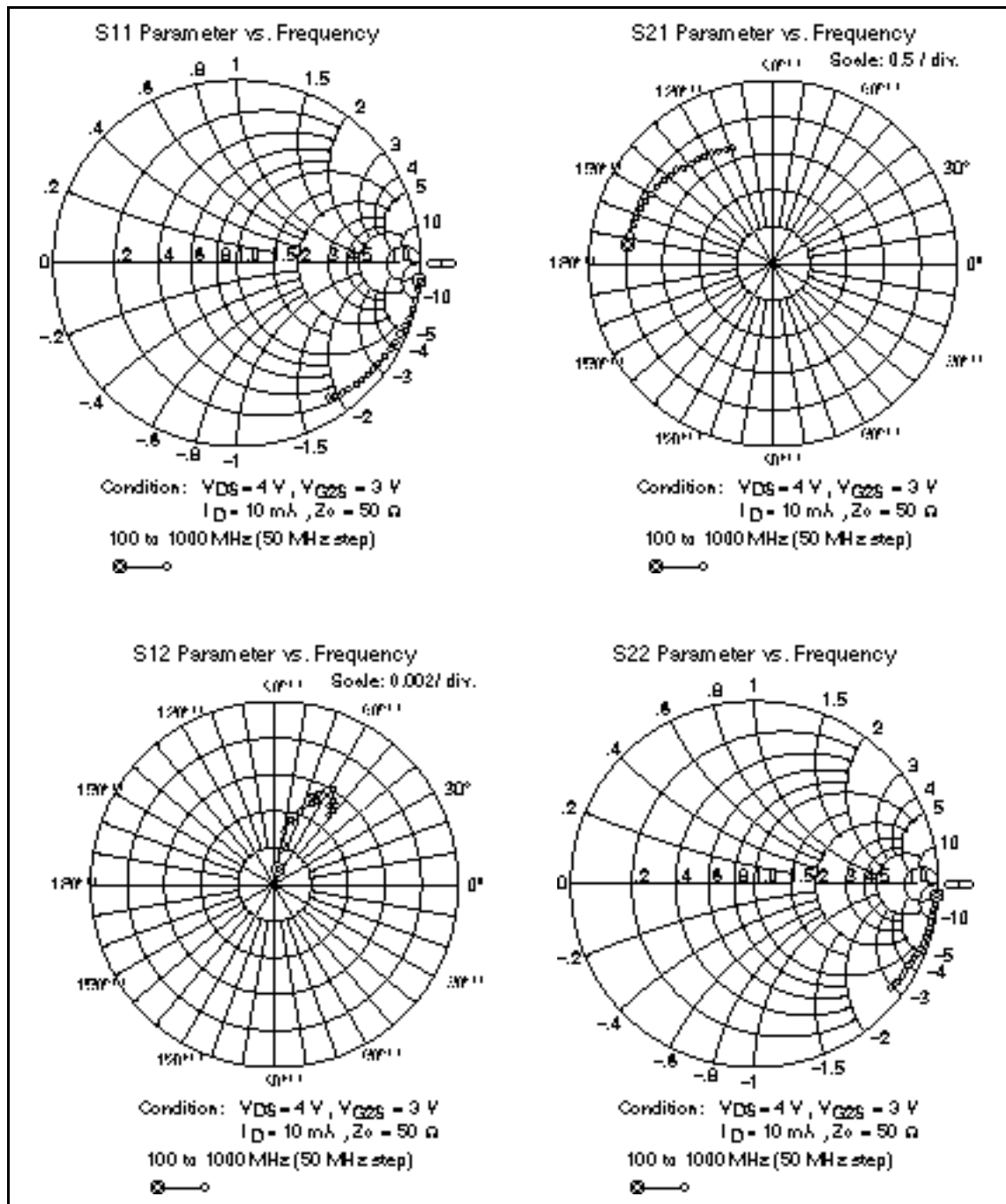

S Parameter ($V_{DS} = 4 \text{ V}$, $V_{G2S} = 3 \text{ V}$, $I_D = 10 \text{ mA}$, $Z_0 = 50 \text{ } \Omega$)

Freq. (MHz)	S11		S21		S12		S22	
	MAG.	ANG.	MAG.	ANG.	MAG.	ANG.	MAG.	ANG.
100	0.999	-6.1	1.98	172.2	0.00094	79.2	0.989	-4.2
150	0.998	-9.1	1.97	168.4	0.00189	80.4	0.987	-6.1
200	0.992	-11.9	1.96	165.0	0.00230	79.5	0.986	-7.9
250	0.988	-14.8	1.96	161.0	0.00286	79.9	0.984	-9.8
300	0.985	-17.9	1.94	157.1	0.00364	75.2	0.981	-11.5
350	0.976	-20.6	1.92	153.7	0.00353	71.8	0.978	-13.4
400	0.971	-23.2	1.91	149.9	0.00419	70.7	0.975	-15.2
450	0.964	-26.3	1.88	146.8	0.00495	65.5	0.972	-17.2
500	0.961	-29.1	1.87	142.8	0.00509	62.7	0.968	-19.1
550	0.951	-32.2	1.86	139.4	0.00530	66.6	0.963	-20.8
600	0.949	-35.0	1.86	136.1	0.00550	63.8	0.960	-22.8
650	0.935	-37.6	1.81	132.9	0.00601	58.2	0.956	-24.5
700	0.933	-40.5	1.78	129.4	0.00582	60.6	0.950	-26.3
750	0.923	-42.9	1.77	125.7	0.00572	58.5	0.945	-28.0
800	0.916	-45.8	1.75	122.6	0.00553	56.3	0.941	-29.9
850	0.908	-49.0	1.72	119.1	0.00514	56.3	0.936	-31.7
900	0.900	-51.2	1.70	115.8	0.00543	52.9	0.930	-33.4
950	0.890	-54.0	1.67	112.6	0.00506	52.4	0.924	-35.2
1000	0.876	-56.4	1.65	109.3	0.00469	51.9	0.919	-37.0

When using this document, keep the following in mind:

1. This document may, wholly or partially, be subject to change without notice.
2. All rights are reserved: No one is permitted to reproduce or duplicate, in any form, the whole or part of this document without Hitachi's permission.
3. Hitachi will not be held responsible for any damage to the user that may result from accidents or any other reasons during operation of the user's unit according to this document.
4. Circuitry and other examples described herein are meant merely to indicate the characteristics and performance of Hitachi's semiconductor products. Hitachi assumes no responsibility for any intellectual property claims or other problems that may result from applications based on the examples described herein.
5. No license is granted by implication or otherwise under any patents or other rights of any third party or Hitachi, Ltd.
6. **MEDICAL APPLICATIONS:** Hitachi's products are not authorized for use in **MEDICAL APPLICATIONS** without the written consent of the appropriate officer of Hitachi's sales company. Such use includes, but is not limited to, use in life support systems. Buyers of Hitachi's products are requested to notify the relevant Hitachi sales offices when planning to use the products in **MEDICAL APPLICATIONS**.

HITACHI

Hitachi, Ltd.

Semiconductor & IC Div.

Nippon Bldg., 2-5-2, Ohite-machi, Chiyoda-ku, Tokyo 100, Japan

Tel Tokyo (03) 3270-2111

Fax (03) 3270-5109

For further information write to:

Hitachi America, Ltd.

Semiconductor & IC Div.

2000 Sierra Point Parkway

Folsom, CA 94005-4835

U.S.A.

Tel 415-589-8300

Fax 415-589-4207

Hitachi Europe GmbH

Electronic Components Group

Continental Europe

Darnecker Straße 3

D-85622 Feldkirchen

München

Tel 089-9 91 80-0

Fax 089-9 29 30 00

Hitachi Europe Ltd.

Electronic Components Div.

Northern Europe Headquarters

Whitebrook Park

Lower Cookham Road

High Wycombe

Berkshire SL6 8YA

United Kingdom

Tel 0628-885000

Fax 0628-778322

Hitachi Asia Pte. Ltd.

45 Collyer Quay #20-00

Hitachi Tower

Singapore 0104

Tel 535-2100

Fax 535-1533

Hitachi Asia (Hong Kong) Ltd.

Unit 705, North Tower,

World Finance Centre

Harbour City, Canton Road

Tsim Sha Tsui, Kowloon

Hong Kong

Tel 27359218

Fax 27308074