

**SIEMENS**

**SFH 487P**

**GaAlAs INFRARED EMITTER**

T-41-13

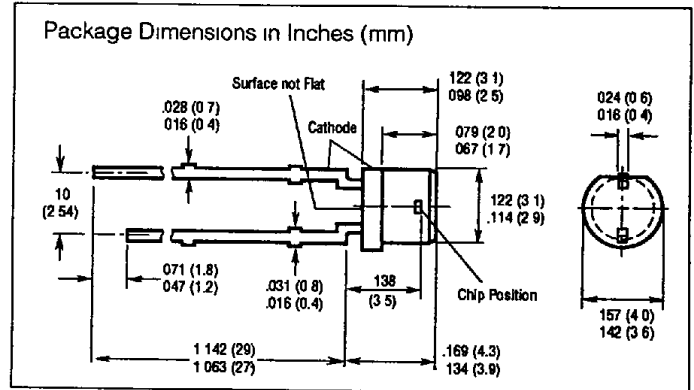
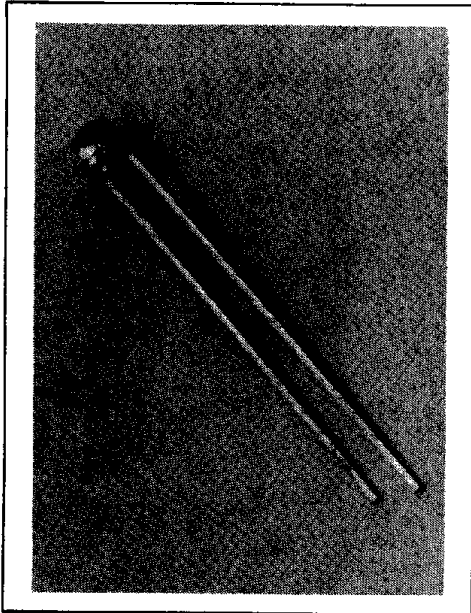

**FEATURES**

- Radiant Intensity Selections  
SFH487P-1 2-4  
SFH487P-2 ≥3.15
- Perfect Spectral Match with Silicon Photo Detector
- Gallium Aluminum Arsenide Material
- Low Cost
- T1 Package
- Flat Plastic Lens
- Long-Term Stability
- Very Wide Beam, 130°
- Very High Power, 20 mW Typical at 100 mA

**DESCRIPTION**

SFH 487P, an infrared emitting diode, emits radiation in the near infrared range (880 nm peak). The emitted radiation, which can be modulated, is generated by forward flowing current. The device is enclosed in a 3 mm diameter plastic package with a flat lens. Typical applications are in digital shaft encoders and light interruptors for DC and AC operation.

**Maximum Ratings**

Storage temperature	$T_{stg}$	-55 to +100	°C
Soldering temperature at dip soldering (≥ 2 mm distance from the case bottom, soldering time $t \leq 5$ sec)	$T_{sold}$	260	°C
Soldering temperature at iron soldering (≥ 2 mm distance from the case bottom, soldering time $t \leq 3$ sec)	$T_{sold}$	300	°C
Junction temperature	$T_j$	100	°C
Reverse voltage	$V_R$	5	V
Forward current	$I_F$	100	mA
Surge current ( $\tau = 10 \mu s$ )	$I_{FS}$	2.5	A
Power dissipation ( $T = 25^\circ C$ )	$P_{tot}$	200	mW
Thermal resistance*	$R_{thA}$	375	K/W

**Characteristics ( $T_{amb} = 25^\circ C$ )**

Wavelength at peak emission at $I_F = 10$ mA	$\lambda_{peak}$	880	nm
Wavelength at peak emission at $I_F = 100$ mA, $t_{pulse} = 20$ ms, Duty cycle = 1/12	$\lambda_{peak}$	883	nm
Wavelength at peak emission at $I_F = 1$ A, $t_{pulse} = 100 \mu s$ , Duty cycle = 1/100	$\lambda_{peak}$	886	nm
Spectral bandwidth at $I_F = 10$ mA	$\Delta\lambda$	80	nm
Half angle	$\varphi$	± 65	Deg
Active chip area	A	0.16	mm <sup>2</sup>
Dimensions of active chip area	L x W	0.4 x 0.4	mm
Distance chip surface to case surface	D	0.4 to 0.7	mm
Switching time ( $I_e$ from 10% to 90%, and from 90% to 10% $I_F \leq 100$ mA)	$t_r, t_f$	0.6/0.5	$\mu s$
Capacitance ( $V_R = 0$ V, $f = 1$ MHz)	$C_0$	25	pF
Forward Voltage ( $I_F = 100$ mA, $t_{pulse} = 20$ ms)	$V_F$	1.5 (≤ 1.8)	V
( $I_F = 1$ A, $t_{pulse} = 100 \mu s$ )	$V_F$	3.0 (≤ 3.8)	V
Breakdown voltage ( $I_R = 10 \mu A$ )	$V_{BR}$	30 (≥ 5)	V
Reverse current ( $V_R = 5$ V)	$I_R$	0.01 (≤ 1)	$\mu A$
Temperature coefficient of $I_e$ or $\Phi_e$	TC	-0.5	%/K
Temperature coefficient of $V_F$	TC	-0.2	%/K
Temperature coefficient of $\lambda_{peak}$	TC	0.25	nm/K

**Radiant Intensity  $I_e$  in Axial Direction Measured at a Solid Angle of  $\Omega = 0.01sr$**

Group	SFH 487P-1	SFH 487P-2	
Radiant Intensity $I_e$ ( $I_F = 100$ mA, $T_p = 20$ ms)	2-4	≥ 3.15	mW/sr
( $I_F = 1$ A, $T_p = 100 \mu s$ )	25	35	mW/sr
Total Radiant Flux $\Phi_e$ ( $I_F = 100$ mA, $T_p = 20$ ms)	21	23	mW

T-413

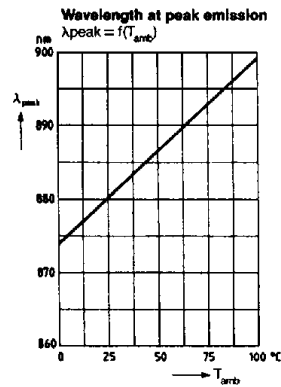
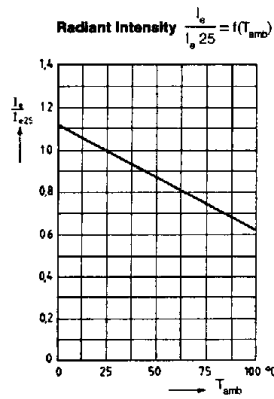
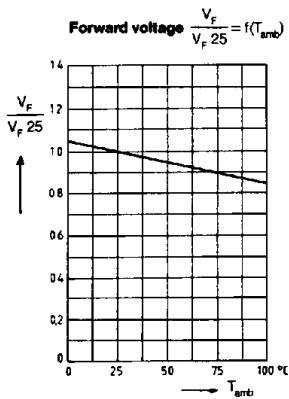
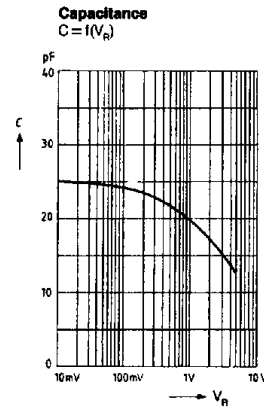
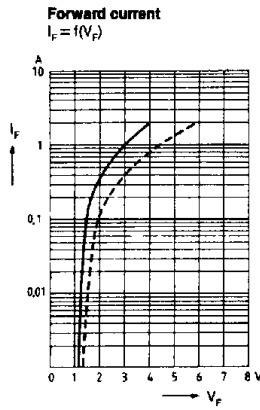
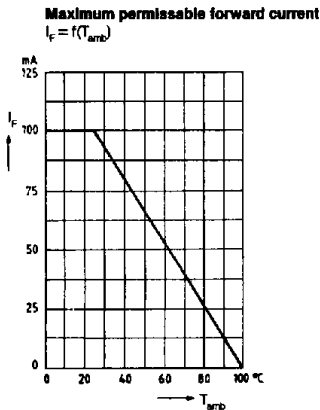
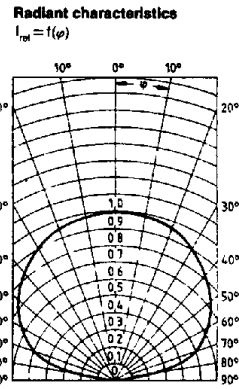
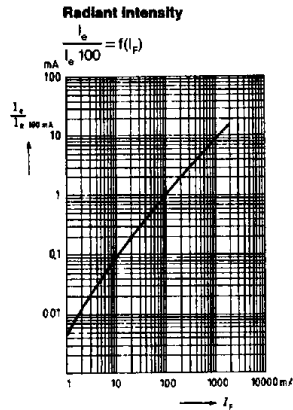
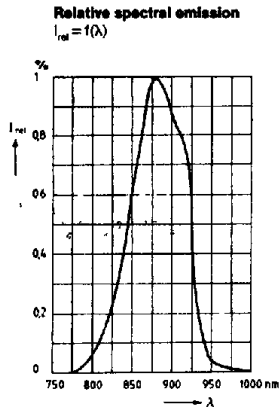

**Permissible Pulse Load**  
 $I_F = f(t)$   
 Duty cycle D = Parameter

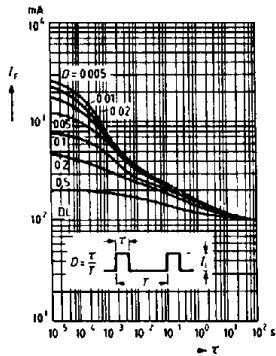

**Forward current (max):**  
 dependent upon the lead length  
 from the package bottom to the  
 PC board.

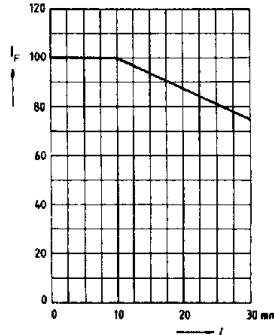

Infrared  
Emitters