

0.3" Dual Digit Numeric LED Displays

LTD-322 Series

LTD-323

Features

- 0.3 inch (7.62mm) digit height
- Continuous uniform segments.
- Choices of five bright colors-**AlGaAs red/bright red/ green/yellow/red orange.**
- Low power requirement.
- Excellent characters appearance.
- High contrast.
- High brightness.
- Wide viewing angle.
- Solid state reliability.
- Common anode or Common cathode modes.
- Two digit package simplifies alignments & assembly.
- Leads on 0.1" (2.54mm) centers.
- Categorized for luminous intensity.
- I.C. compatible.
- Easy mounting on P.C. board.

Package Dimensions

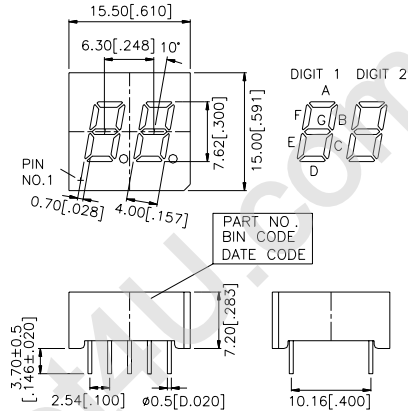

Notes: All dimensions are in millimeters (inches).

Tolerance: $\pm 0.25\text{mm}$ (0.01") unless otherwise noted.

Description

The LTD-322/323 series are 0.3 inch (7.62mm) height dual digit displays. All device displays have black face and white segments.

The AlGaAs red seven segment displays are designed for applications requiring low power consumption. They are tested and selected for the excellent low current characteristics to ensure that the segments are matched at low current. Drive current as low as 1 mA per segment is available.

The AlGaAs red series device utilize LED chips which are made from AlGaAs on a non-transparent GaAs substrate. The bright red and green series devices utilize LED chips which are made from GaP on a transparent GaP substrate. The yellow, red orange series devices utilize LED chips which are made from GaAsP on a transparent GaP substrate.

Devices

Part No. LTD-					Description	Internal Circuit Diagram
AlGaAs Red	Bright Red	Green	Yellow	Red Orange		
322WC	322P	322G	322Y	322E	Dualplex Common Cathode, Rt. Hand Decimal	A
323WC	323P	323G	323Y	323E	Dualplex Common Anode, Rt. Hand Decimal	B

Pin Connection

Pin No.	Connection	
	A.LTD-322	B.LTD-323
1.	Anode G	Cathode G
2.	No Pin	No Pin
3.	Anode A	Cathode A
4.	Anode F	Cathode F
5.	Common Cathode (Digit 2)	Common Anode (Digit 2)
6.	Anode D	Cathode D
7.	Anode E	Cathode E
8.	Anode C	Cathode C
9.	Anode B	Cathode B
10.	Common Cathode (Digit 1)	Common Anode (Digit 1)

Internal Circuit Diagrams

A.LTD-322

B.LTD-323

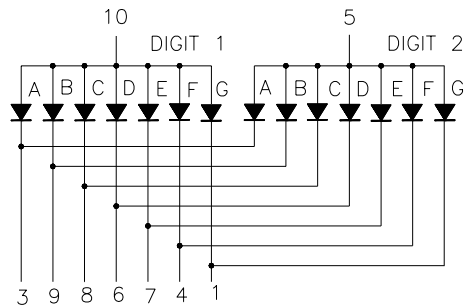
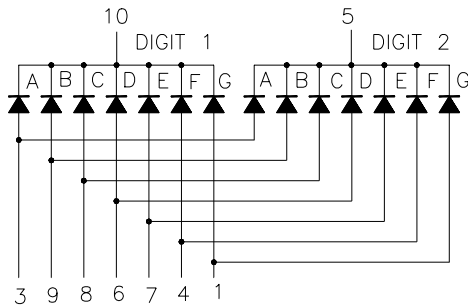

Absolute Maximum Rating at Ta=25°C

Parameter	AlGaAs Red	Bright Red	Green	Yellow	Red Orange	Unit
Power Dissipation Per Segment	75	40	75	60	75	mW
Peak Forward Current Per Segment (1/10 Duty Cycle, 0.1ms Pulse Width)	125	60	100	80	100	mA
Continuous Forward Current Per Segment Derating Linear from 25°C Per Segment	30 0.4	15 0.2	25 0.33	20 0.27	25 0.33	mA mA/°C
Reverse Voltage Per Segment	5	5	5	5	5	V
Operating Temperature Range	-35°C to +85°C					
Storage Temperature Range	-35°C to +85°C					
Solder Temperature 1/16 Inch Below Seating Plane for 3 Seconds at 260°C						

Electrical/Optical Characteristics at Ta=25°C

LTD-322WC/323WC

Parameter	Symbol	Min.	Typ.	Max.	Unit	Tset Condition
Average Luminous Intensity	I _v	200	600		μ cd	I _F =1mA
			3100			I _F =5mA
Peak Emission Wavelength	λ _P		660		nm	I _F =20mA
Spectral Line Half-Width	Δλ		35		nm	I _F =20mA
Dominant Wavelength	λ _d		638		nm	I _F =20mA
Forward Voltage, Per Segment	V _F		1.6	2.4	V	I _F =1mA
			1.7			I _F =5mA
			1.8			I _F =20mA
Reverse Current, Per Segment	I _R			100	μ A	V _R =5V
Luminous Intensity Matching Ratio	I _{v-m}			2:1		I _F =10mA

LTD-322P/323P

Parameter	Symbol	Min.	Typ.	Max.	Unit	Tset Condition
Average Luminous Intensity	I _v	210	650		μ cd	I _F =10mA
Peak Emission Wavelength	λ _P		697		nm	I _F =20mA
Spectral Line Half-Width	Δλ		90		nm	I _F =20mA
Dominant Wavelength	λ _d		657		nm	I _F =20mA
Forward Voltage, Per Segment	V _F		2.1	2.6	V	I _F =20mA
Reverse Current, Per Segment	I _R			100	μ A	V _R =5V
Luminous Intensity Matching Ratio	I _{v-m}			2:1		I _F =10mA

LTD-322G/323G

Parameter	Symbol	Min.	Typ.	Max.	Unit	Tset Condition
Average Luminous Intensity	I_v	540	1600		μ cd	$I_F=10\text{mA}$
Peak Emission Wavelength	λ_P		565		nm	$I_F=20\text{mA}$
Spectral Line Half-Width	$\Delta\lambda$		30		nm	$I_F=20\text{mA}$
Dominant Wavelength	λ_d		569		nm	$I_F=20\text{mA}$
Forward Voltage, Per Segment	V_F		2.1	2.6	V	$I_F=20\text{mA}$
Reverse Current, Per Segment	I_R			100	μ A	$V_R=5\text{V}$
Luminous Intensity Matching Ratio	$I_v\text{-m}$			2:1		$I_F=10\text{mA}$

LTD-322Y/323Y

Parameter	Symbol	Min.	Typ.	Max.	Unit	Tset Condition
Average Luminous Intensity	I_v	500	2000		μ cd	$I_F=10\text{mA}$
Peak Emission Wavelength	λ_P		585		nm	$I_F=20\text{mA}$
Spectral Line Half-Width	$\Delta\lambda$		35		nm	$I_F=20\text{mA}$
Dominant Wavelength	λ_d		588		nm	$I_F=20\text{mA}$
Forward Voltage, Per Segment	V_F		2.1	2.6	V	$I_F=20\text{mA}$
Reverse Current, Per Segment	I_R			100	μ A	$V_R=5\text{V}$
Luminous Intensity Matching Ratio	$I_v\text{-m}$			2:1		$I_F=10\text{mA}$

LTD-322E/323E

Parameter	Symbol	Min.	Typ.	Max.	Unit	Tset Condition
Average Luminous Intensity	I_v	500	2000		μ cd	$I_F=10\text{mA}$
Peak Emission Wavelength	λ_P		630		nm	$I_F=20\text{mA}$
Spectral Line Half-Width	$\Delta\lambda$		40		nm	$I_F=20\text{mA}$
Dominant Wavelength	λ_d		621		nm	$I_F=20\text{mA}$
Forward Voltage, Per Segment	V_F		2.0	2.6	V	$I_F=20\text{mA}$
Reverse Current, Per Segment	I_R			100	μ A	$V_R=5\text{V}$
Luminous Intensity Matching Ratio	$I_v\text{-m}$			2:1		$I_F=10\text{mA}$

Note: Luminous intensity is measured with a light sensor and filter combination that approximates the CIE (Commission Internationale De L'Eclairage) eye-response curve.

Typical Electrical/Optical Characteristic Curves (25°C Ambient Temperature Unless Otherwise Noted)

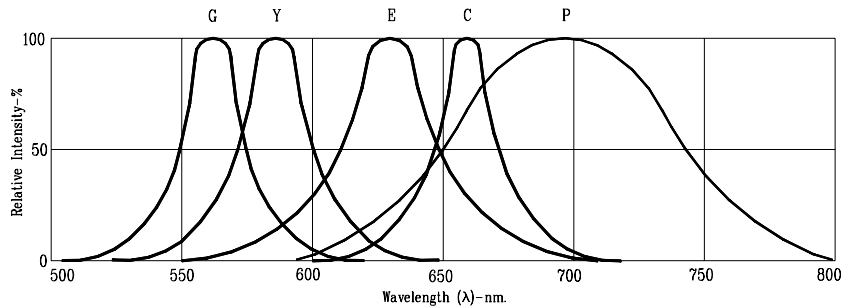

Fig1. RELATIVE INTENSITY VS. WAVELENGTH

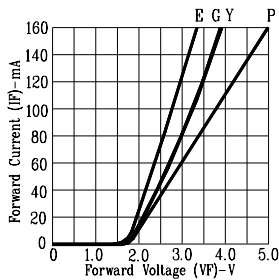

Fig2. FORWARD CURRENT VS. FORWARD VOLTAGE

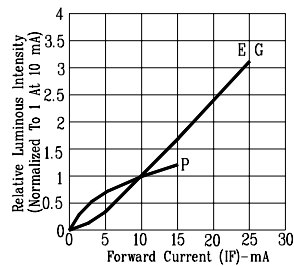

Fig3. RELATIVE LUMINOUS INTENSITY VS. FORWARD CURRENT

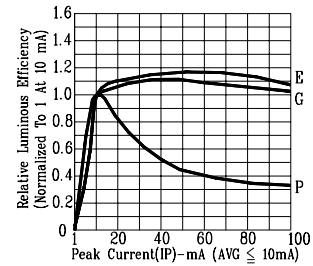

Fig4. RELATIVE LUMINOUS EFFICIENCY (LUMINOUS INTENSITY PER UNIT CURRENT) VS. PEAK CURRENT

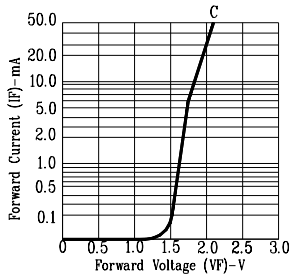

Fig5. FORWARD CURRENT VS. FORWARD VOLTAGE

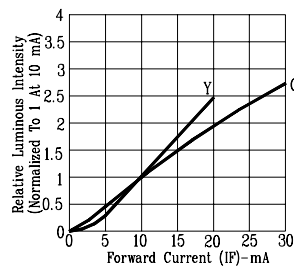

Fig6. RELATIVE LUMINOUS INTENSITY VS. FORWARD CURRENT

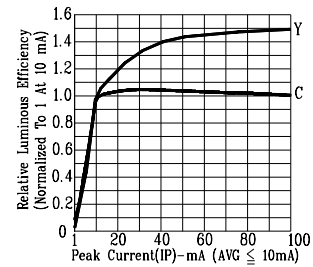

Fig7. RELATIVE LUMINOUS EFFICIENCY (LUMINOUS INTENSITY PER UNIT CURRENT) VS. PEAK CURRENT

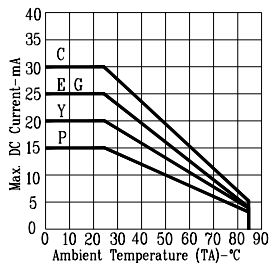

Fig8. MAX. ALLOWABLE DC CURRENT VS. AMBIENT TEMPERATURE.

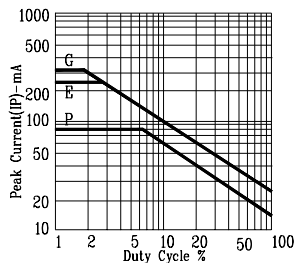

Fig9. MAX. PEAK CURRENT VS. DUTY CYCLE % (REFRESH RATE 1KHz)

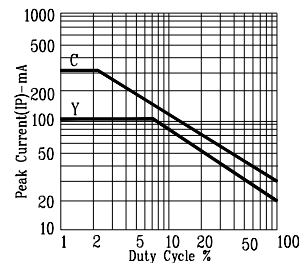

Fig10. MAX. PEAK CURRENT VS. DUTY CYCLE % (REFRESH RATE 1KHz)

NOTE: C=AlGaAs RED P=BRIGHT RED G=GREEN E=RED ORANGE Y=YELLOW (REFRESH RATE 1KHz)